

# INSTALLATION INSTRUCTIONS

**SERIES DH-350**

## **IMPACT RESISTANT DOOR** **MEDIUM STILE ENTRANCE DOORS**



---

Phone: (800) 421-6144 • Fax: (800) 582-7501  
crlaurence.com • usalum.com • crl-arch.com

---

11M0187

## HANDLING, STORAGE, AND PROTECTION OF ALUMINUM

The following precautions are recommended to protect the material against damage. Following these precautions will help ensure early acceptance of your products and workmanship.

**A. HANDLE CAREFULLY.**

All aluminum materials at job site must be stored in a safe place, well removed from possible damage by other trades. Cardboard wrapped or paper interleaved materials must be kept dry.

**B. CHECK ARRIVING MATERIALS.**

Check for quantities and keep records of where various materials are stored.

**C. KEEP MATERIALS AWAY FROM WATER, MUD, AND SPRAY.**

Prevent cement plaster or other materials from damaging the finish.

**D. PROTECT THE MATERIALS AFTER ERECTION.**

Protect erected frame with polyethylene or canvas splatter screen. Cement, plaster, terrazzo, other alkaline solutions, and acid based materials used to clean masonry are harmful to the finish. If any of these materials come in contact with the aluminum, immediately remove with water and mild soap.

**IMPORTANT: READ THIS MANUAL THOROUGHLY BEFORE BEGINNING INSTALLATION.**

## ORDER OF ASSEMBLY AND INSTALLATION

|                               |        |
|-------------------------------|--------|
| INTRODUCTION .....            | 4      |
| PARTS LIST .....              | 4      |
| GLASS SPECIFICATIONS .....    | 5      |
| DOOR GLAZING .....            | 5 - 6  |
| DOOR FRAME INSTALLATION ..... | 7 - 10 |
| OPTIONAL TRANSOM .....        | 11     |
| GUIDE TO SEALANTS .....       | 12     |
| JOB SITE ESSENTIALS .....     | 13     |

# GENERAL INSTALLATION NOTES

## Recommended Guidelines For All Installations:

- 1. REVIEW CONTRACT DOCUMENTS.** Check shop drawings, installation instructions, architectural drawings, and shipping lists to become thoroughly familiar with the project. The shop drawings take precedence and include specific details for the project. Note any *field verified* notes on the shop drawings prior to installing. The installation instructions are of a general nature and cover most conditions.
- 2. INSTALLATION.** All materials are to be installed plumb, level, and true. Install operable windows preglazed only.
- 3. BENCH MARKS.** All work should start from bench marks and/or column lines as established by the architectural drawings and the general contractor with guaranteed accuracy. Working from these datum points and lines determine:
  - a) The plane of the wall in reference to offset lines provided on each floor.
  - b) The finish floor lines in reference to bench marks on the outer building columns.
  - c) Mullion spacing from both ends of masonry opening to prevent dimensional build-up of daylight opening.
- 4. FIELD WELDING.** All field welding must be adequately shielded to avoid any splatter on glass or aluminum. Results will be unsightly and/or structurally unsound. Advise general contractor and other trades accordingly. All field welds of steel anchors must receive touch-up paint (zinc chromate) to avoid rust.
- 5. SURROUNDING CONDITIONS.** Make certain that construction which will receive your materials is in accordance with the contract documents. If not, notify the general contractor in writing and resolve differences before proceeding with work.
- 6. ISOLATION OF ALUMINUM.** Aluminum to be placed in direct contact with uncured masonry or incompatible materials should be isolated with a heavy coat of zinc chromate or bituminous paint.
- 7. SEALANTS.** Sealants must be compatible with all materials with which they have contact, including other sealant surfaces. Consult with sealant manufacturer for recommendations relative to joint size, shelf life, compatibility, cleaning, priming, tooling, adhesion, etc. It is the responsibility of the **Glazing Contractor** to submit a statement from the sealant manufacturer indicating that glass and glazing materials have been tested for compatibility and adhesion with glazing sealants, and interpreting test results relative to material performance, including recommendations for primers and substrate preparation required to obtain adhesion. The chemical compatibility of all glazing materials and framing sealants with each other and with like materials used in glass fabrication must be established. This is required on every project.
- 8. FASTENING.** Within the body of these instructions "fastening" means any method of securing one part to another or to adjacent materials. Only those fasteners used within the system are specified in these instructions. Due to the varying perimeter conditions and performance requirements, perimeter and anchor fasteners are not specified in these instructions. For perimeter and anchor fasteners refer to the shop drawings or consult the fastener supplier.
- 9. BUILDING CODES.** Due to the diversity in state/provincial local, and federal laws and codes that govern the design and application of architectural products, it is the responsibility of the individual architect, owner, and installer to assure that products selected for use on projects comply with all the applicable building codes and laws. U.S. Aluminum exercises no control over the use or application of its products, glazing materials, and operating hardware, and assumes no responsibility thereof.
- 10. EXPANSION JOINTS.** Expansion joints and perimeter seals shown in these instructions and in the shop drawings are shown at normal size. Actual dimensions may vary due to perimeter conditions and/or difference in metal temperature between the time of fabrication and the time of installation. Gaps between expansion members should be based on temperature at time of installation.
- 11. WATER HOSE TEST.** As soon as a representative amount of the wall has been glazed (500 square feet or 46.5 m<sup>2</sup>) a water hose test should be conducted in accordance with AAMA 501.2 specifications to check the installation. On all jobs the hose test should be repeated every 500 square feet (46.5 m<sup>2</sup>) during the glazing operation.
- 12. COORDINATION WITH OTHER TRADES.** Coordinate with the general contractor any sequence with other trades which offset curtain wall installation (i.e. fire proofing, back-up walls, partitions, ceilings, mechanical ducts, converters, etc.)
- 13. CARE AND MAINTENANCE.** Final cleaning of exposed aluminum surfaces should be done in accordance with AAMA 609.1 for anodized aluminum and 610.1 for painted aluminum.

# INTRODUCTION

The DH-350 is a High Performance Hurricane Resistant Storefront Entrance Door designed for all commercial entrance applications including retail space, hotels, condominiums, office buildings, institutional facilities, and industrial structures. The DH-350 complies with the stringent requirements of Florida's Miami-Dade County Building Codes, making it the top choice for installation in areas ravished by hurricanes. The DH-350 is intended to be installed in punched openings or as a liner frame within other U.S. Aluminum Impact Framing Systems.

# SERIES LIST

Cat. No. DH350A10D0L

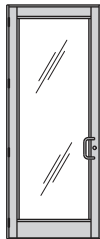

Series DH350A10 Hurricane Impact Medium Stile Single Door 36" x 84" (914 x 2137 mm)

Cat. No. DH350A10FNL

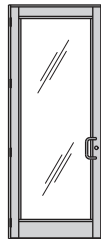

DHS350A10 Up and Over Frame for 36" x 84" (914 x 2137 mm) Door

Cat. No. DH350A10FTL



DHS350A10 Transom Frame for Single 36" x 84" x 120" (914 x 2137 mm) Door

Cat. No. DH350A10D0P

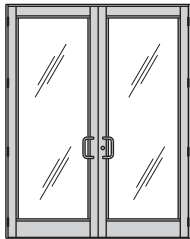

Series DH350A10 Hurricane Impact Medium Stile Pair Doors 72" x 84" (1829 x 2317 mm)

Cat. No. DH350A10FNP

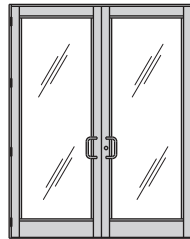

Series DH350A10 Up and Over Frame for Pair 72" x 84" (1829 x 2317 mm) Door

Cat. No. DH350A10FTP

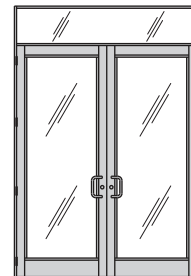

DHS350A10 Transom Frame for Pair 72" x 84" (1829 x 2317 mm) Door

## DH-350 IMPACT RESISTANT DOORS

The DH-350 Impact Resistant Entrance Door must be properly installed in order to maintain the safety characteristics engineered into each system. The door frame must be installed square in the opening and the door must be square inside the door frame. Failure to do so may prevent proper closing of the door and engagement of the four point locking system.

This unit is shipped with the door pre-hung in the door frame and must be removed prior to installation. The door should also be removed for all glazing procedures.

## GLASS SPECIFICATIONS

Make sure the glass meets the following specifications:

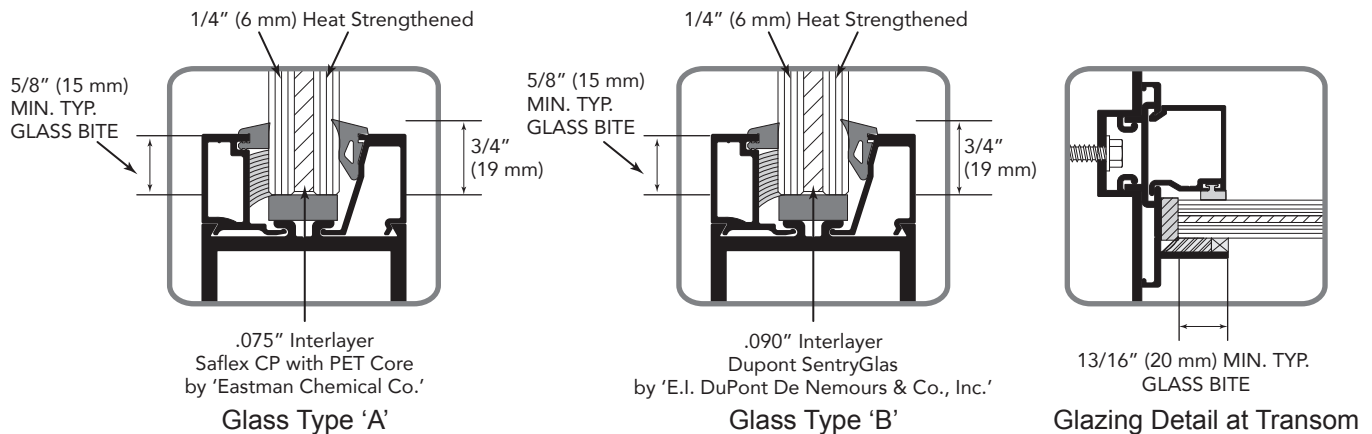

## DOOR GLAZING

THIS IS AN "IMPACT RESISTANT" DOOR. BENCH GLAZE THIS DOOR PRIOR TO INSTALLATION.

Clean both sides of the glass using the 2-wipe method detailed below.

**2-Wipe Method:** Use two clean, lint free rags. Apply alcohol or approved cleaner to one rag. Wipe area where silicone is to be applied thoroughly, removing all oils and dust or dirt. Using the second dry rag, wipe the same area thoroughly.

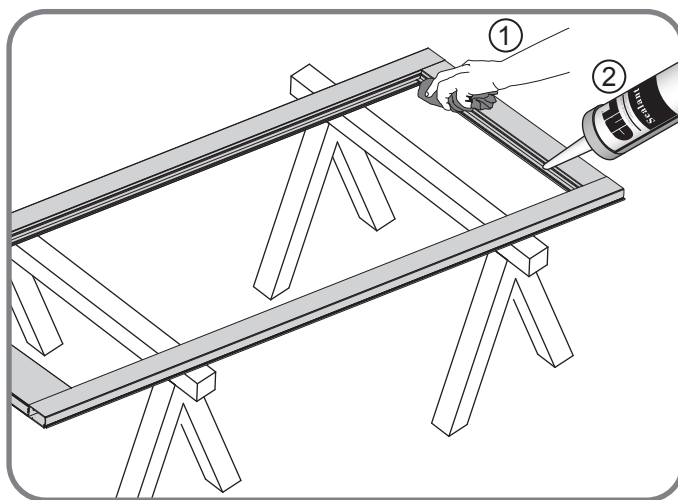

1. Clean non-removable glass stop using the 2-wipe method.

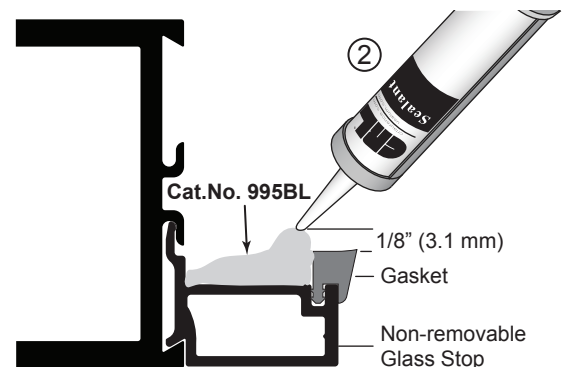

2. Fill the area between the gasket and the non-removable glass stop to approximately 1/8" above the level of the gasket with CRL Cat. No. 995BL Dow 995 silicone.

## DOOR GLAZING (CONTINUED)

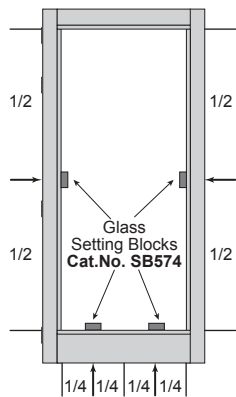

Install setting blocks at quarter points on bottom and at mid points on sides.

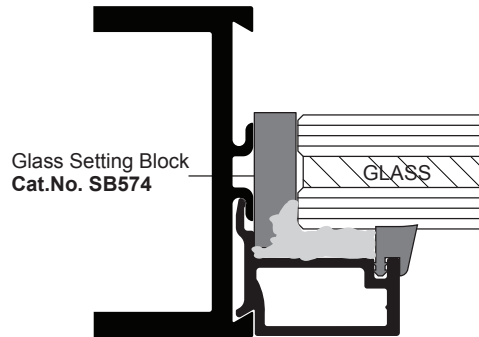

3. Clean the glass edges using the 2-wipe method and carefully install the glass into the frame.

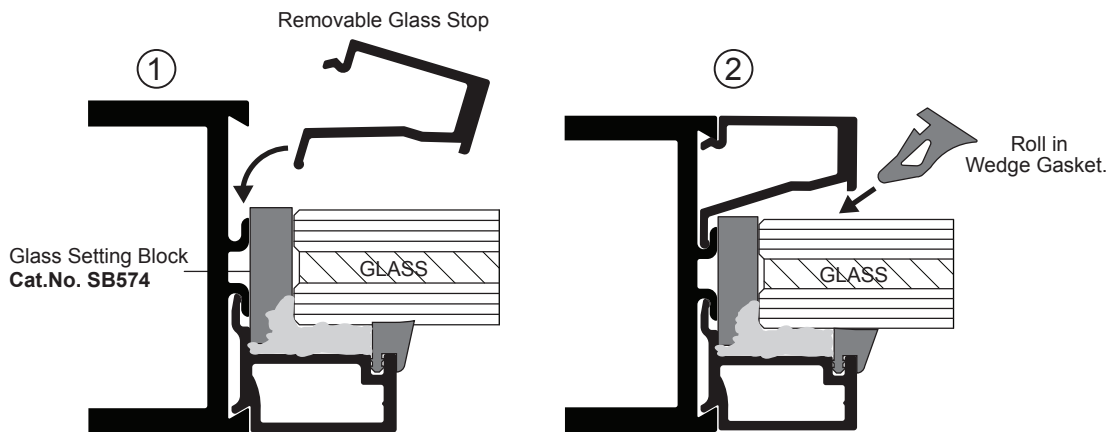

4. Install glass stop and roll in wedge gasket.

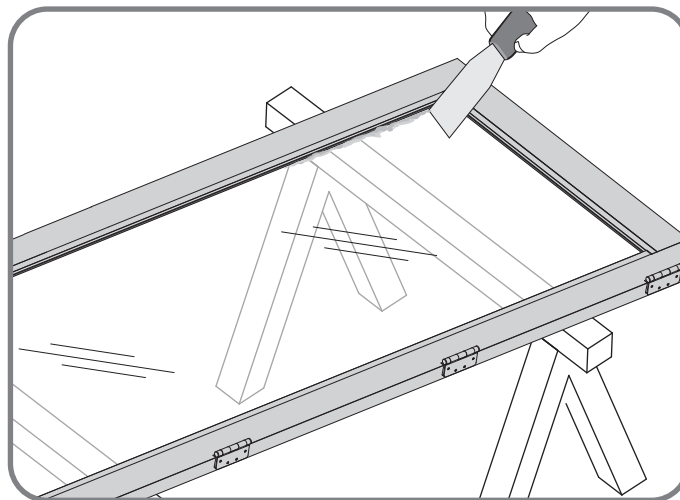

5. Flip the door and clean off excess silicone from glass edges using a putty knife.

NOTE: Cut horizontal gaskets to run through. Non-removable glass stops are factory installed.

## DOOR FRAME INSTALLATION

This is an “impact resistant” door and frame. Because of the thickness of both the aluminum and the glass, it is advisable that at least two individuals are involved in moving and installing this door. Install the frame without the door. NOTE: Installation instructions for the door closer are provided within the closer box.

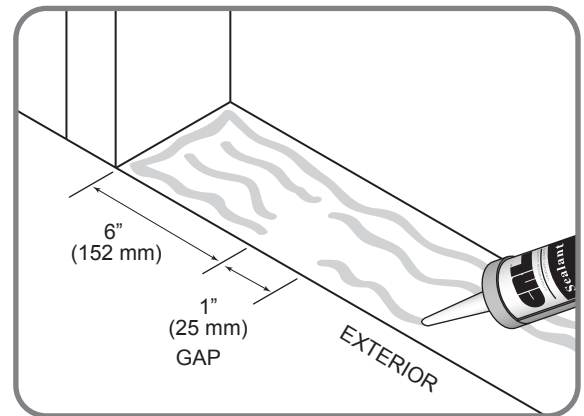
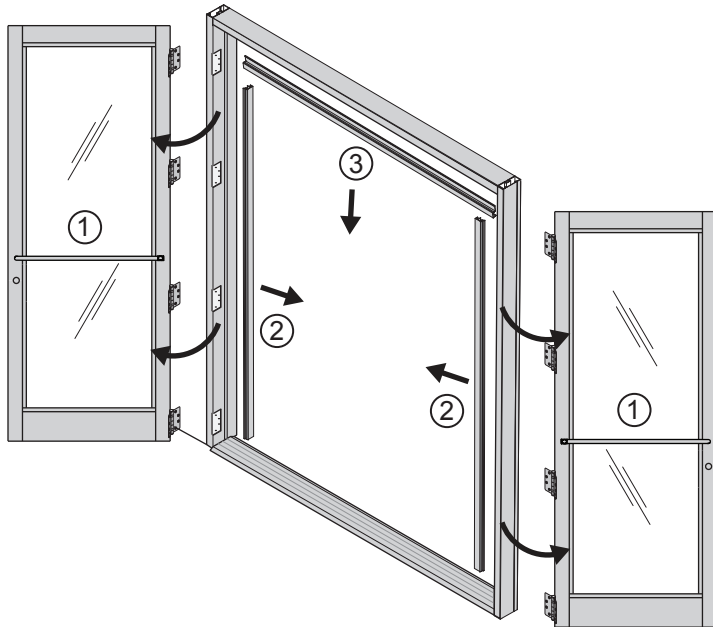

1. Remove doors and door stops from frame.

2. Prepare bed of CRL Cat. No. 33S sealant with 1" gaps on each side for drainage.

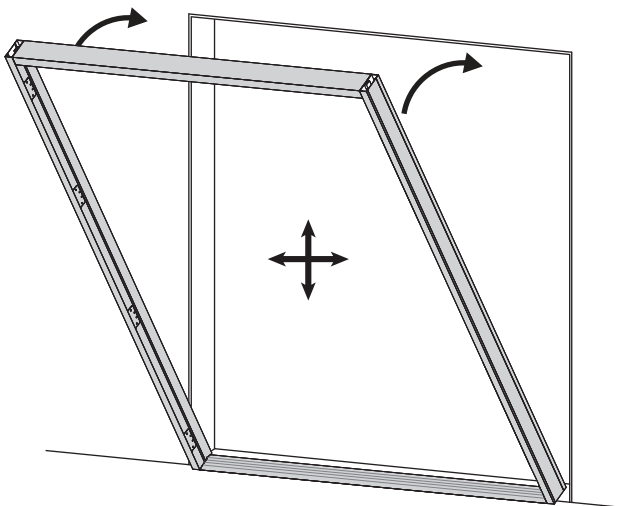

3. Place frame in center of opening. Attach at top and bottom jambs with anchors and shims. Refer to “Maximum Anchor Spacing” chart above. Level and square the frame. Then tighten completely.

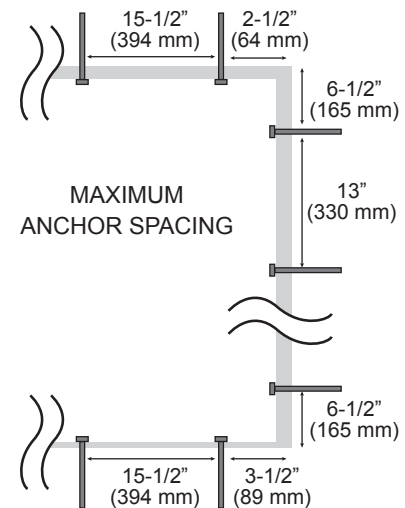

# DOOR FRAME INSTALLATION (CONTINUED)

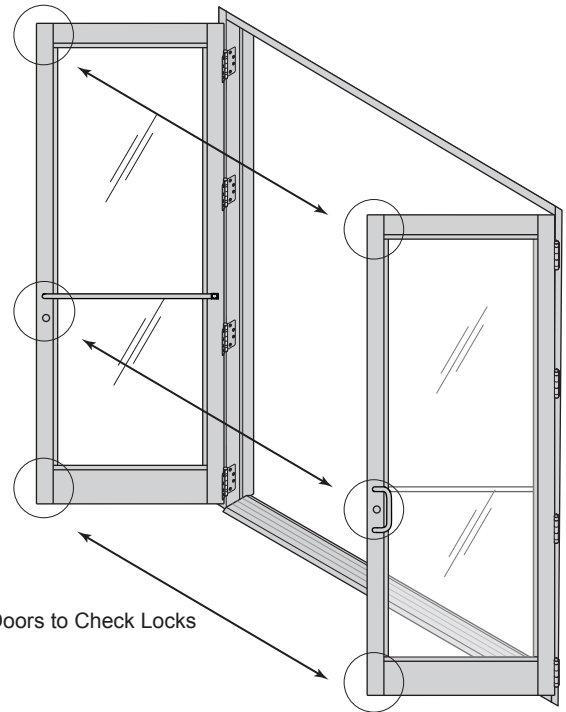
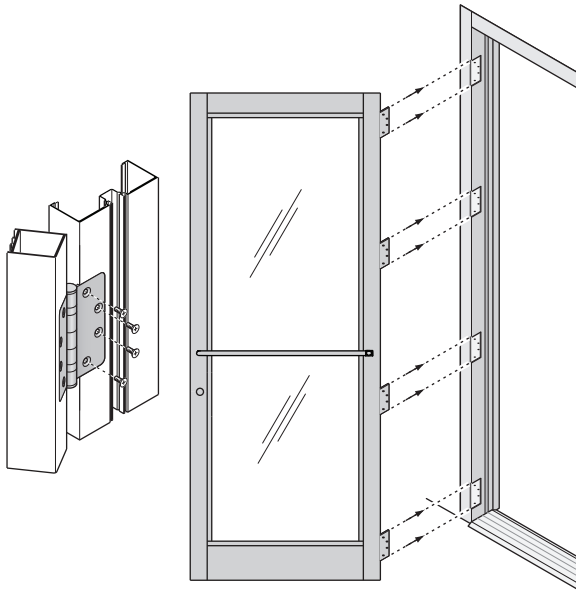

4. Hang the door. Check alignment of the door with the frame. Adjust as needed.

5. Open the doors to test the locking mechanism.

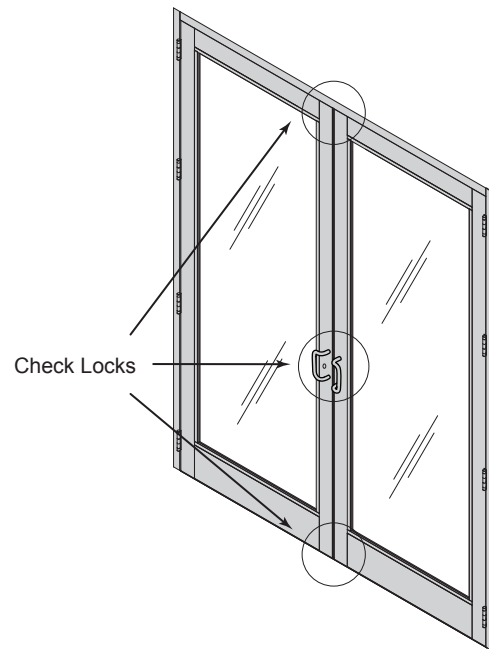
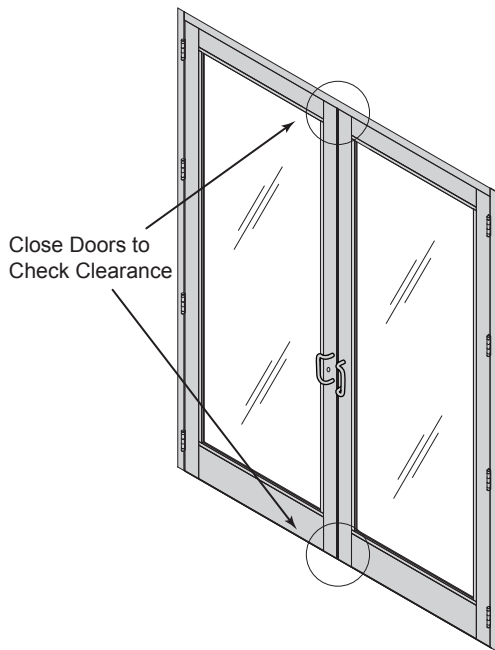

6. Close the doors and engage locks and check clearance. Adjust as needed to plumb and level.

7. Close doors and check locks again. Adjust as necessary to plumb and level.



# DOOR FRAME INSTALLATION (CONTINUED)

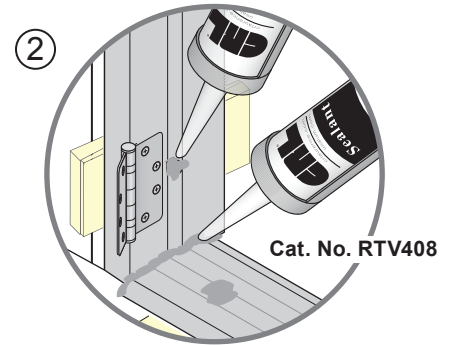
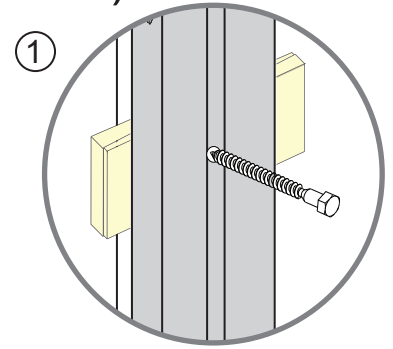
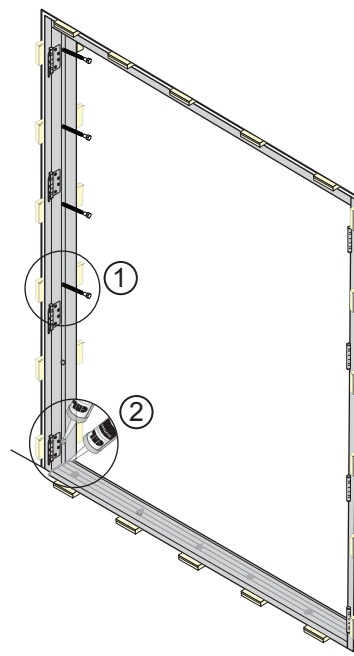
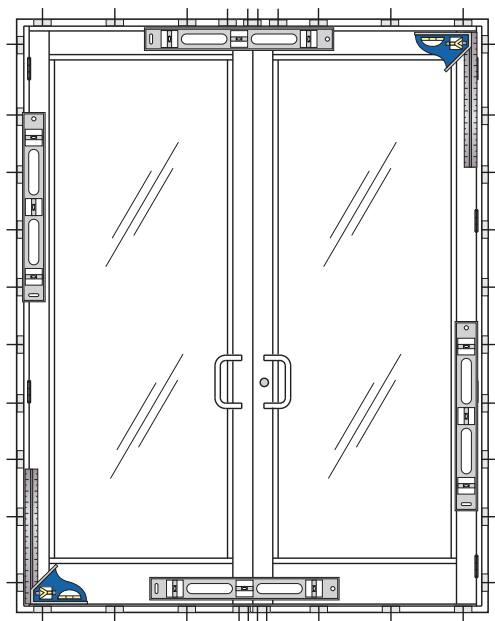

8. Ensure door and frame are level and plumb. Install shims, open doors and follow maximum anchor spacing shown on page 7 to secure frame. Use **Cat. No. RTV408** to seal corners and over screw heads.

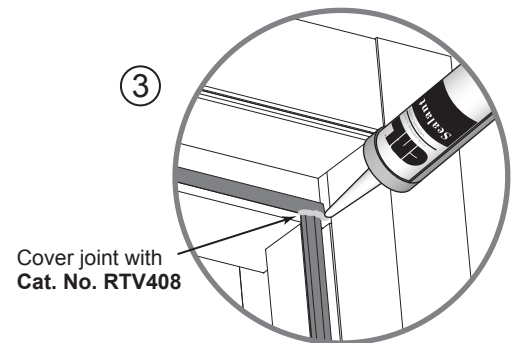
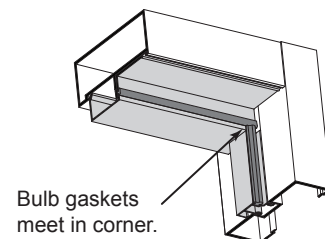
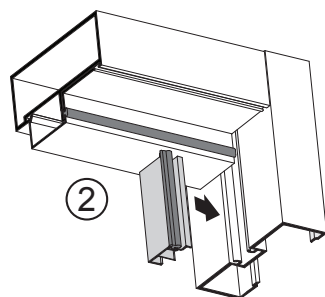
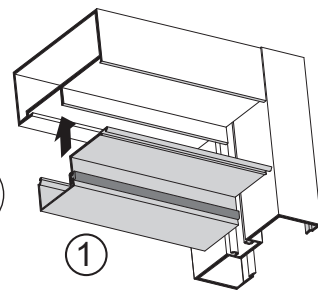
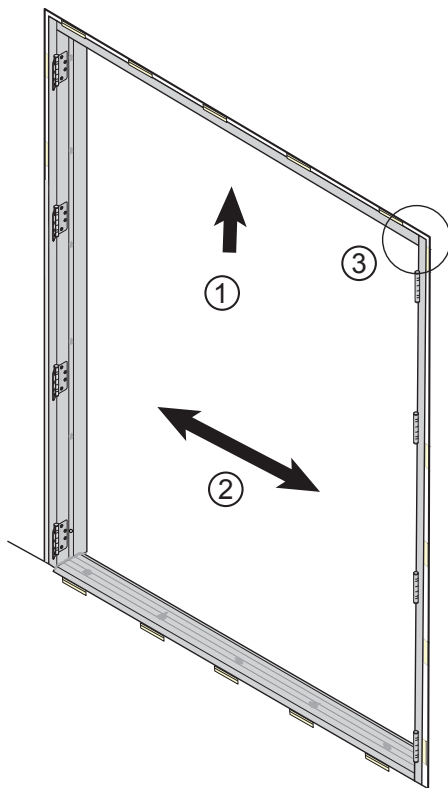

9. Install door stops at head and jambs. Trim the bulb gasket on the vertical door stops so they mate with the horizontal bulb gaskets.

10. Apply CRL **Cat. No. RTV408** sealant at junction of vertical and horizontal bulb gaskets.

# DOOR FRAME INSTALLATION (CONTINUED)

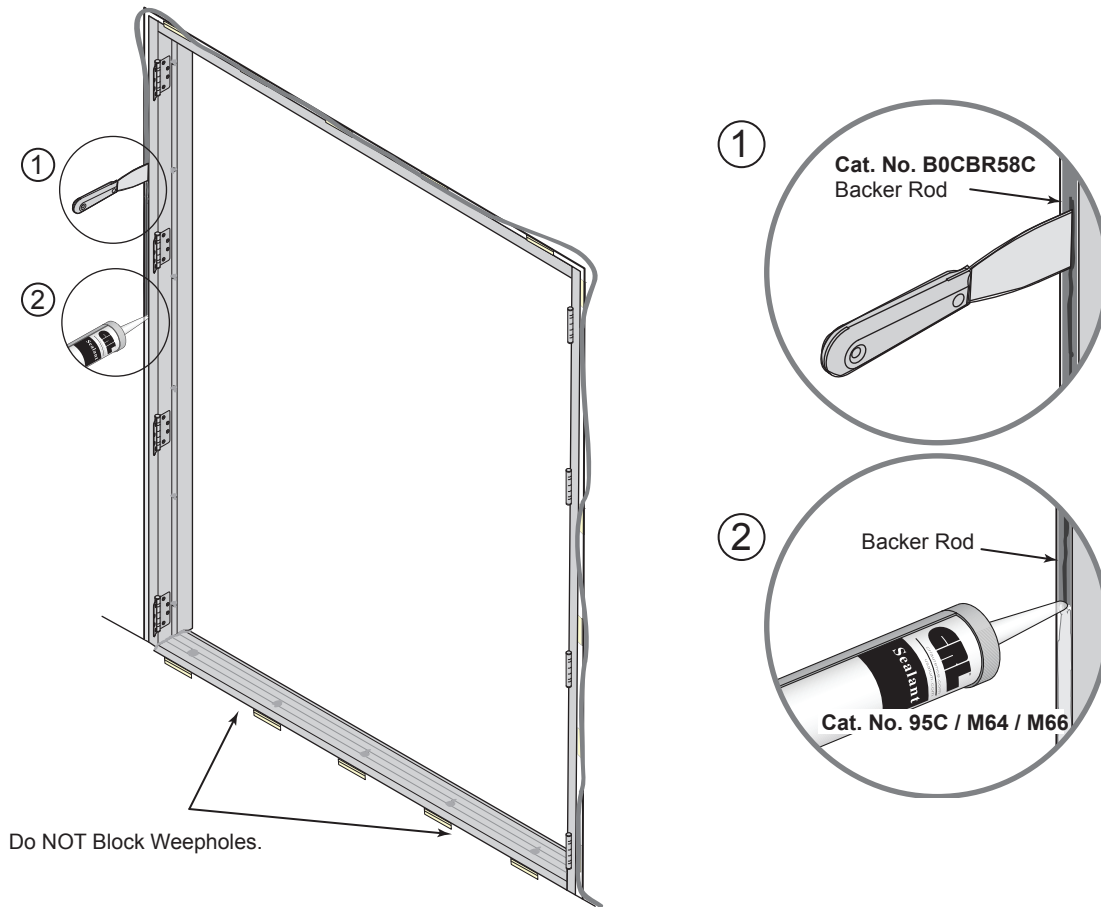

11. Insert Cat. No. B0CBR58C backer rod between frame and opening. Seal interior and exterior perimeters with CRL Cat. No. 95C / M64 / M66 (See Sealant Guide on page 12).

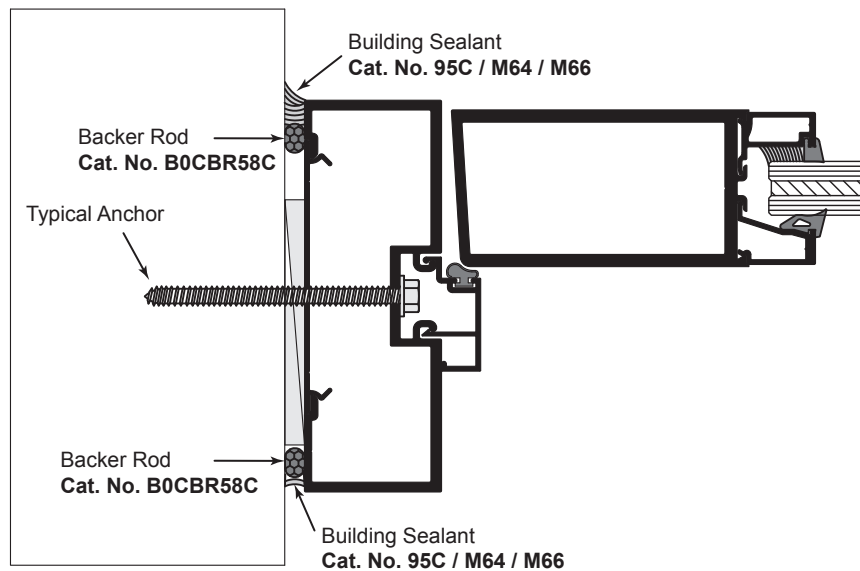

# OPTIONAL TRANSOM

## TYPICAL ANCHORS

1/4" DIAMETER ULTRACON BY 'ELCO' (FU = 177, FY = 155 KSI)  
 INTO 2BY WOOD BUCKS OR WOOD STRUCTURES  
 1-1/2" MINIMUM PENETRATION INTO WOOD

THRU 1BY BUCKS INTO CONCRETE OR MASONRY  
 1-1/4" MINIMUM EMBED INTO CONCRETE OR MASONRY

DIRECTLY INTO CONCRETE OR MASONRY  
 1-3/8" MINIMUM EMBED INTO CONCRETE  
 1-1/4" MINIMUM EMBED INTO MASONRY

#14 SMS OR SELF DRILLING SCREWS (GRADE 2 CRS)  
 INTO METAL STRUCTURES  
 STEEL : 12 GA. MINIMUM (FY = 36 KSI MIN.)  
 ALUMINUM : 1/8" THICK MINIMUM (6063-T5 MIN.)  
 (STEEL IN CONTACT WITH ALUMINUM TO BE PLATED OR PAINTED)

## TYPICAL EDGE DISTANCE

INTO CONCRETE AND MASONRY = 2-1/2" MINIMUM  
 INTO WOOD STRUCTURE = 1" MINIMUM  
 INTO METAL STRUCTURE = 3/4" MINIMUM  
 CONCRETE AT HEAD, SILL OR JAMBS F'C = 3000 PSI  
 MINIMUM  
 C-90 HOLLOW/FILLED BLOCK AT JAMBS F'M = 2000 PSI  
 MINIMUM

## SEALANTS

FRAME CORNERS, ASSEMBLY SCREWS AND HEADS OF  
 ANCHOR SCREWS AT SILL TO BE SEALED WITH SEALER.  
 LEAF JOINTS SEALED WITH SILICONE CRL RTV408.  
 STRUCTURAL SEALANT TESTED WITH CRL 995W.

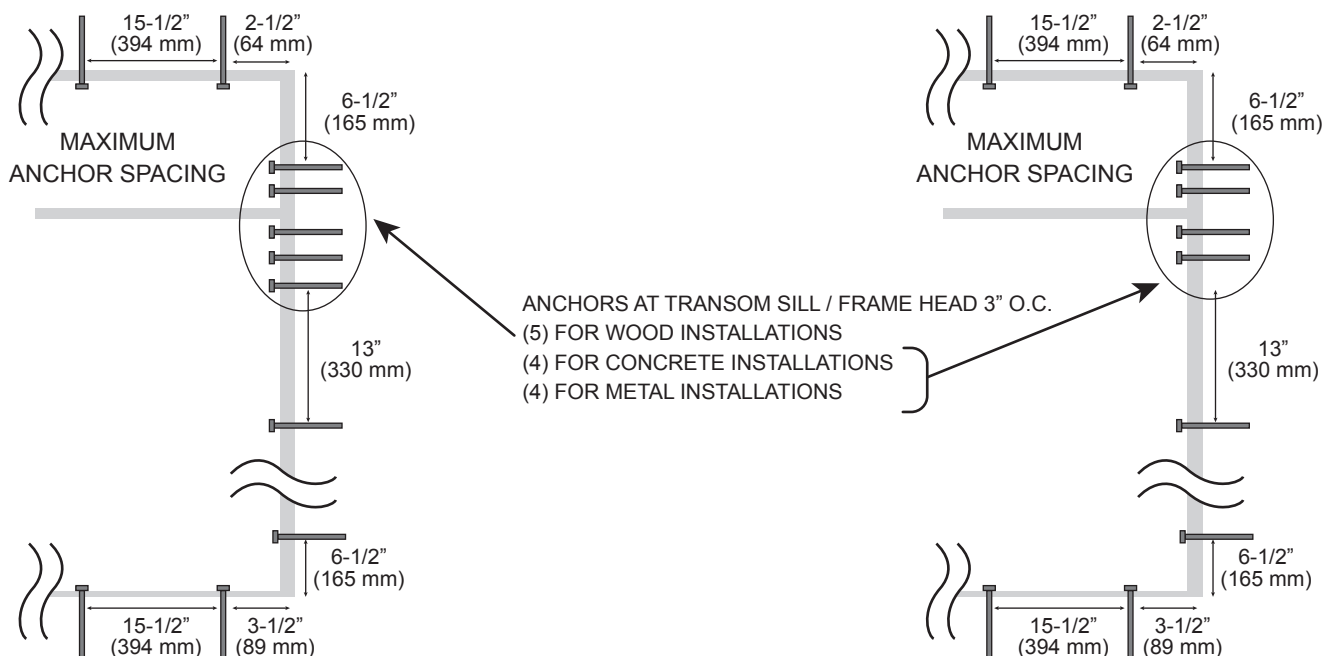
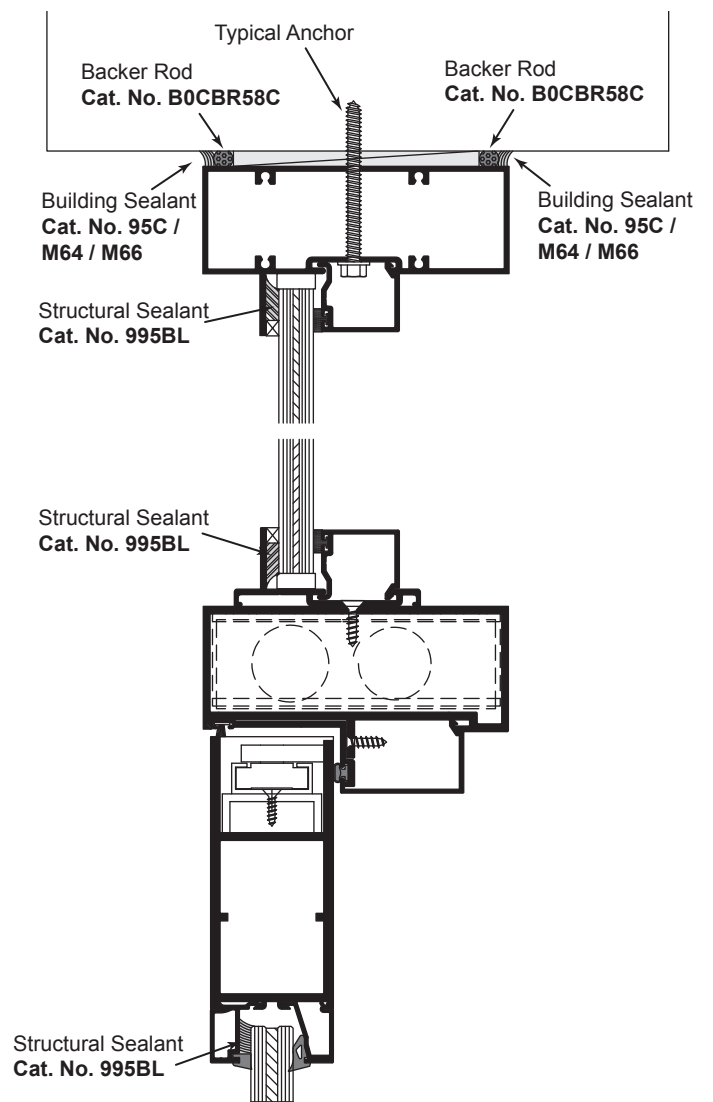



# GUIDE TO SEALANTS

**NOTE: All sealants must be tooled to ensure proper adhesion.**

## WATERPROOFING

- **33S ACETIC CURE SILICONE**

Sill to Subsill, End Dams, Screw Heads, and Threshold to Door Frame Sealing.

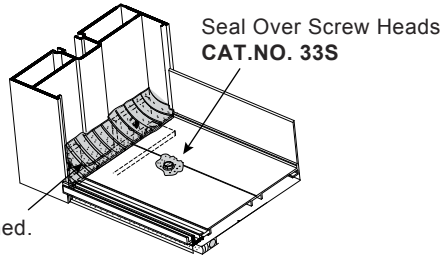

**NOTE: Not for use near insulating glass units with butyl sealant.**

## EXPANSION

- **95C NEUTRAL CURE SILICONE**

Expansion Joints.

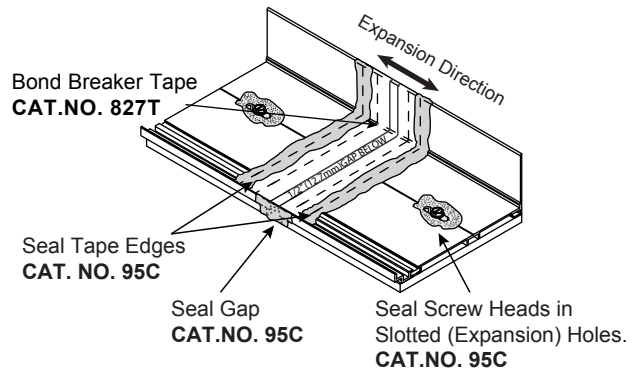

## JOINT ADHESIVE

- **RTV408 NEUTRAL CURE SILICONE**

Small Joints, End Joints and Buttered Surfaces, Water Diverters, End Dams and Reglet Fills.

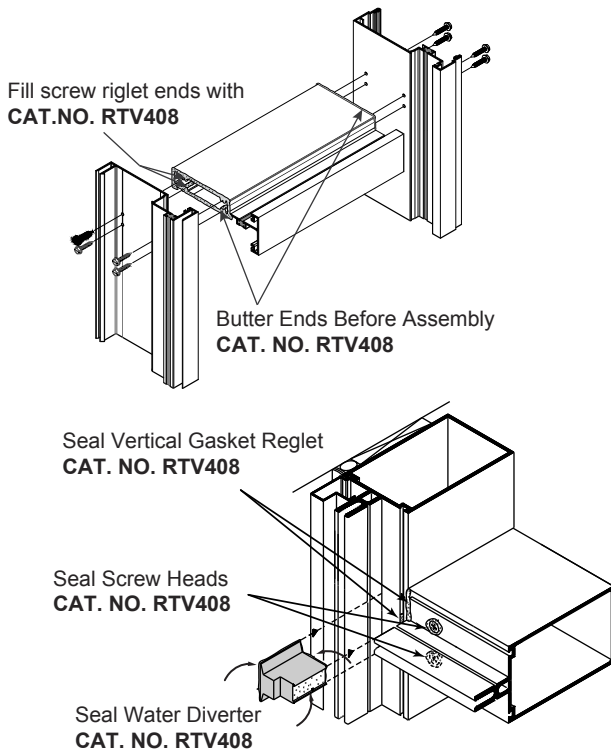

**NOTE: I.G. butyl contact OK.**

## PERIMETER

- **95C NEUTRAL CURE SILICONE (Preferred)**
- **M64 (SMOOTH) MODIFIED POLYURETHANE**
- **M66 (TEXTURED) MODIFIED POLYURETHANE**

Perimeter Seals, Expansion Joints, Sill and Threshold Beds, Concrete, Wood, and Steel Openings.

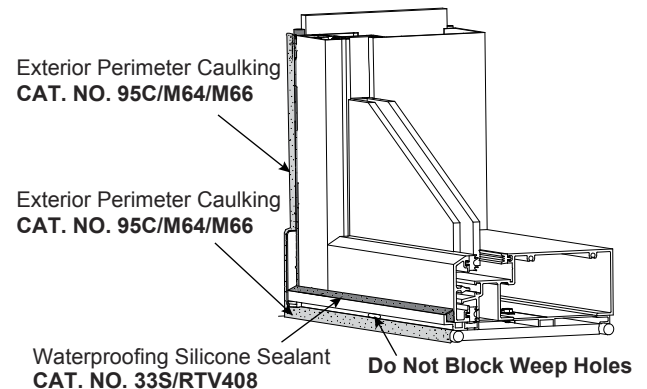

## STRUCTURAL

- **ALL STRUCTURAL SEALANTS REQUIRE TESTING AND APPROVAL.**

Glass-to-Glass or Glass-to-Metal



# JOB SITE ESSENTIALS

Helpful Tools and Supplies for Installing CRL U.S. Aluminum Entrances, Storefronts, Windows, and Curtain Wall Systems



**CRL Neutral Cure Silicone**  
CAT. NO. RTV408



**CRL Silicone Sealant**  
CAT. NO. 33S



**CRL Black Dow Corning® Silicone Structural Adhesive**  
CAT. NO. 995BL



**CRL Silicone Building Sealant**  
CAT. NO. 95C



**CRL Neoprene Setting Blocks**  
CAT. NO. SB574



**CRL Open Cell Backer Rod**  
CAT. NO. B0CBR58C



**CRL Backer Rod Roller Tool**  
CAT. NO. SBRR



**CRL Glass Cleaner**  
CAT. NO. 1973



**CRL Glass Wipes**  
CAT. NO. 1550

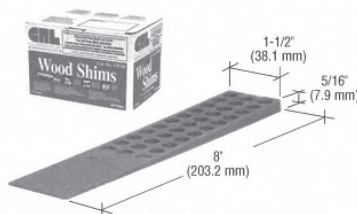

**CRL Wood Composite Shims**  
CAT. NO. BWCS8



**CRL Beddar Wood Shims™**  
CAT. NO. NWS12

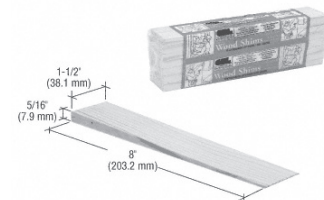

**CRL Wood Composite Shims**  
CAT. NO. NWS9