

INSTALLATION INSTRUCTIONS

ENTICE SERIES PREMIUM ENTRANCE SYSTEM EXTERIOR GLAZE



Phone: (800) 421-6144 • Fax: (800) 582-7501
crlaurence.com • usalum.com • crl-arch.com

11M0230_REV A_8-9-18

GENERAL INSTALLATION NOTES

Recommended Guidelines For All Installations:

- 1. REVIEW CONTRACT DOCUMENTS.** Check shop drawings, installation instructions, architectural drawings, and shipping lists to become thoroughly familiar with the project. The shop drawings take precedence and include specific details for the project. Note any *field verified* notes on the shop drawings prior to installing. The installation instructions are of a general nature and cover most conditions.
- 2. INSTALLATION.** All materials are to be installed plumb, level, and true. Install operable windows preglazed only.
- 3. BENCH MARKS.** All work should start from bench marks and/or column lines as established by the architectural drawings and the general contractor with guaranteed accuracy. Working from these datum points and lines determine:
 - a) The plane of the wall in reference to offset lines provided on each floor.
 - b) The finish floor lines in reference to bench marks on the outer building columns.
 - c) Mullion spacing from both ends of masonry opening to prevent dimensional build-up of daylight opening.
- 4. FIELD WELDING.** All field welding must be adequately shielded to avoid any splatter on glass or aluminum. Results will be unsightly and/or structurally unsound. Advise general contractor and other trades accordingly. All field welds of steel anchors must receive touch-up paint (zinc chromate) to avoid rust.
- 5. SURROUNDING CONDITIONS.** Make certain that construction which will receive your materials is in accordance with the contract documents. If not, notify the general contractor in writing and resolve differences before proceeding with work.
- 6. ISOLATION OF ALUMINUM.** Aluminum to be placed in direct contact with uncured masonry or incompatible materials should be isolated with a heavy coat of zinc chromate or bituminous paint.
- 7. SEALANTS.** Sealants must be compatible with all materials with which they have contact, including other sealant surfaces. Consult with sealant manufacturer for recommendations relative to joint size, shelf life, compatibility, cleaning, priming, tooling, adhesion, etc. It is the responsibility of the **Glazing Contractor** to submit a statement from the sealant manufacturer indicating that glass and glazing materials have been tested for compatibility and adhesion with glazing sealants, and interpreting test results relative to material performance, including recommendations for primers and substrate preparation required to obtain adhesion. The chemical compatibility of all glazing materials and framing sealants with each other and with like materials used in glass fabrication must be established. This is required on every project.
- 8. FASTENING.** Within the body of these instructions "fastening" means any method of securing one part to another or to adjacent materials. Only those fasteners used within the system are specified in these instructions. Due to the varying perimeter conditions and performance requirements, perimeter and anchor fasteners are not specified in these instructions. For perimeter and anchor fasteners refer to the shop drawings or consult the fastener supplier.
- 9. BUILDING CODES.** Due to the diversity in state/provincial local, and federal laws and codes that govern the design and application of architectural products, it is the responsibility of the individual architect, owner, and installer to assure that products selected for use on projects comply with all the applicable building codes and laws. U.S. Aluminum exercises no control over the use or application of its products, glazing materials, and operating hardware and assumes no responsibility thereof.
- 10. EXPANSION JOINTS.** Expansion joints and perimeter seals shown in these instructions and in the shop drawings are shown at normal size. Actual dimensions may vary due to perimeter conditions and/or difference in metal temperature between the time of fabrication and the time of installation. Gaps between expansion members should be based on temperature at time of installation.
- 11. COORDINATION WITH OTHER TRADES.** Coordinate with the general contractor any sequence with other trades which offset curtain wall installation (i.e. fire proofing, back-up walls, partitions, ceilings, mechanical ducts, converters, etc.)
- 12. CARE AND MAINTENANCE.** Final cleaning of exposed aluminum surfaces should be done in accordance with AAMA 609.1 for anodized aluminum and 610.1 for painted aluminum.

HANDLING, STORAGE, AND PROTECTION

The following precautions are recommended to protect the material against damage. Following these precautions will help ensure early acceptance of your products and workmanship.

A. HANDLE CAREFULLY.

All aluminum materials at job site must be stored in a safe place, well removed from possible damage by other trades. Cardboard wrapped or paper interleaved materials must be kept dry.

B. CHECK ARRIVING MATERIALS.

Check for quantities and keep records of where various materials are stored.

C. KEEP MATERIALS AWAY FROM WATER, MUD, AND SPRAY.

Prevent cement plaster or other materials from damaging the finish.

D. PROTECT THE MATERIALS AFTER ERECTION.

Protect erected frame with polyethylene or canvas splatter screen. Cement, plaster, terrazzo, other alkaline solutions, and acid based materials used to clean masonry are harmful to the finish. If any of these materials come in contact with the aluminum, immediately remove with water and mild soap.

IMPORTANT: READ THIS MANUAL THOROUGHLY BEFORE BEGINNING INSTALLATION

TABLE OF CONTENTS

PARTS IDENTIFICATION	5 - 6
SITE PREPARATION	7
SINGLE / DOUBLE DOOR WITH FRAME INSTALLATION	8 - 10
Threshold Installation	9
Door Header Installation	9
Doorway Jamb at Wall Installation	10
Apply Clad	10
DOOR PREPARATION	11 - 12
DOOR INSTALLATION	13
DOOR WITH SIDELITE INSTALLATION	14 - 22
Subsill Installation	15
Top Anchor and Header Installation	16
Wall Jamb Installation	17
Top and Bottom Rail Installation	18
Sidelite Glass Installation	19
Doorway Jamb at Sidelite Installation	20 - 21
Doorway Jamb at Wall Installation	21
Clad Installation	22
TRANSOM DOOR With SIDELITES INSTALLATION	23 - 27
Transom Jamb Installation	24
Transom Top Rail Installation	25
Transom Header Installation	25
Transom Glass Installation	26
Support Fin Installation	27
FIXED LITE INSTALLATION	28 - 31
Fixed Lite Top and Bottom Rail Installation	29
Fixed Lite Glass Installation	30
Intermediate Vertical Mullion Installation	31
90° INSIDE AND OUTSIDE CORNER INSTALLATION	32
PERIMETER SEALING	33
GLASS REPLACEMENT FOR DOORS	34 - 36
Remove Damaged Glass	34
Install Replacement Glass	35 - 36

PARTS IDENTIFICATION

DOORWAY AND WALL JAMB PARTS

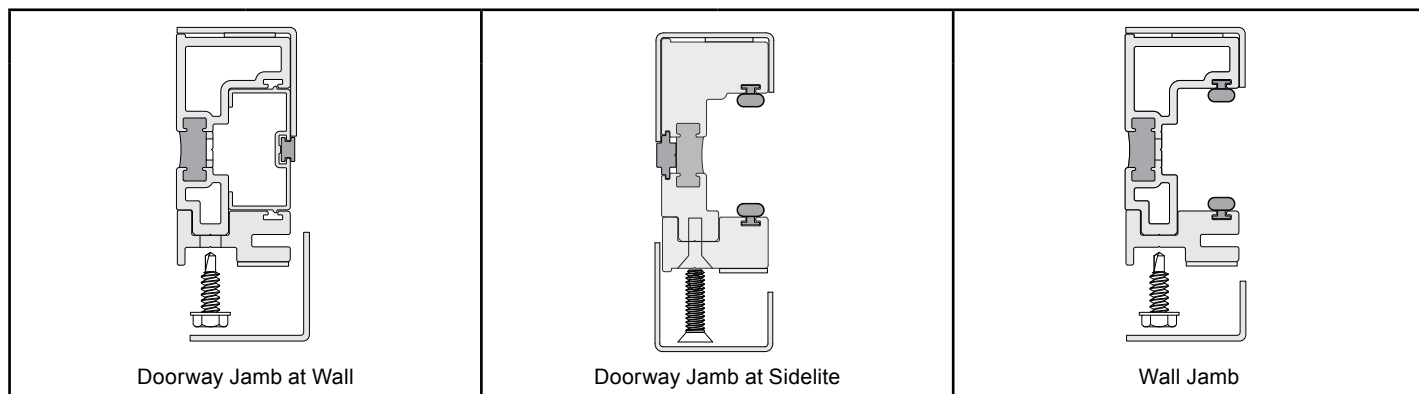

DOORWAY HORIZONTAL PARTS

SIDELITE HORIZONTAL PARTS

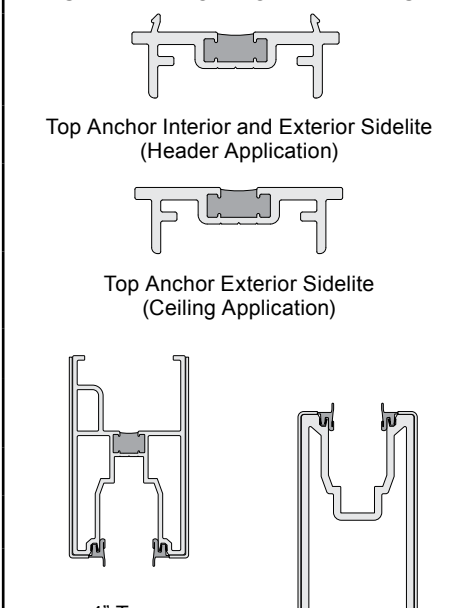
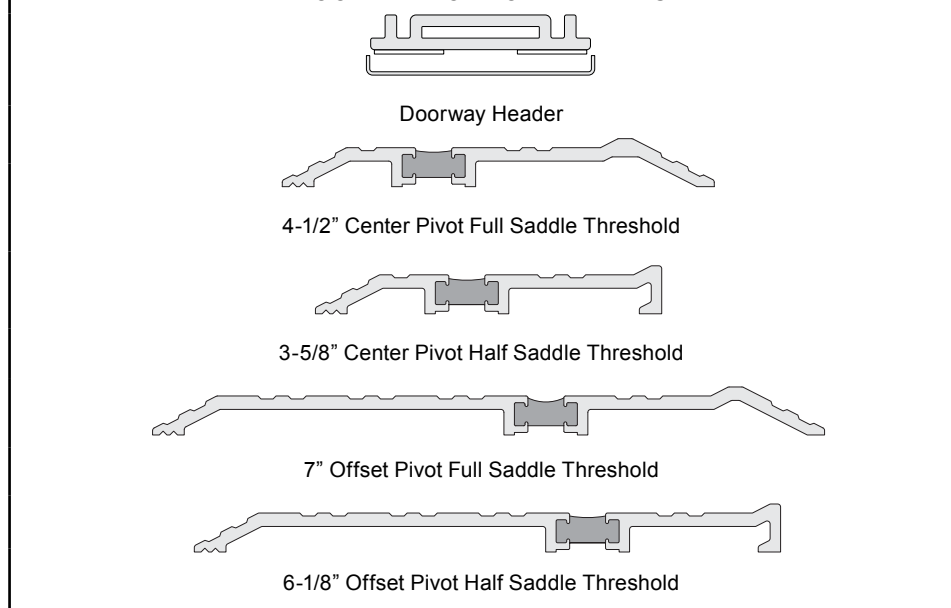

DOOR PARTS

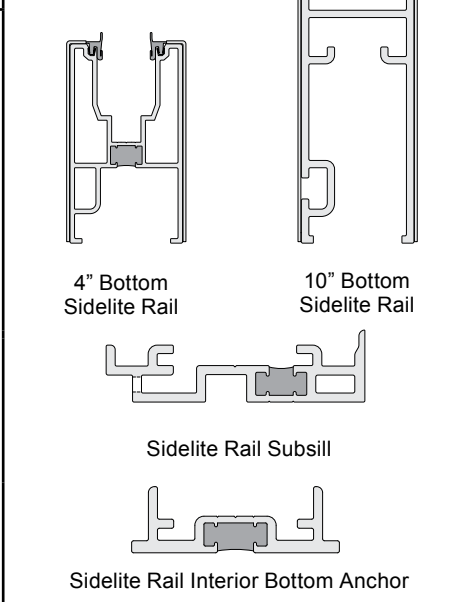
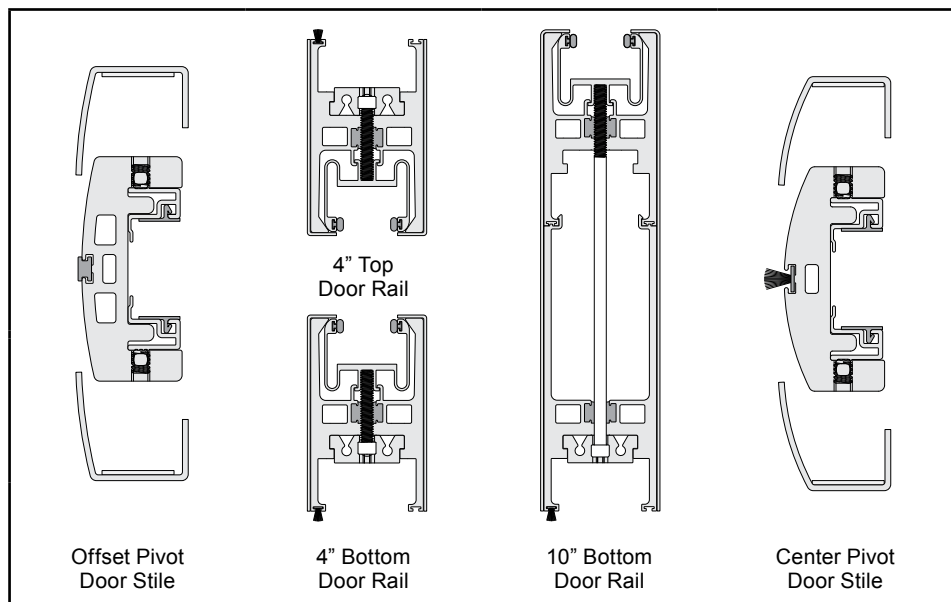



NOTE: For replacement parts, please contact Technical Sales at (800) 582-7501.

PARTS IDENTIFICATION (CONTINUED)

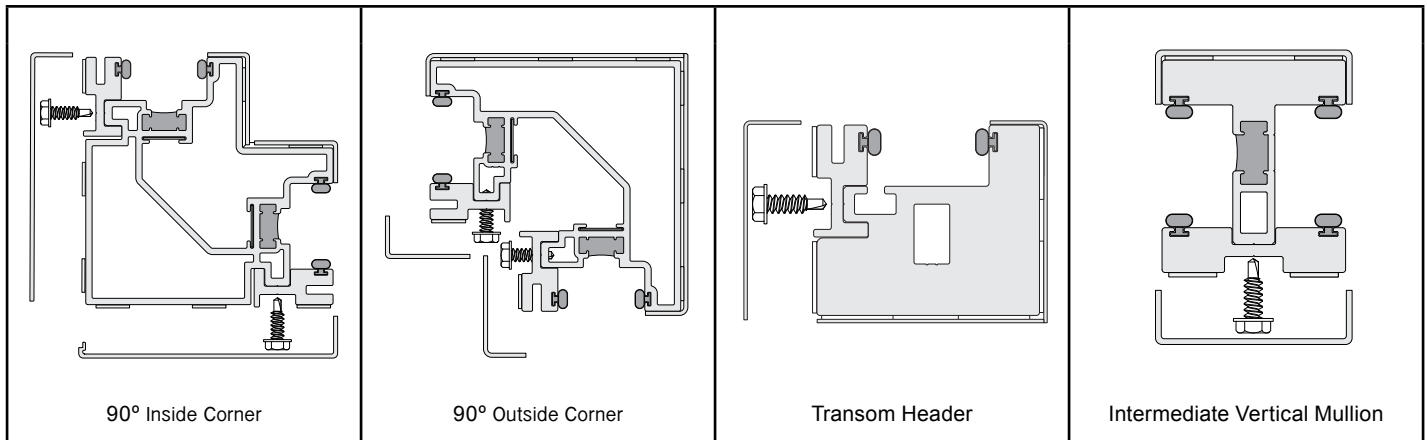
CORNER, TRANSOM AND INTERMEDIATE VERTICAL FRAME PARTS

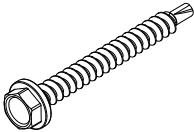

ACCESSORIES

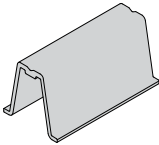
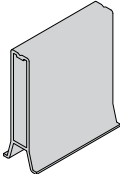
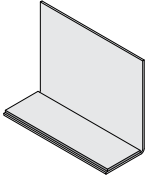
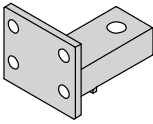
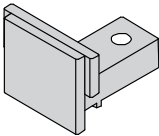
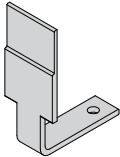
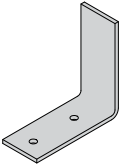
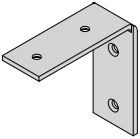
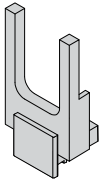
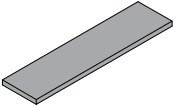
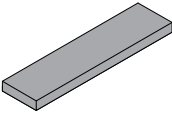
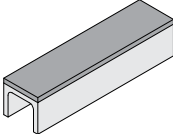
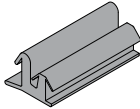
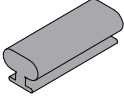
<p>Part No. 10X112HHDTEK</p>  <p>#10 x 1-1/2" Hex Washer Self Drilling Screw (Attach Fastening Clips and Intermediate Shear Clips)</p>	<p>Part No. 20092003</p>  <p>#10-16 x 5/8" Hex Washer Self Drilling Screw (Attach Removable Stop)</p>	 <p>4" Sidelite Rail Fastening Clip</p>	 <p>10" Sidelite Rail Fastening Clip</p>
 <p>End Dam</p>	 <p>Doorway Jamb Shear Clip (Used at Sidelite Doorway Jamb)</p>	 <p>90° Corner Shear Clip</p>	 <p>Intermediate Mullion Shear Clip</p>
 <p>Wall Jamb to Wall Jamb Shear Clip</p>	 <p>Door jamb to Wall Jamb Shear Clip</p>	 <p>Recessed Shear Clip</p>	 <p>Neoprene Edge Block (Sidelite Vertical)</p>
 <p>Setting Block (Door)</p>	 <p>Setting Block (Sidelite Rail)</p>	<p>PART # GG12500</p>  <p>Gasket (Sidelite Rail)</p>	<p>PART # WH34200300</p>  <p>Foam Gasket (Removable Stop)</p>

NOTE: For replacement parts, please contact Technical Sales at (800) 582-7501.

SITE PREPARATION

1. Review and measure the opening.
2. Verify rough window opening size 1/2" (12.7) clearance in both width and height. Verify framing is plumb, straight, and true around opening. Measure opening at each end and at center vertically and horizontally. Make corrections to openings as required. Measure opening diagonally to check squareness. Chip concrete high points to flush and rounded corners to square.

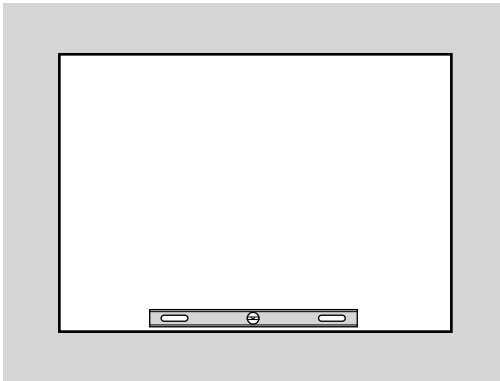

LEVEL

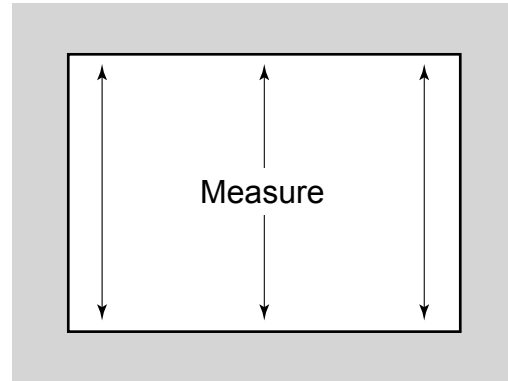

VERTICAL DIMENSION

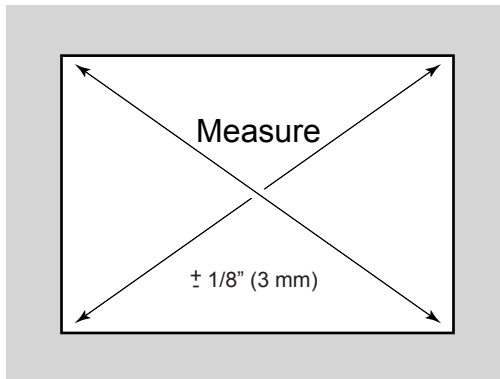

SQUARE

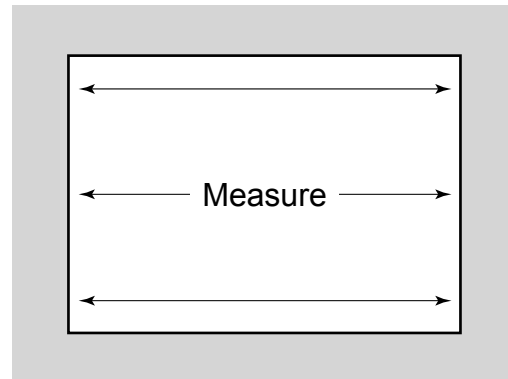

HORIZONTAL DIMENSION

SINGLE / DOUBLE DOOR WITH FRAME INSTALLATION

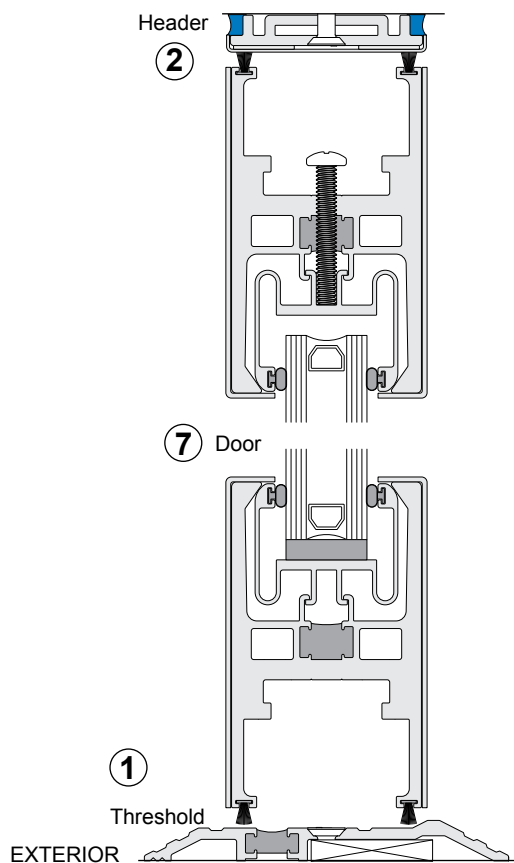

NOTE: 4" Bottom Rail Shown.
10" Bottom Rail Optional.

Door with Frame Installation Order		
①	Threshold	Page 9
②	Door Header	Page 9
③	Doorway Jamb at Wall	Page 10
④	Doorway Insert	Page 10
⑤	Jamb and Header Clad	Page 10
⑥	Door Preparation	Page 11 - 12
⑦	Door Installation	Page 13
⑧	Finishing and Sealing	Page 33

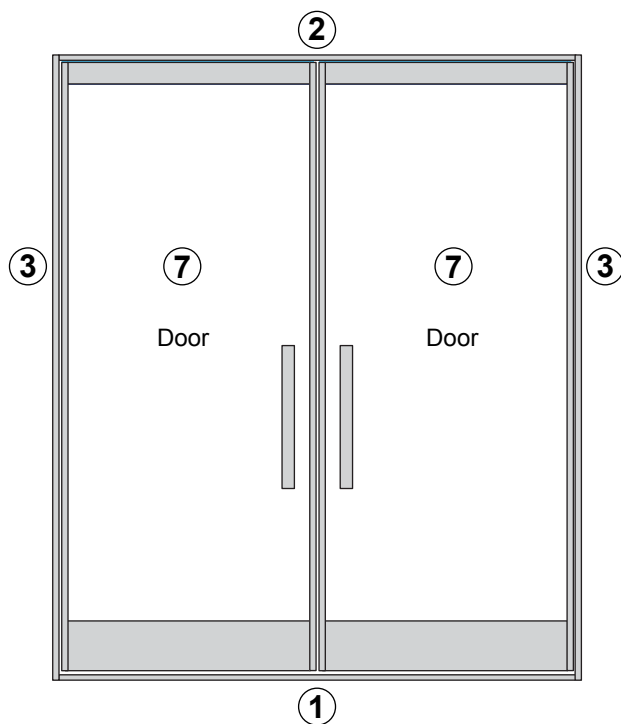
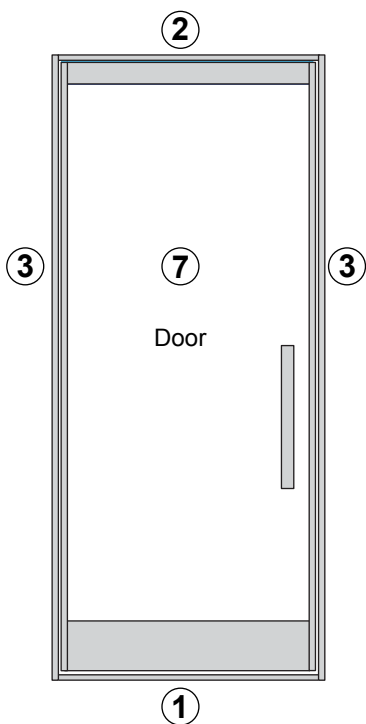
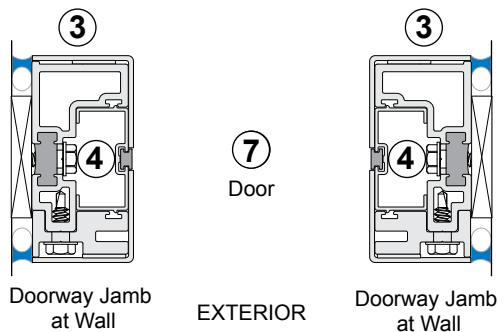

THRESHOLD INSTALLATION

NOTE: For all installations with doors, install the Threshold first to determine the location of the other components.

- ① Install the cement box and closer if applicable.
- ② Apply continuous bead of Sealant to substrate. Set Threshold while sealant is wet.
- ③ Fasten Threshold to the floor.
- ④ Seal over fastener heads.

Threshold Options



7" Offset Pivot Full Saddle



4-1/2" Center Pivot Full Saddle



6-1/8" Offset Pivot Half Saddle



3-5/8" Center Pivot Half Saddle

NOTE: Full Saddle Threshold Offset Pivot shown in illustrations.

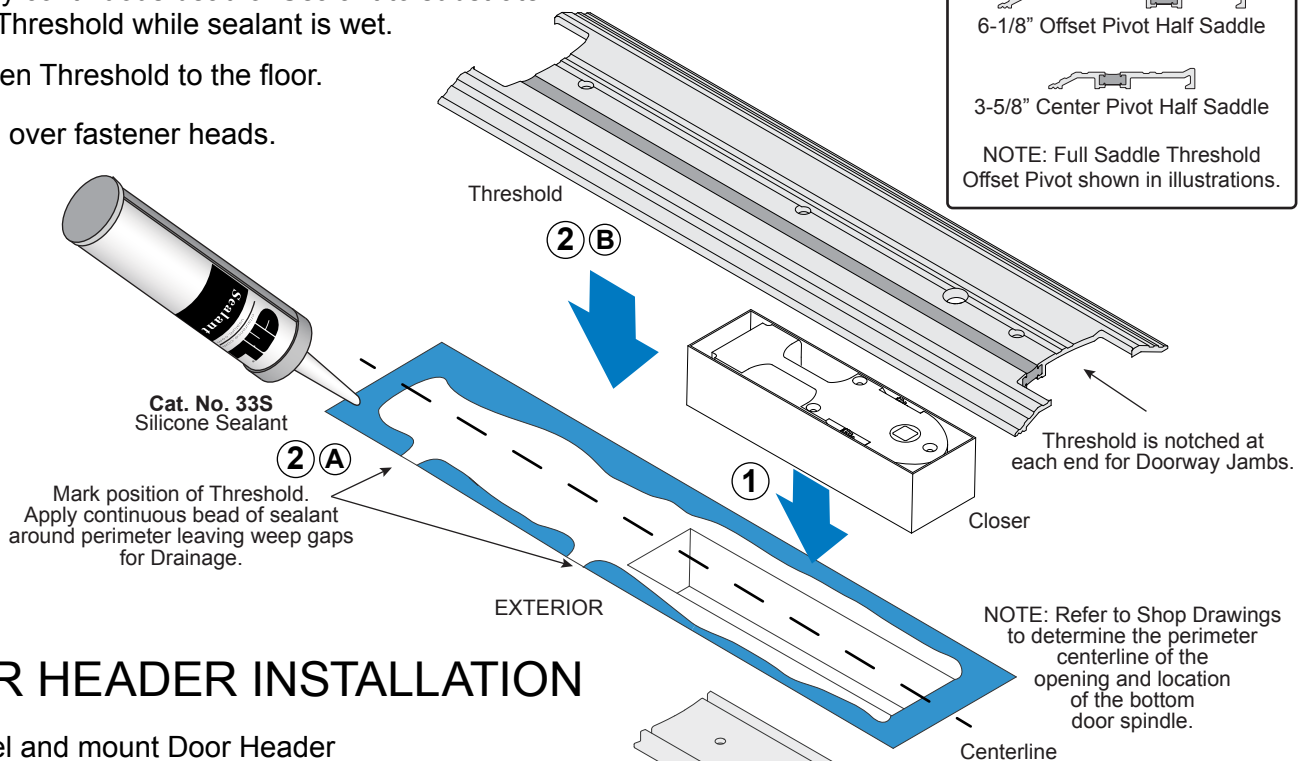

DOOR HEADER INSTALLATION

- ⑤ Level and mount Door Header directly above Threshold.

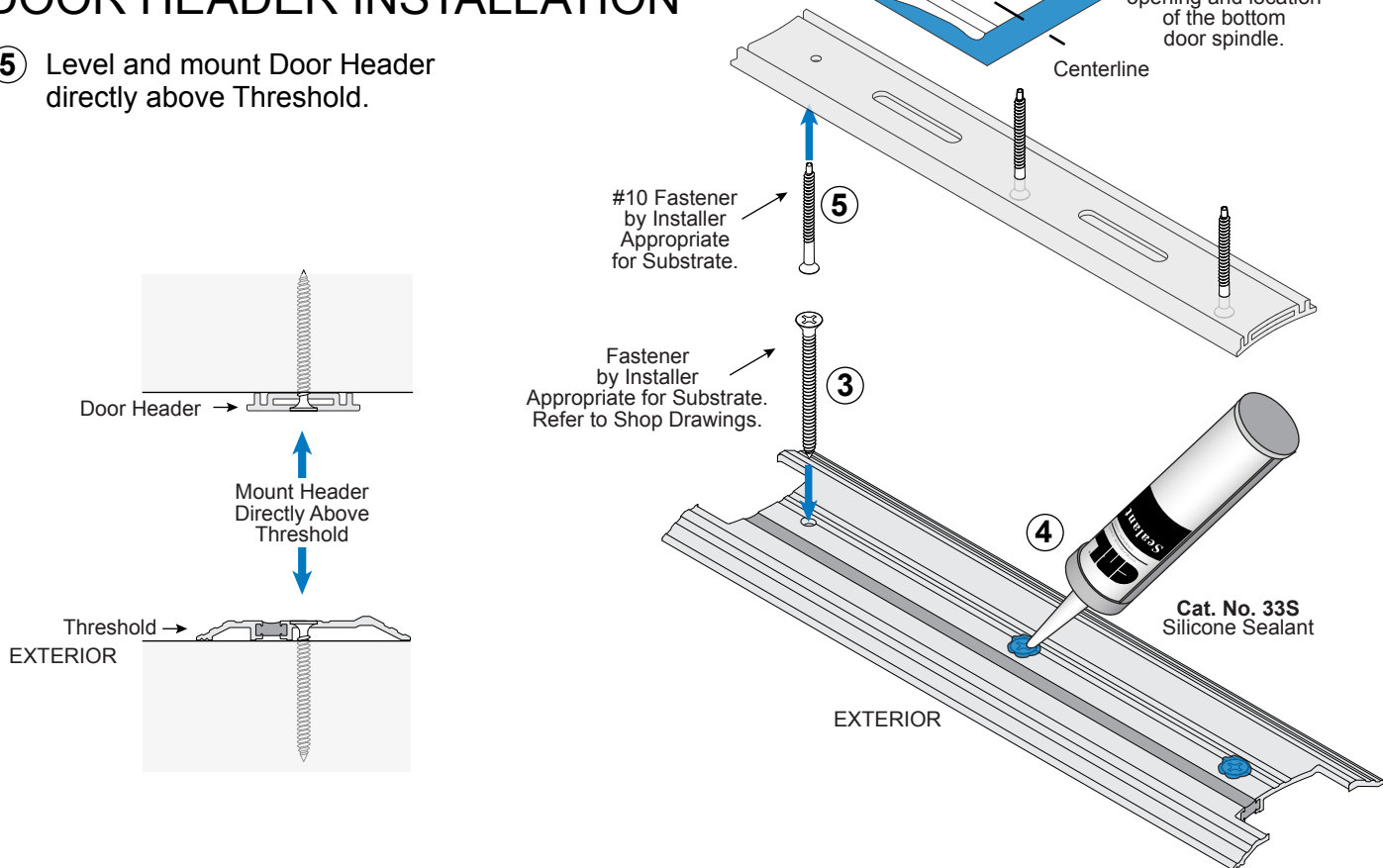

DOORWAY JAMB AT WALL INSTALLATION

- 1 Mount Doorway Jamb Main Body to wall.

NOTE: System fabricated with gap between Doorway Jamb and Header for cladding.

- 2 Install Removable Stop.

- 3 Install Doorway Filler.

Insert Cat. No. PHS4 Shim at each hole. Turn parallel to Doorway Jamb.

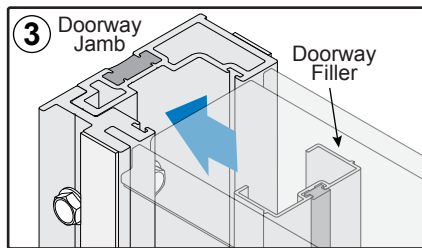
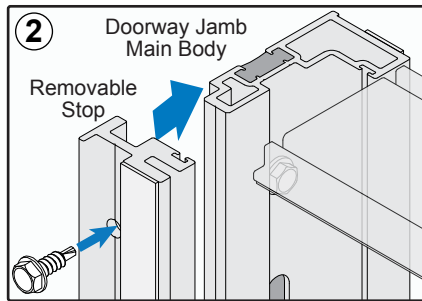

APPLY CLAD

- 4 Apply Clad to Doorway Jamb.

- 5 Apply Clad to Header.

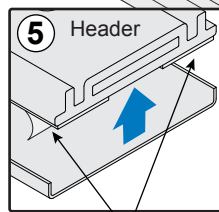
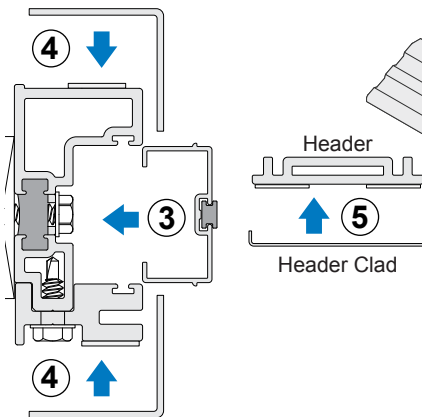

Remove liner from VHB Tape to apply Cladding. Roll On Pressure = 15 Pounds Per Linear Inch.

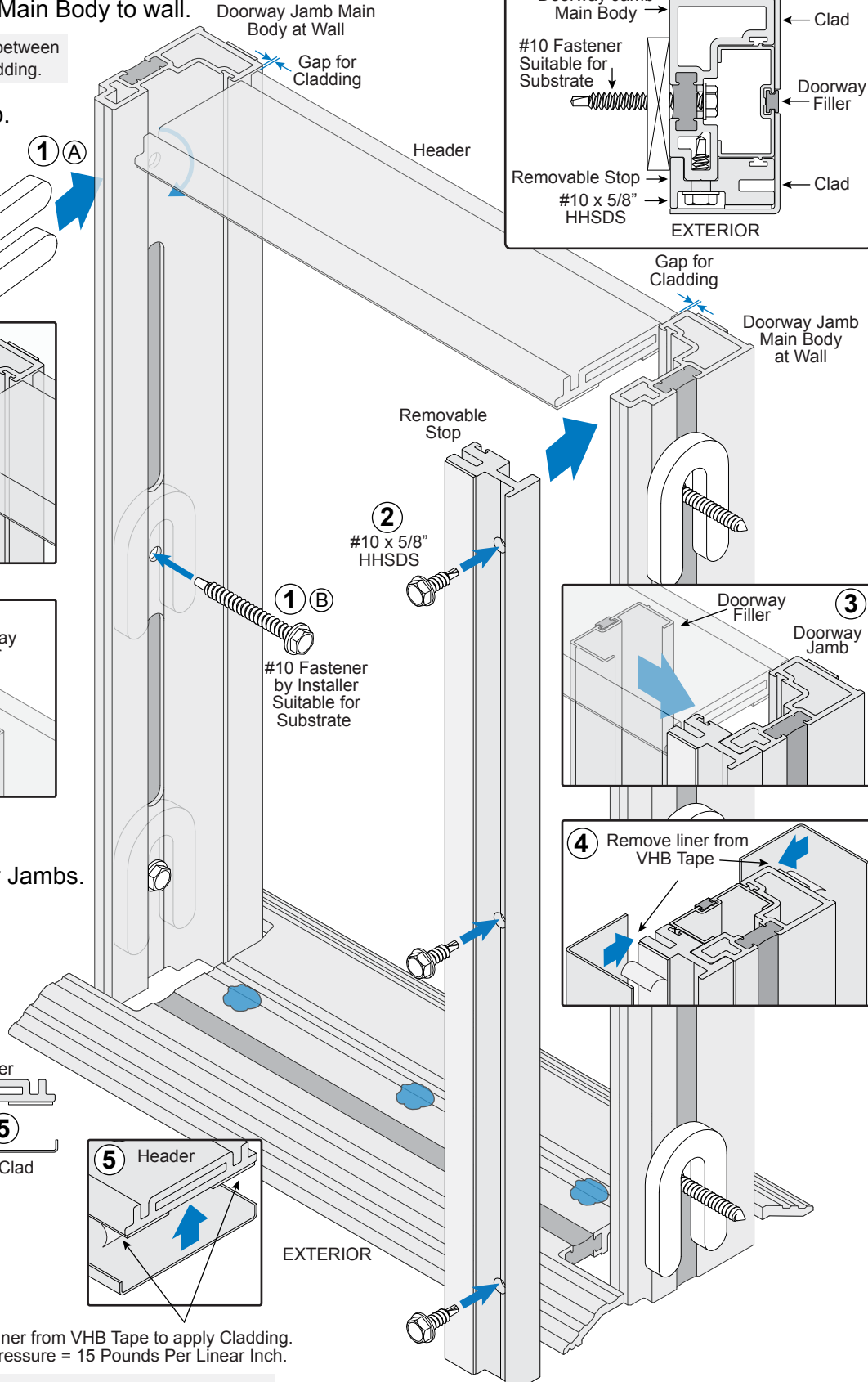
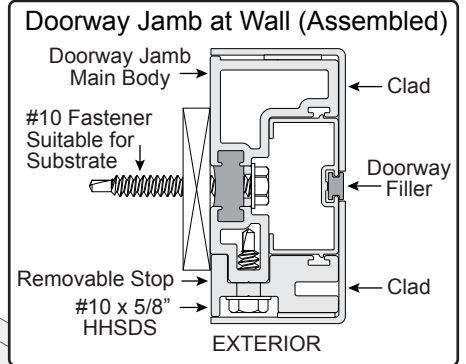

NOTE: Clad must be installed on Door Header before hanging doors. Vertical and Doorway Jamb may be clad after doors are hung.

DOOR PREPARATION

Unpacking

The doors for the Entice System are shipped fully assembled and glazed. The glass may shift during shipping so it is important to follow the preparation procedures to ensure the door is square. Use two or more people to lift doors. NOTE: Clad on vertical stiles is applied after door is installed.

Make Sure Door is Square

Measure Door to make sure it is square.

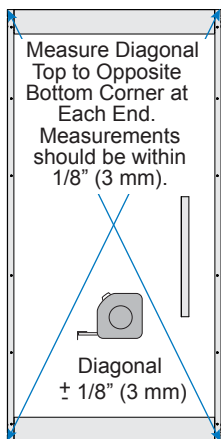

NOTE: Use a Phillips Screwdriver to turn Adjuster Screw until it is firmly touching the top of the glass. This will hold glass in place and the door square.

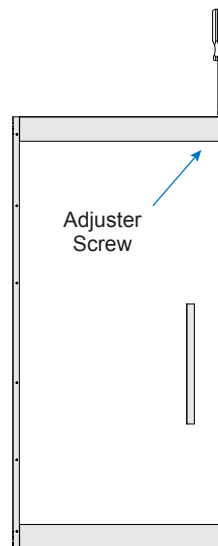

NOTE: If door is not square, follow instructions on Page 32 to adjust.

Cut the Capillary Tube

A breathing tube is installed to stabilize the glass panel during travel. Cut and seal tube before installation.

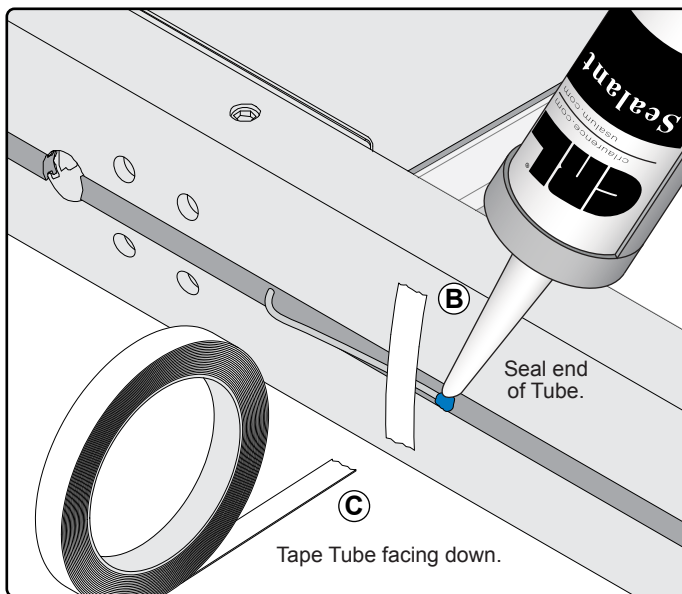
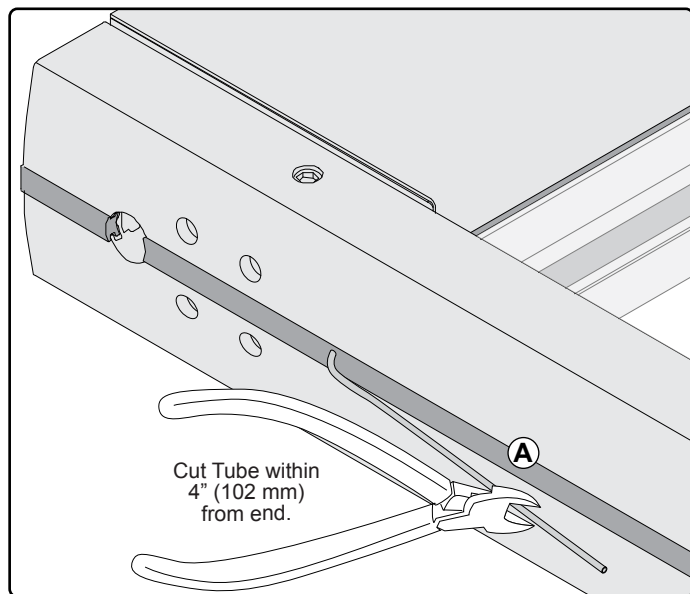

Check Handle Alignment

Panic Handles can shift during shipping. Check alignment and adjust when necessary.

DOOR PREPARATION (CONTINUED)

Adjust Door to Square

- ① In most cases, using the Adjuster Screw to raise or lower the handle side of the door will solve the problem. Use a Phillips Screwdriver to turn Adjuster Screw. Check the diagonal measurements again. If the door is square move on to installation. If not, try Step 2 below

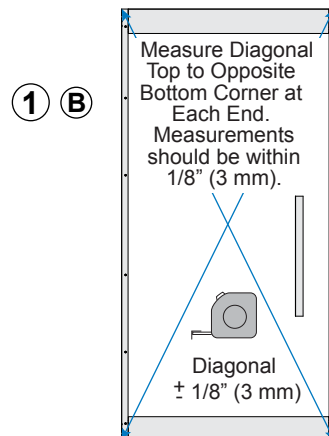
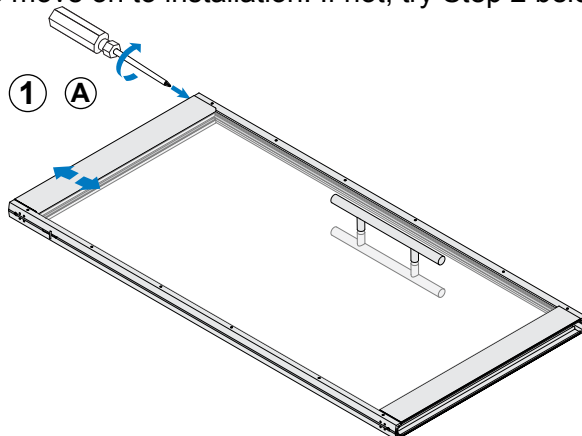

- ② Loosen the set screws on both sides of the Lead Stile with included Hex Driver. Use Phillips Screwdriver to turn Adjuster Screw. Check measurements again. If the door is square, tighten the set screws and move on to installation. If not, go to Step 3 below.

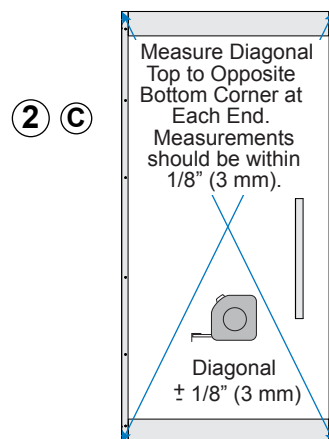
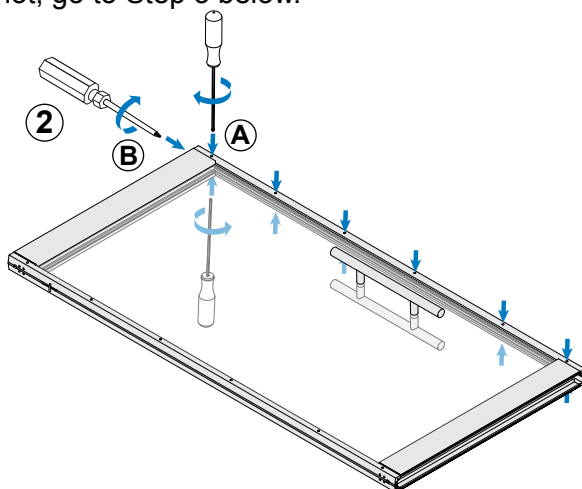

- ③ Loosen set screws on both sides of Lead and Pivot Stiles. Use Phillips Screwdriver to turn Adjuster Screw. Make sure glass fully rests on bottom setting block. Check measurements. When the door is square, tighten all set screws and move on to installation.

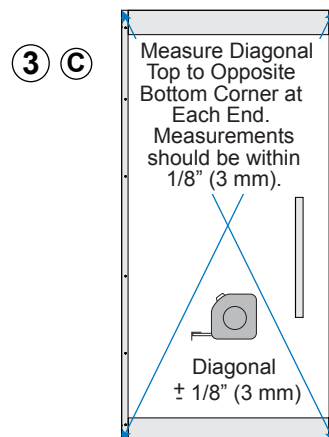
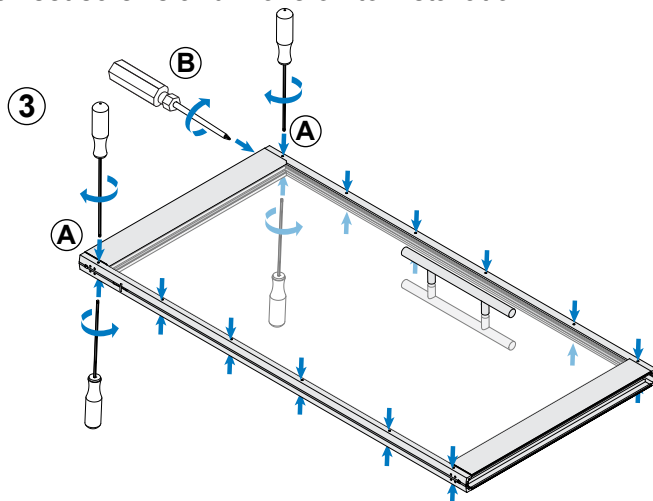

DOOR INSTALLATION

Use two or more people to lift and install the doors. After installation, follow the instructions below to adjust.
NOTE: Installation varies with hardware selection. Consult Installation Instructions in hardware packages.

- ① With the door open, adjust lateral gaps. Turn adjustment screws at hinge side top and bottom rails with included T-Handle Key. Close door again to ensure gaps are parallel and correct size.
- ② With the door open, use Adjuster Screw on upper corner of handle side of door to raise or lower that corner. Ensure door easily opens and closes.

Close door to ensure gaps are parallel and correct size.

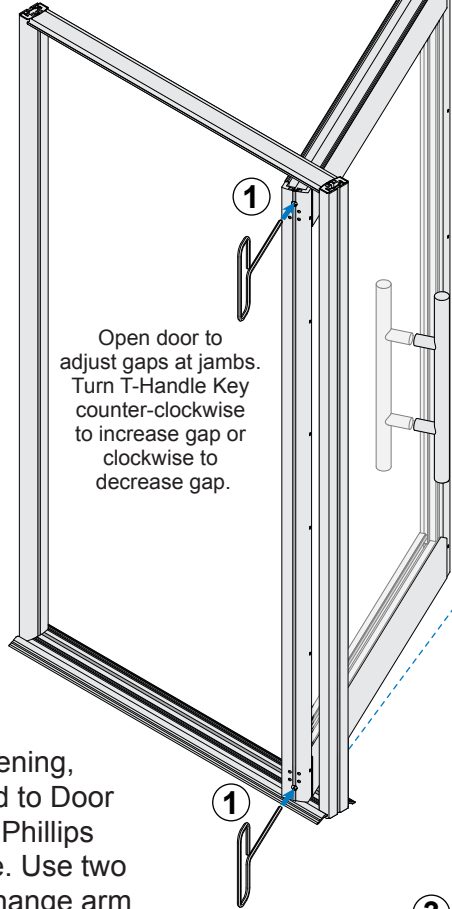
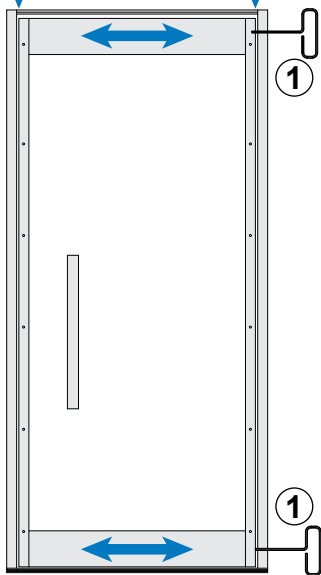

Open door to adjust gaps at jambs. Turn T-Handle Key counter-clockwise to increase gap or clockwise to decrease gap.

NOTE: Ensure Adjuster Screw is firmly touching Glass.

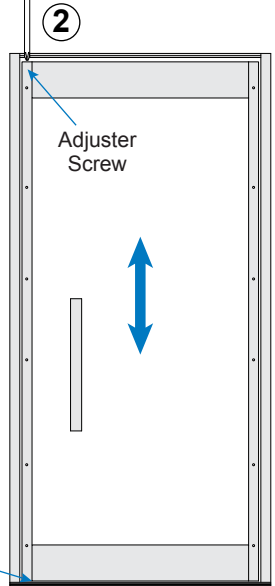

Ensure proper gap.

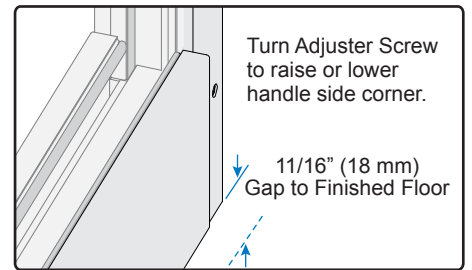

Turn Adjuster Screw to raise or lower handle side corner.

11/16" (18 mm) Gap to Finished Floor

NOTE: Over time, Doors can sag at this location. Periodically check door operation. Adjust as needed.

Center Door

- ③ To center the door in the opening, adjust angle of arm mounted to Door Rail. Loosen two Pan Head Phillips Screws holding arm in place. Use two hex bolts at end of arm to change arm angle. Securely tighten both hex bolts and then two Phillips Screws when adjustment is complete.

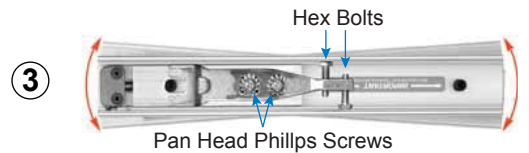

Install Clad on Vertical Door Stiles

- ④ Remove liner from VHS Tape and apply Clad to Vertical Stiles. Roll On Pressure = 15 Pounds Per Linear Inch

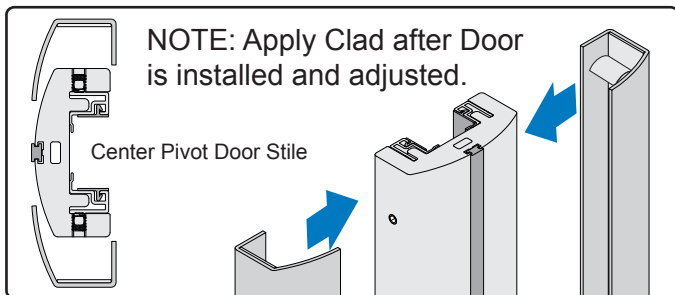

NOTE: Apply Clad after Door is installed and adjusted.

Center Pivot Door Stile

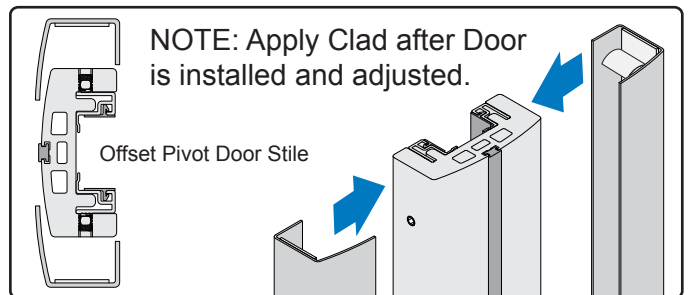

NOTE: Apply Clad after Door is installed and adjusted.

Offset Pivot Door Stile

DOOR WITH SIDELITE INSTALLATION

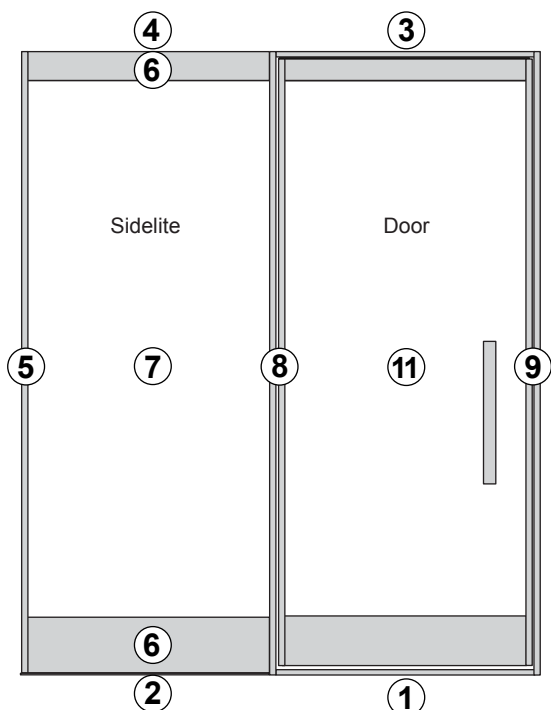

Door with Sidelite Installation Order

①	Threshold	Page 9
②	Subsill	Page 15
③	Door Header	Page 16
④	Top Anchor	Page 17
⑤	Wall Jamb	Page 17
⑥	Top and Bottom Rail	Page 18
⑦	Sidelite Glass	Page 19
⑧	Doorway Jamb at Sidelite	Page 20 - 21
⑨	Doorway Jamb at Wall	Page 21
⑩	Clad	Page 22
⑪	Door	Page 11 - 13
⑫	Finishing and Sealing	Page 33

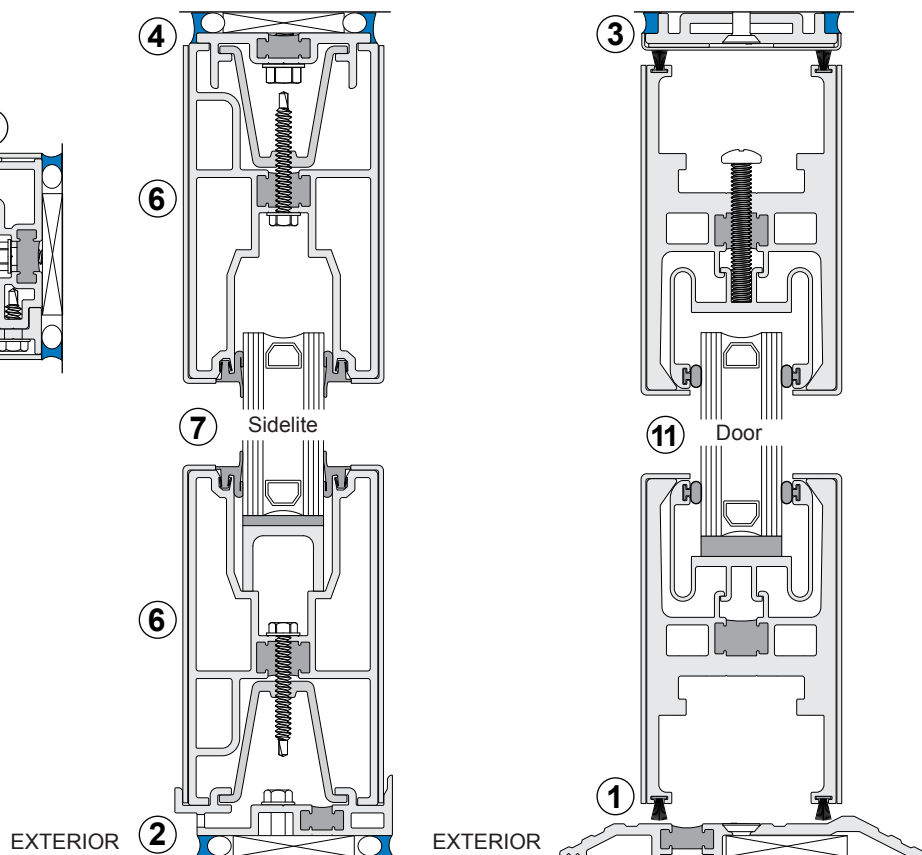
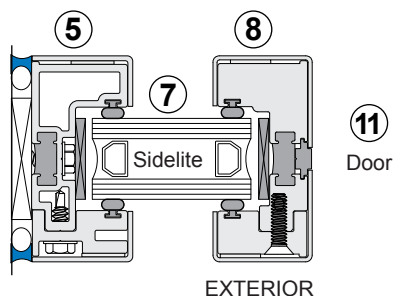

NOTE: Follow instructions on Page 7 for Site Preparation and continue on Page 9 for Threshold Installation.

SUBSILL INSTALLATION

Prepare Subsill

NOTE: Fastening Clips are packed loose with Sidelite Rails.
End Dams are packed loose with Subsill.

- 1 Slide Fastening Clips into Subsill.

NOTE: 4" Fastening Clips with 4" Sidelite Rails shown.
10" Fastening Clips used with 10" Sidelite Rails.

- 2 Seal ends of Subsill and install End Dams.
- 3 Seal and tool joint.

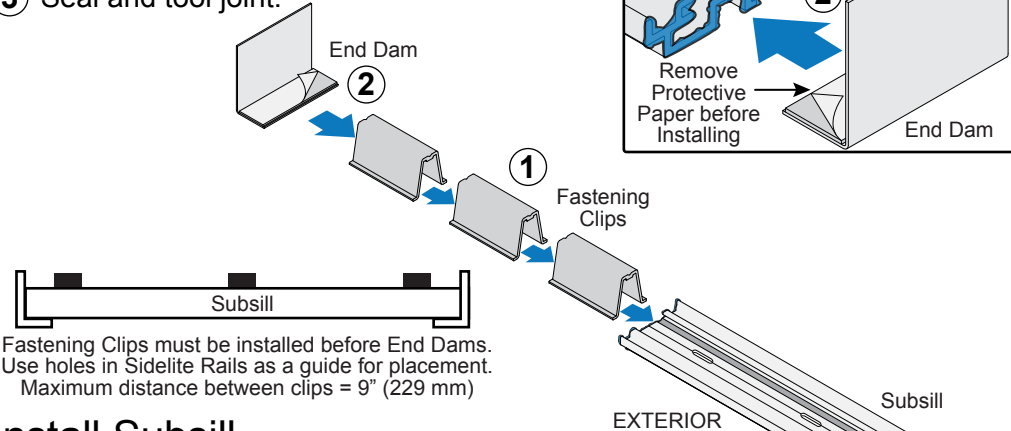

Install Subsill

NOTE: Install Threshold before installing Subsill.

- 4 Install Subsill with non-slotted hole next to Doorway.
- 5 Seal over screw heads.

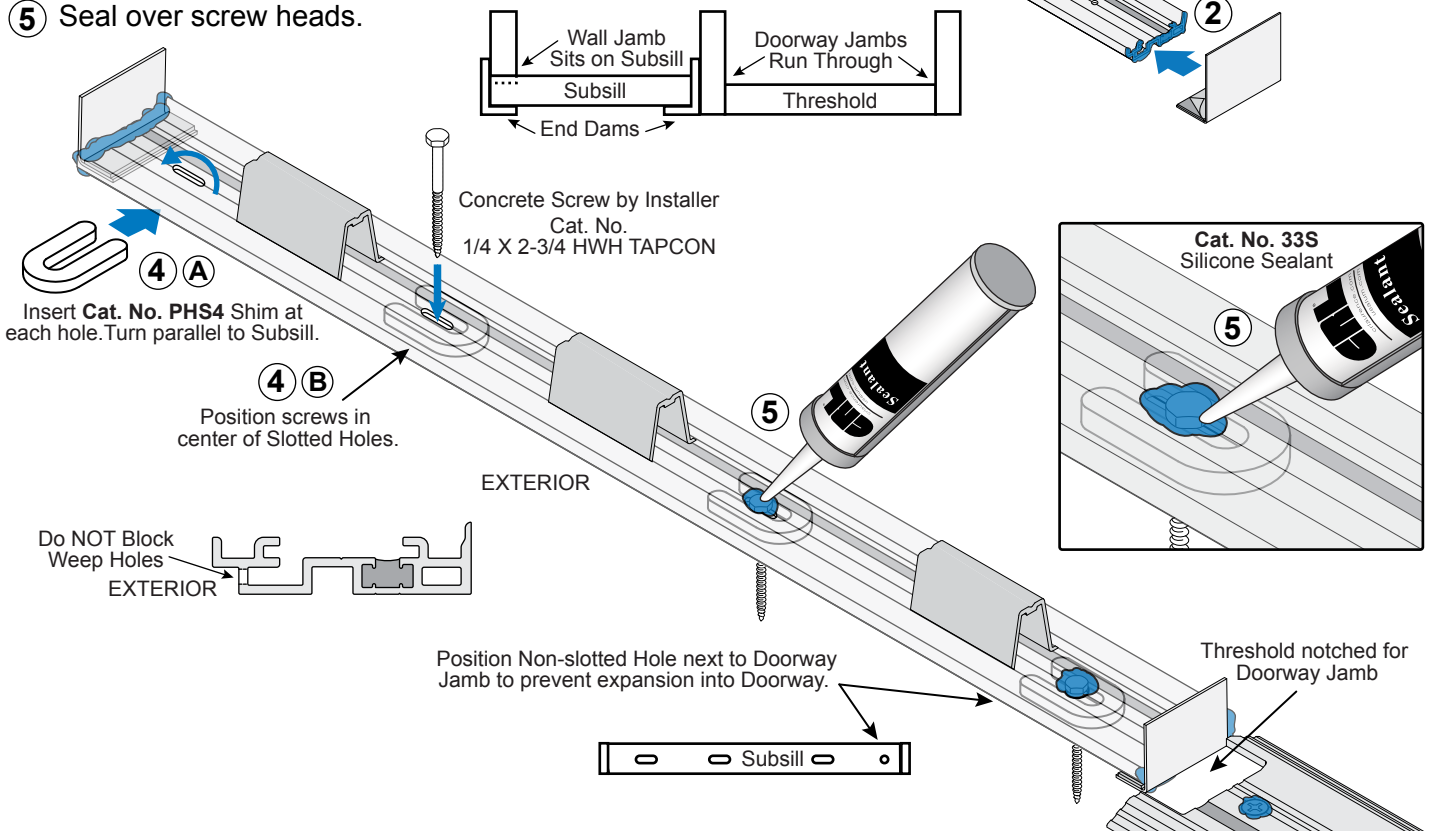

TOP ANCHOR AND HEADER INSTALLATION

NOTE: Fastening Clips are packed loose with Sidelite Rails.

- Level and mount Door Header directly above Threshold.

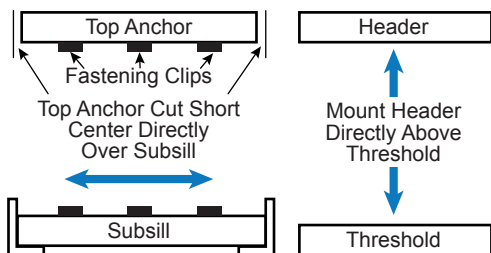

- Mount Track directly above Sub sill.
- Slide Fastening Clips into each Top Anchor.

NOTE: 4" Fastening Clips with 4" Sidelite Rails shown. Use 10" Fastening Clips with 10" Sidelite Rails.

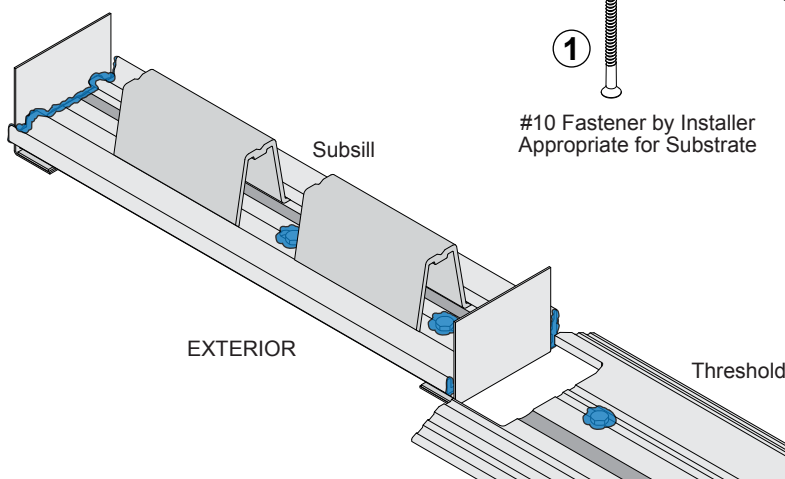
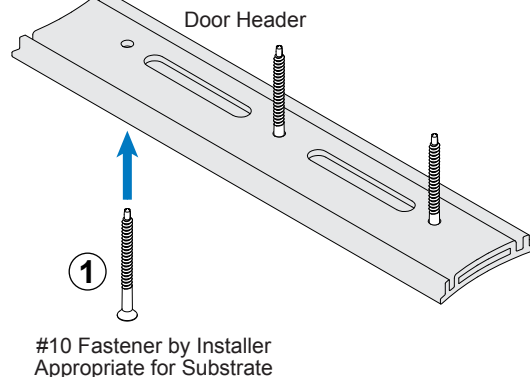
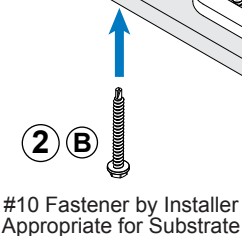
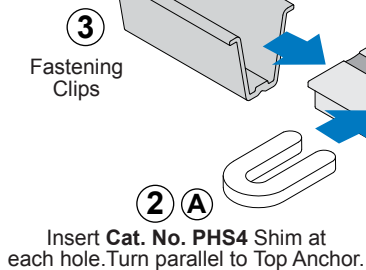
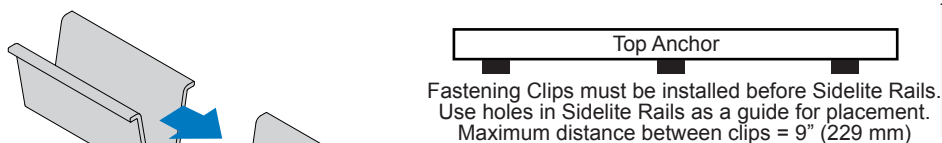
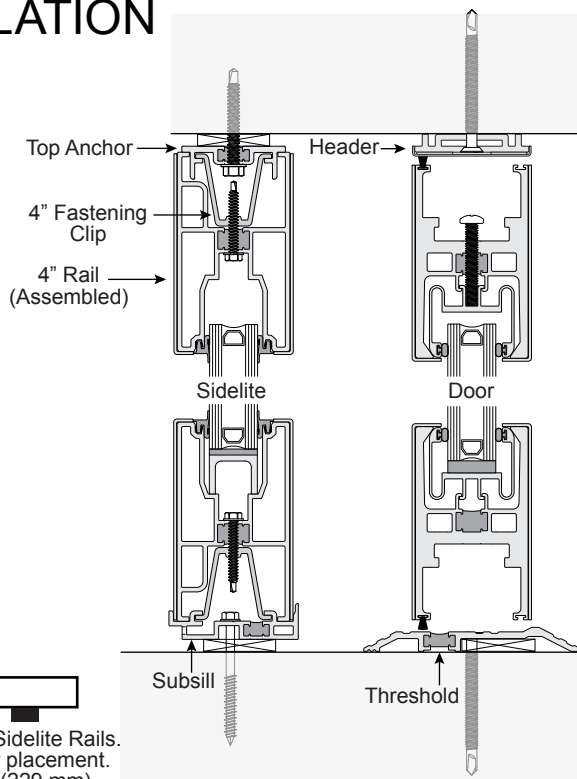

WALL JAMB INSTALLATION

- ① Fit Wall Jamb Main Body on the Subsill with cladded side facing interior. Push it tight against End Dam and wall.
- ② Shim and fasten to the wall.

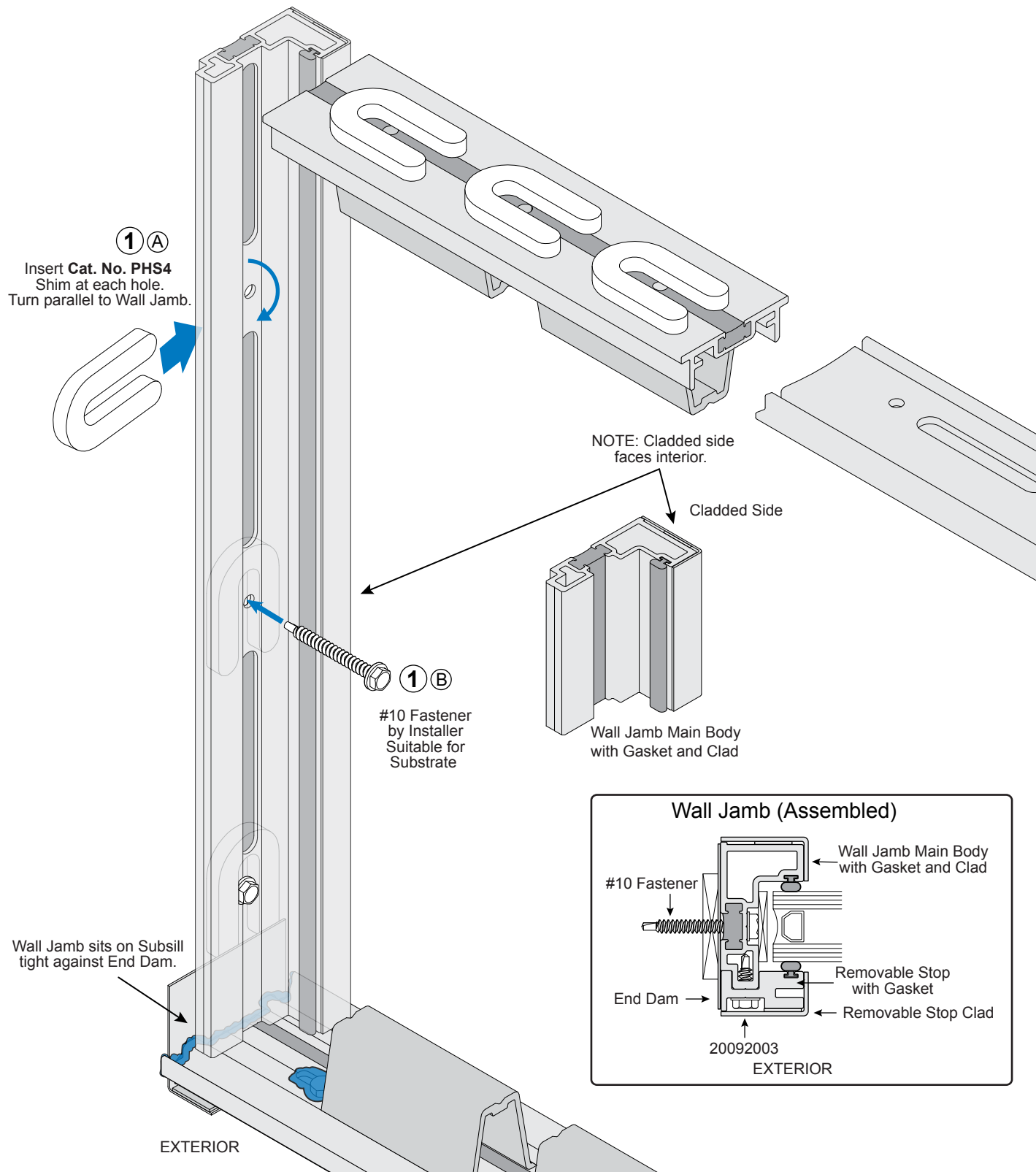
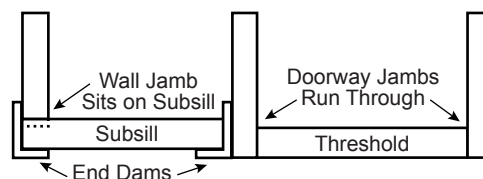

TOP AND BOTTOM RAIL INSTALLATION

Install Top and Bottom Rails with Shear Clips positioned at Doorway Jamb. Secure at each Fastening Clip with #10 x 1-1/2" Hex Washer Head Self-Drilling Screws.

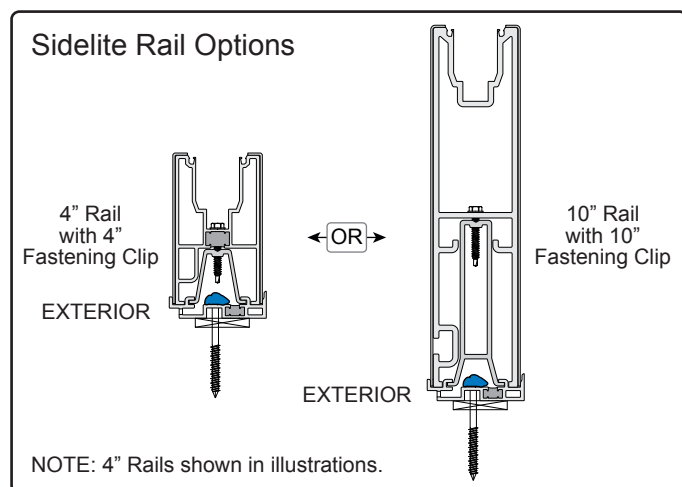
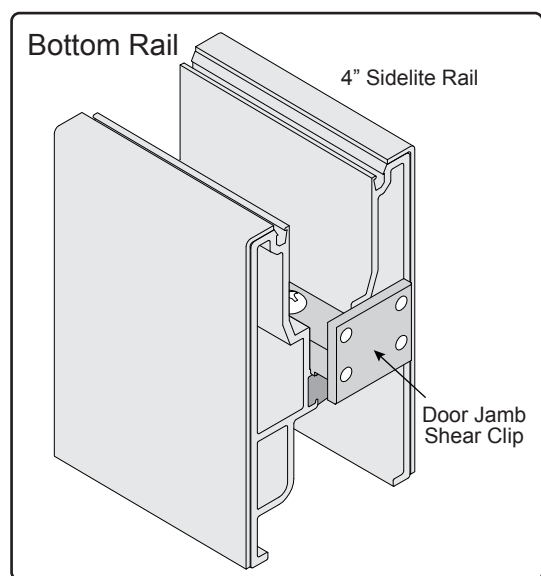
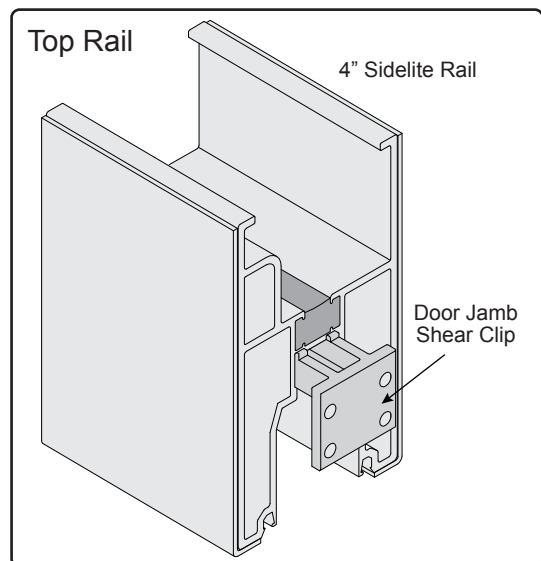

NOTE: Shear Clips also act as spacers for clad. Clips are used only where Rail butts against a Doorway Jamb.

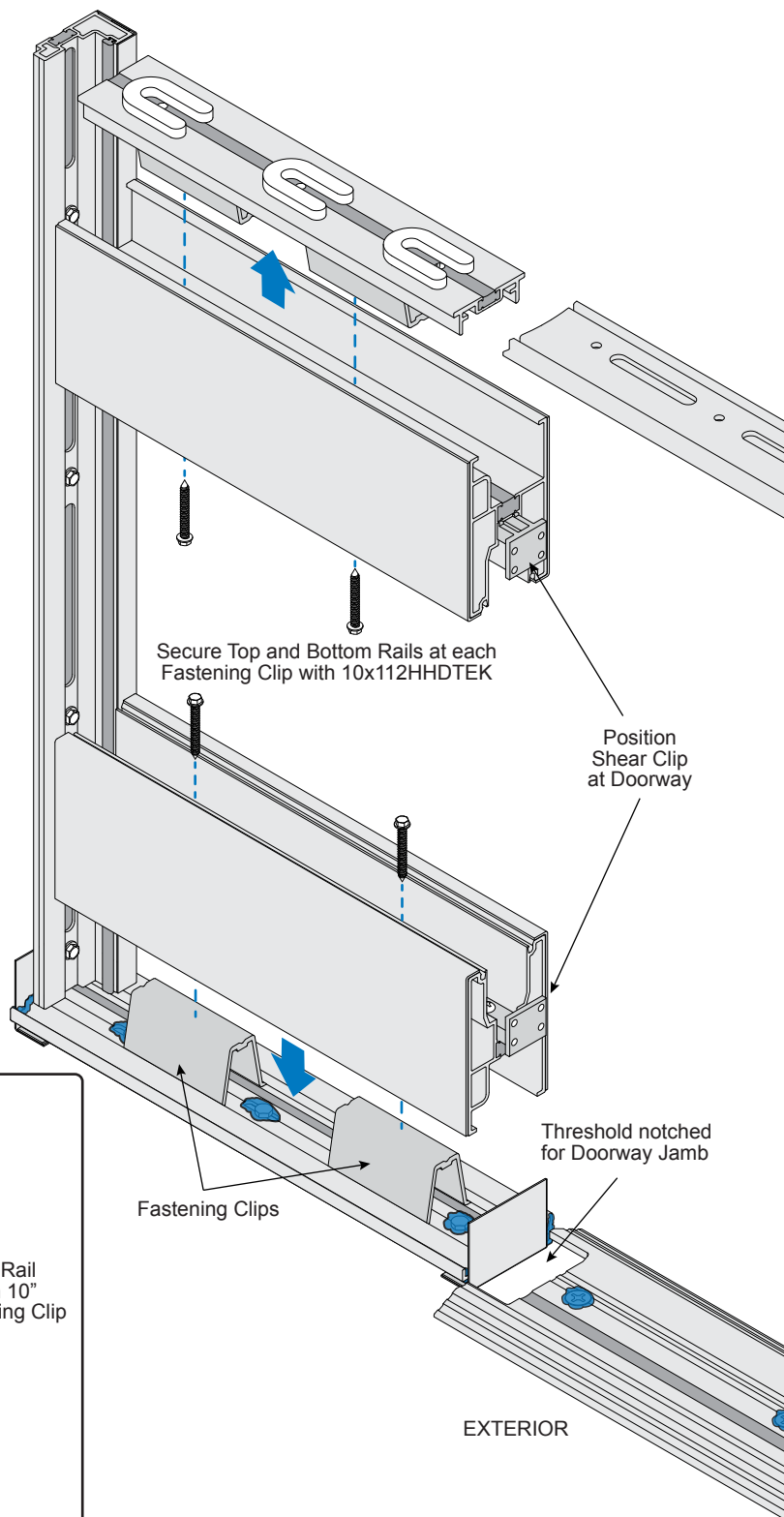

SIDELITE GLASS INSTALLATION

- ① Trim edges of the glass at face and sides with a sharp utility knife to remove any excess Silicone Sealant.
- ② Place Setting Blocks at quarter points in Bottom Rail and Edge Blocks at quarter points inside Wall Jamb pocket.

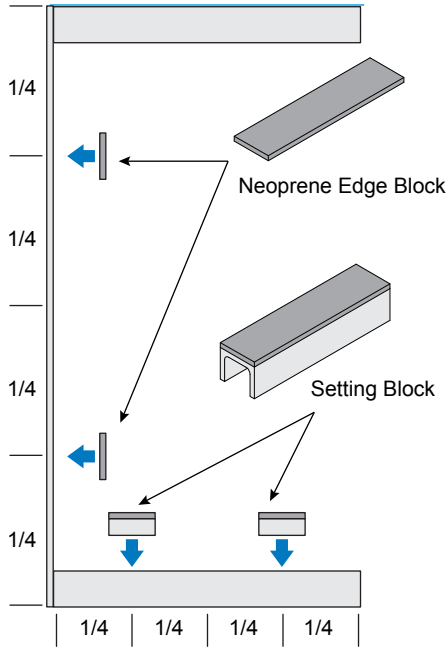
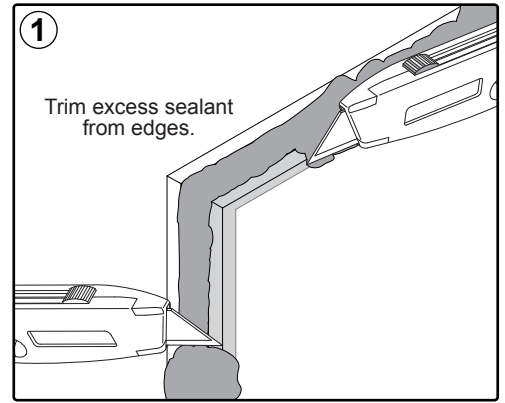

NOTE: Setting Blocks are packed loose with Sidelite Rails.

- ③ Lift and set glass into pocket. Position glass with 1/2" (12.7 mm) minimum glass bite at Wall Jamb and 1/2" (12.7 mm) minimum extended over end of Sidelite Rail.

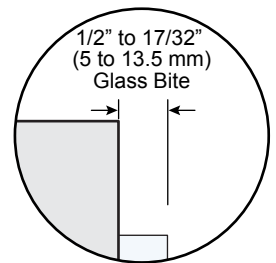
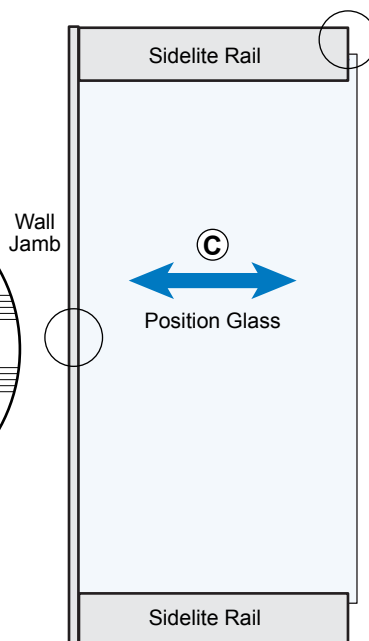
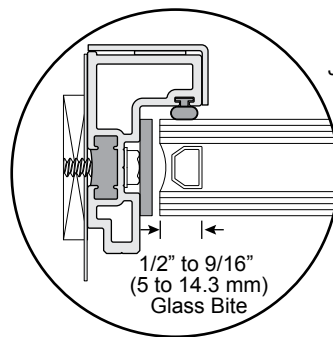
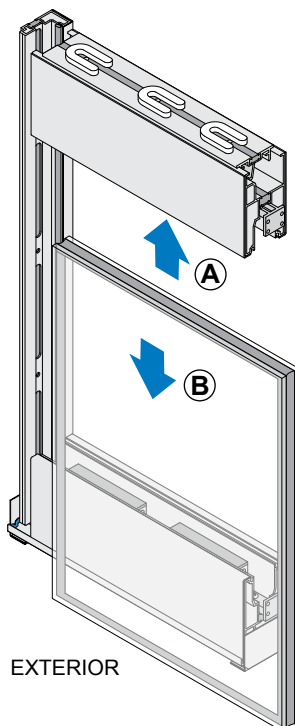

DOORWAY JAMB AT SIDELITE INSTALLATION

- ① With Slotted Holes at top, fasten Doorway Jamb Main Body to Top and Bottom Rail Shear Clips with #8-32 x 3/8" Socket Screws.
- ② Place Edge Blocks at quarter points inside Doorway Jamb pocket.
- ③ Secure Removable Stop to Wall Jamb Main Body at all predrilled hole locations.
- ④ Match holes in Doorway Removable Stop and fasten to Doorway Jamb Main Body with #10-24 x 3/4" Flat Head Phillips Machine Screws.

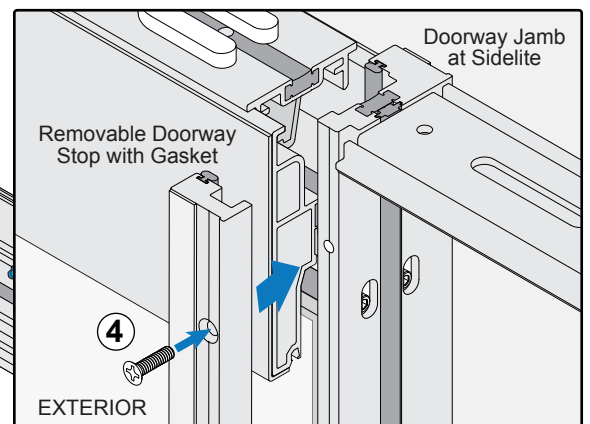
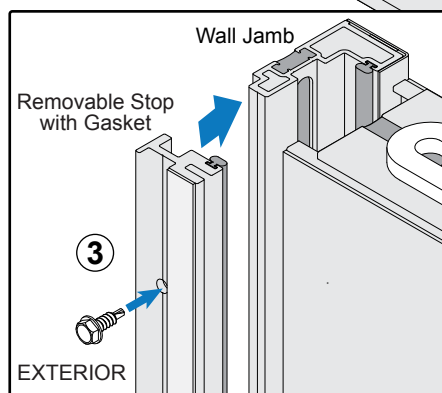
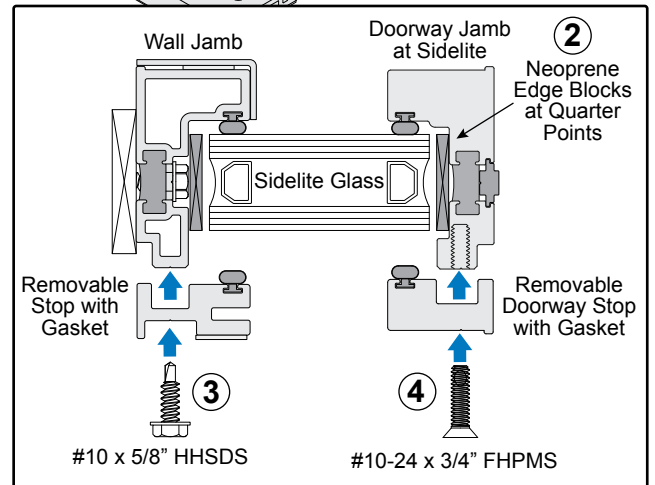
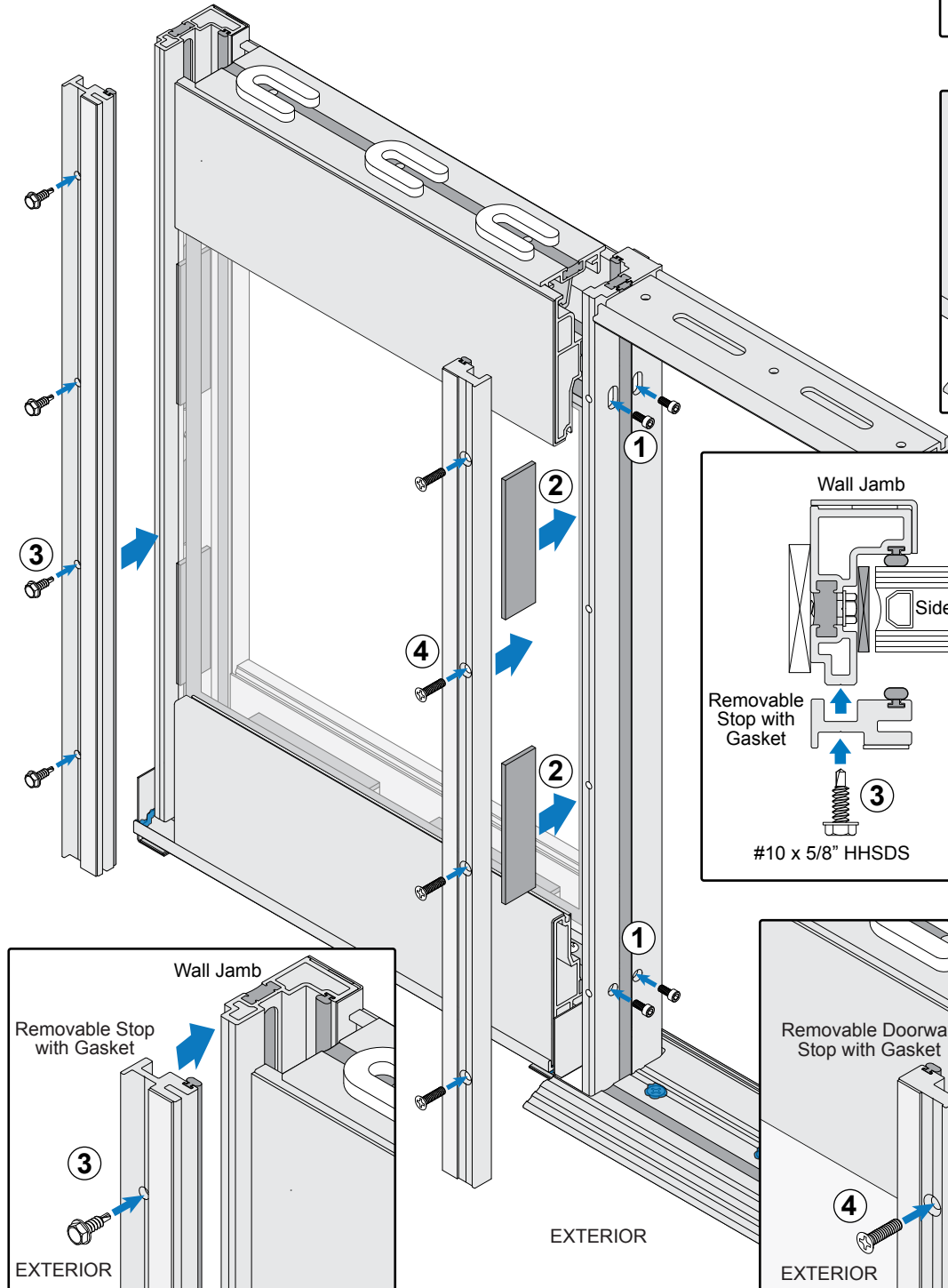
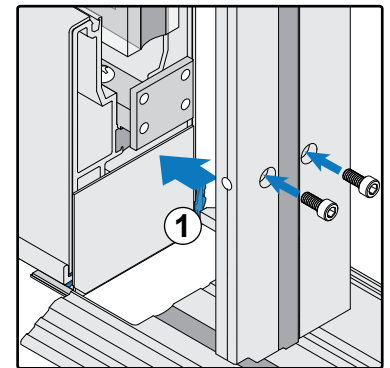
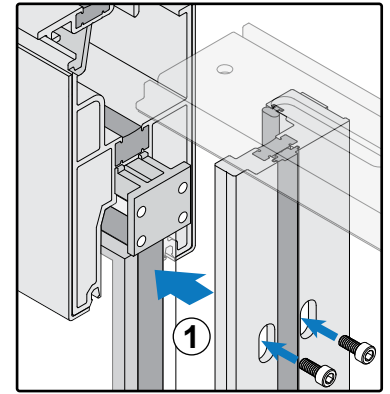

DOORWAY JAMB AT SIDELITE INSTALLATION (CONTINUED)

- ⑤ Roll GG12500 Gaskets into both sides of Top and Bottom Rails with a CRL Vinyl Roller.

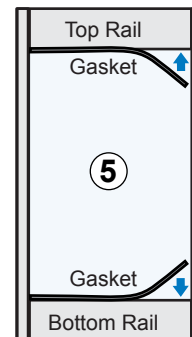
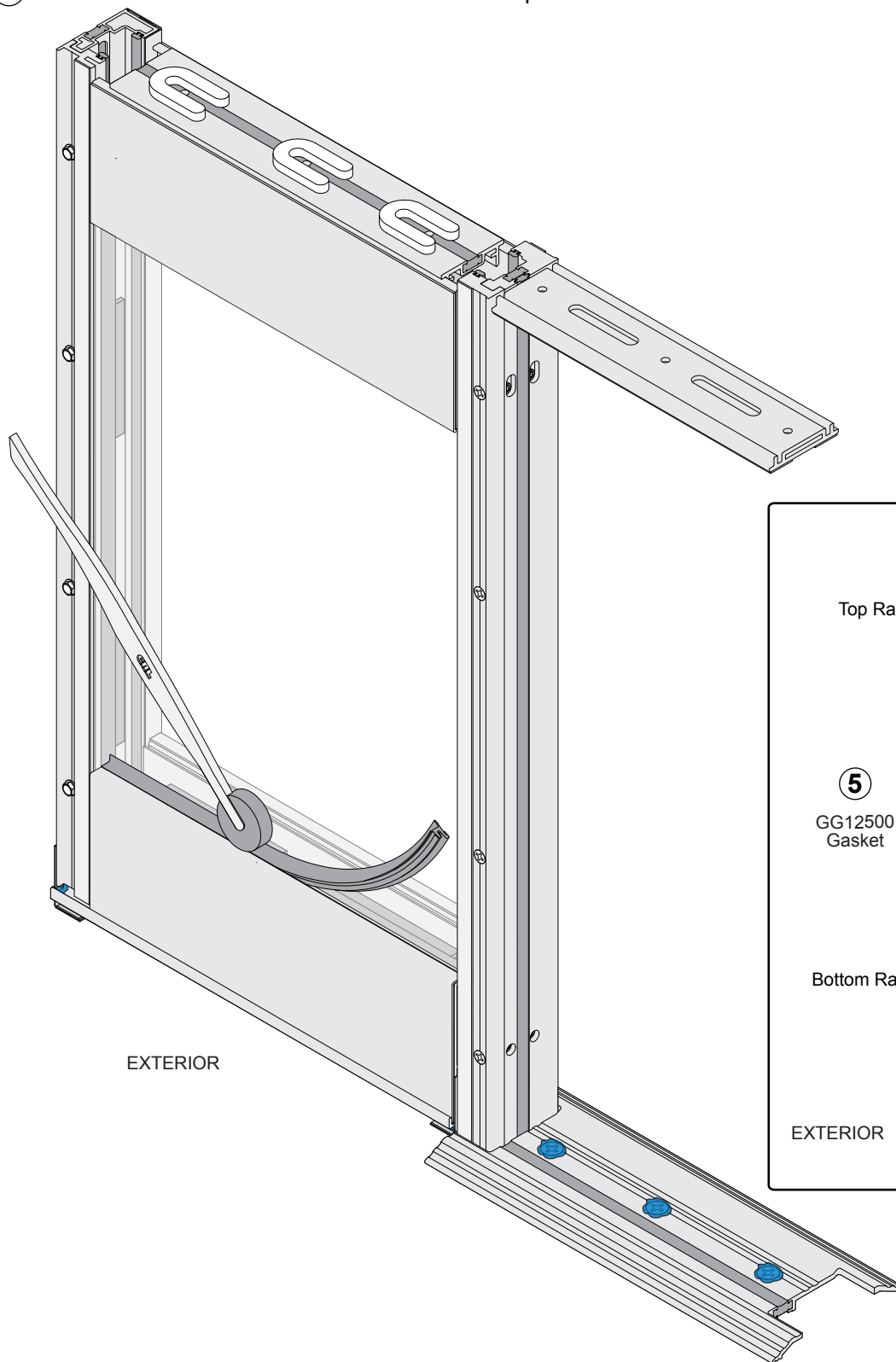

Roll Gaskets at interior and exterior Top and Bottom Rails.

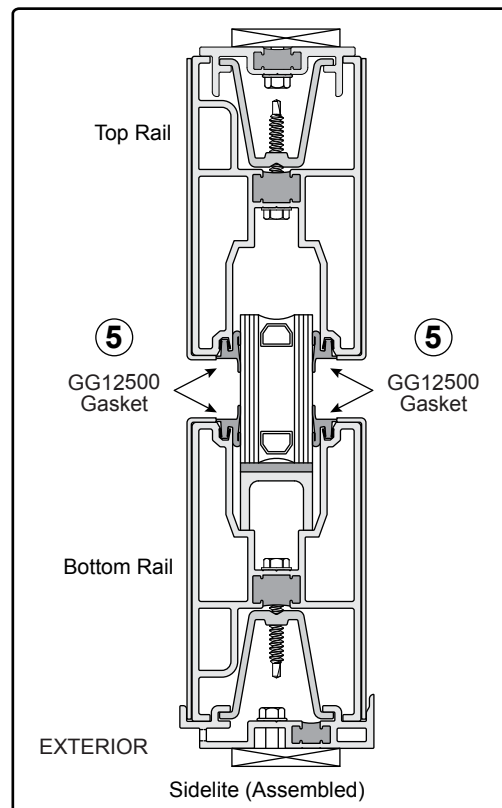

DOORWAY JAMB AT WALL INSTALLATION

Follow instruction on Page 10 to install Doorway Jamb at wall, and then Pages 11 - 13 to prepare and hang door. Install remaining clad as shown on Page 22 and then finish installation on Page 33.

CLAD INSTALLATION

Remove liner from VHB Tape and apply Cladding. Roll On Pressure = 15 Pounds Per Linear Inch.

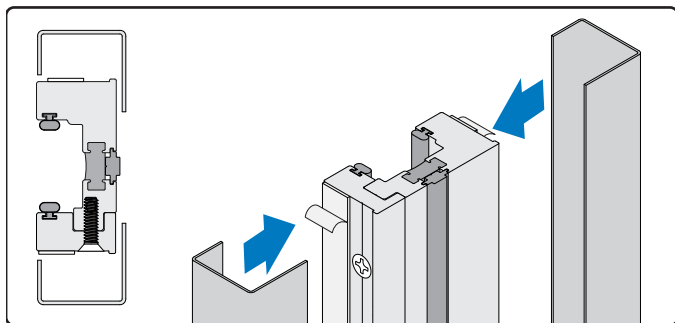

Doorway Jamb at Sidelite

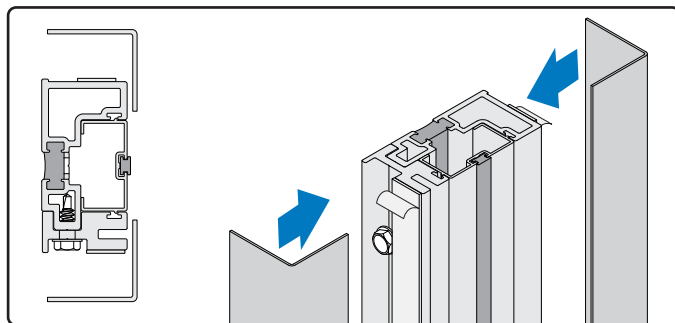

Doorway Jamb at Wall

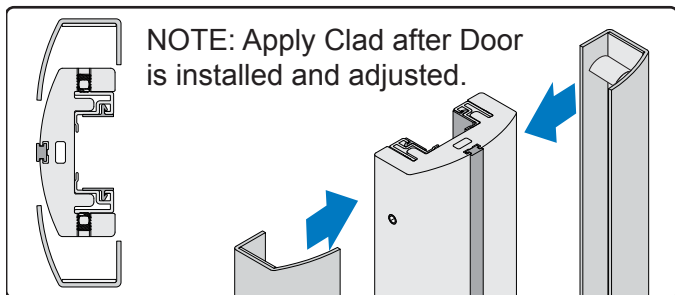

Center Pivot Door Stile

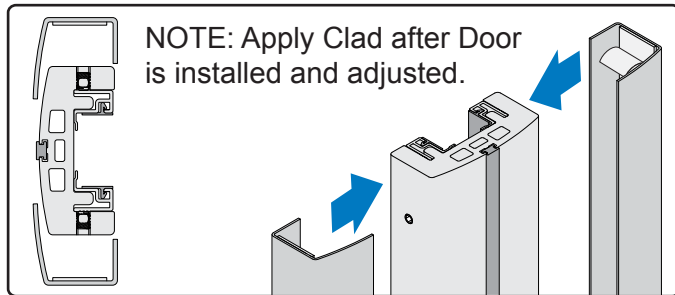

Offset Pivot Door Stile



Door Header

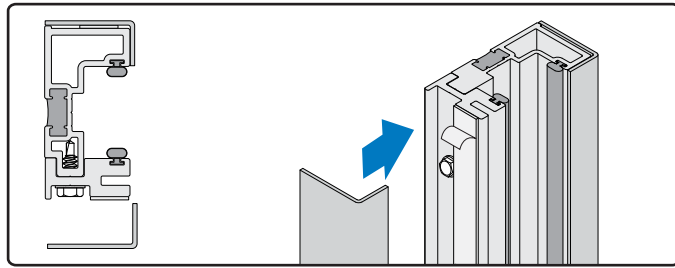

Wall Jamb

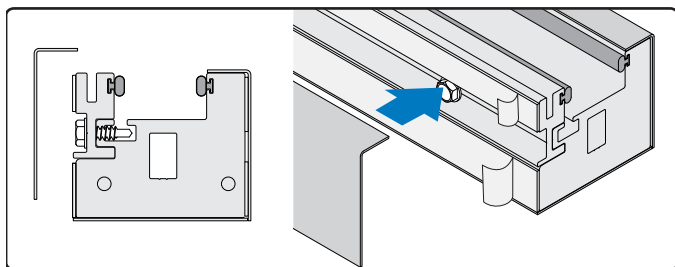

Transom Header

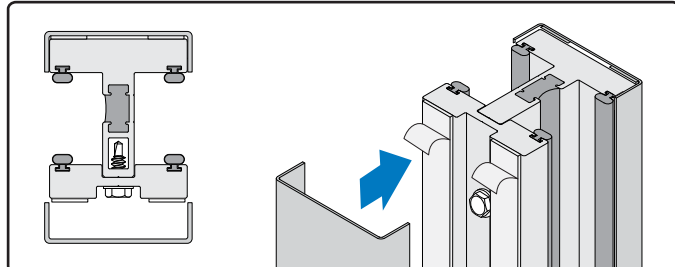

Intermediate Mullion

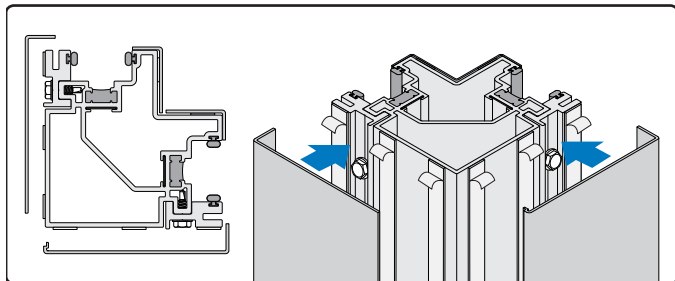

90° Inside Corner

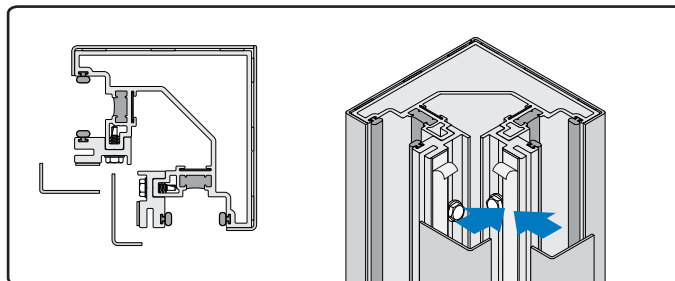

90° Outside Corner

TRANSOM DOOR INSTALLATION

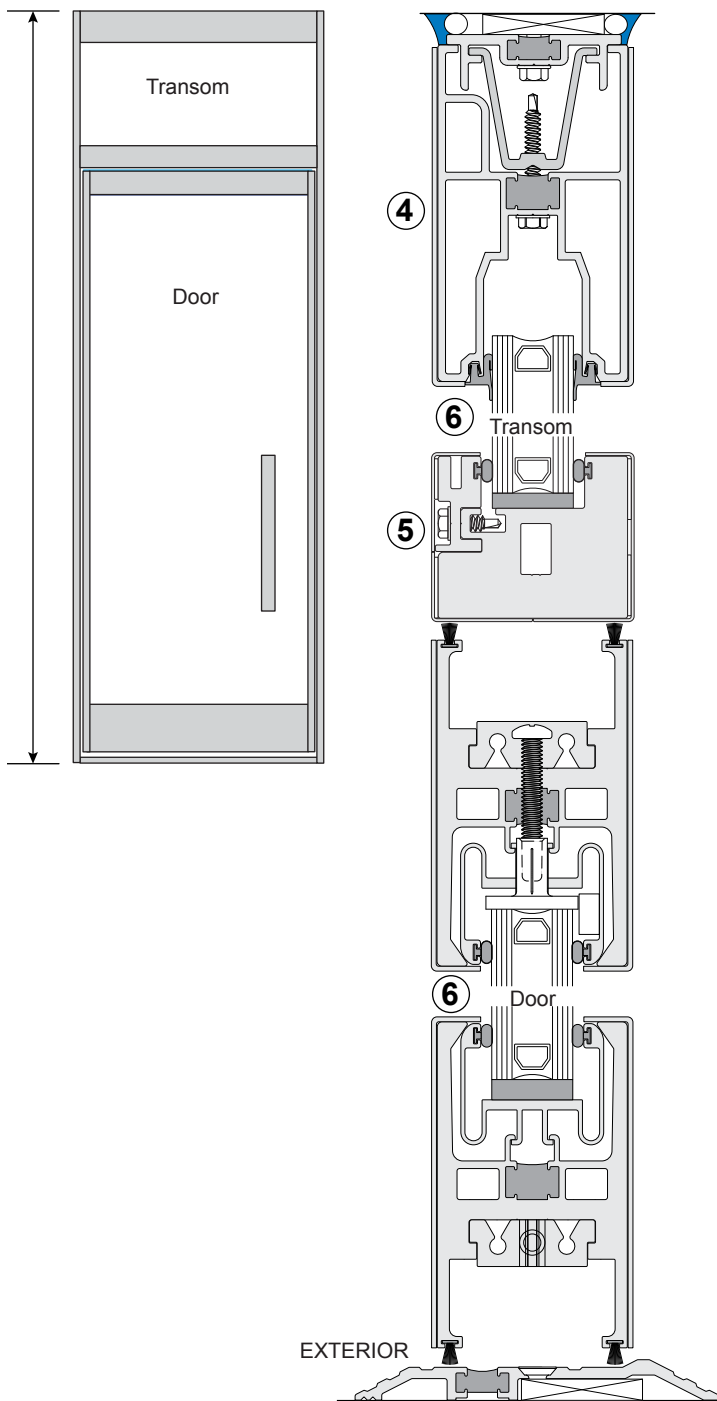

Transom Door Installation Order		
①	Threshold	Page 9
②	Top Anchor	Page 17
③	Transom Doorway Jamb	Page 24
④	Transom Top Rail	Page 25
⑤	Transom Header	Page 25
⑥	Transom Glass	Page 26
⑦	Clad	Page 22
⑧	Door	Page 11 - 13
⑨	Finishing and Sealing	Page 33
⑩		
⑪		

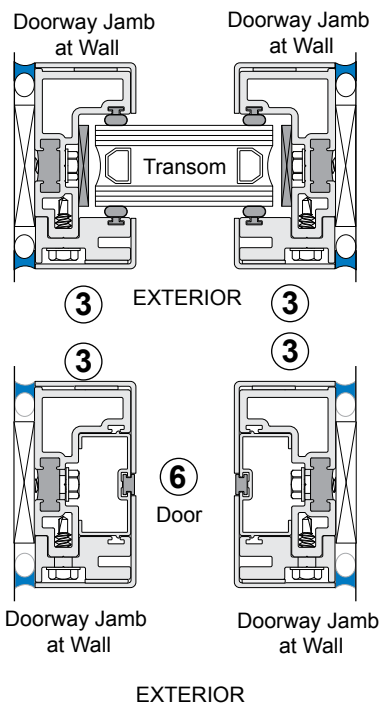

Begin on Page 7 for Site Preparation. Follow instructions to install Door with Sidelite beginning on Page 9 for Threshold Installation and continue on Pages 15 - 21.

NOTE: Skip Step 1 on Page 16 and instead of the Door Header, install a Top Anchor above the Threshold.

TRANSOM JAMB INSTALLATION

- ① Install Clad for Doorway Jamb.

NOTE: Clad is notched at top for Transom.

- ② Fasten Transom Jamb Main Body to Doorway Jamb at hole locations with 10-24 x 3/4" PHMS.

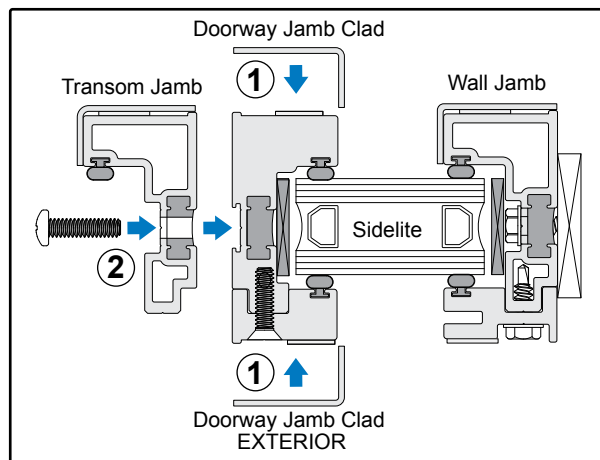
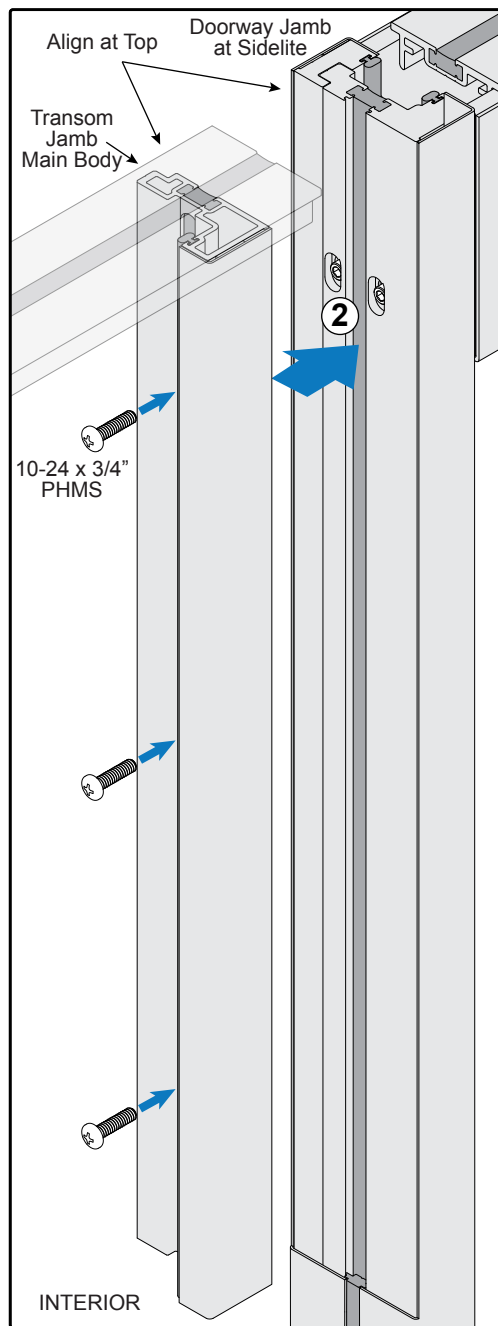
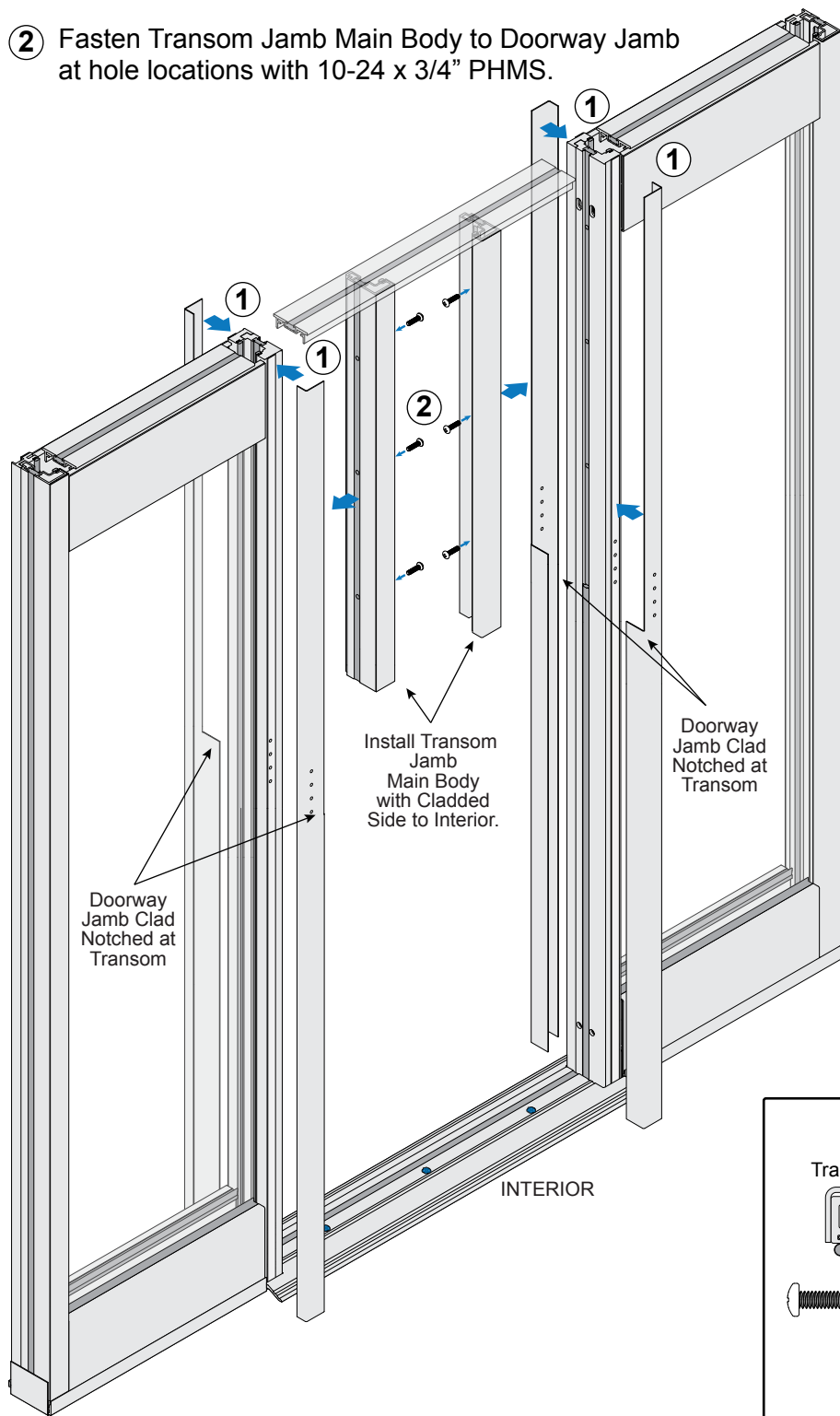

TRANSOM TOP RAIL INSTALLATION

① Align Fastening Clips with holes in Transom Top Rail and secure.

TRANSOM HEADER INSTALLATION

② Attach Left and Right Support Fin Bottom Fittings to Transom Header Main Body.

NOTE: Transom Header notched at ends to accept Support Fins. Support Fins installed on interior.

③ Fit Transom Header between Doorway Jambes with top of Transom Header butt against bottom of Transom Jambes.

④ Match holes on Doorway Jambes with Bottom Support Fin holes and secure.

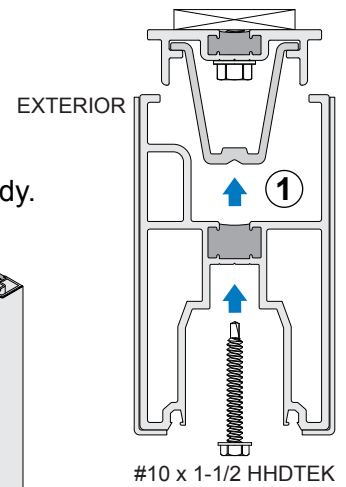

#10 x 1-1/2 HHDEK

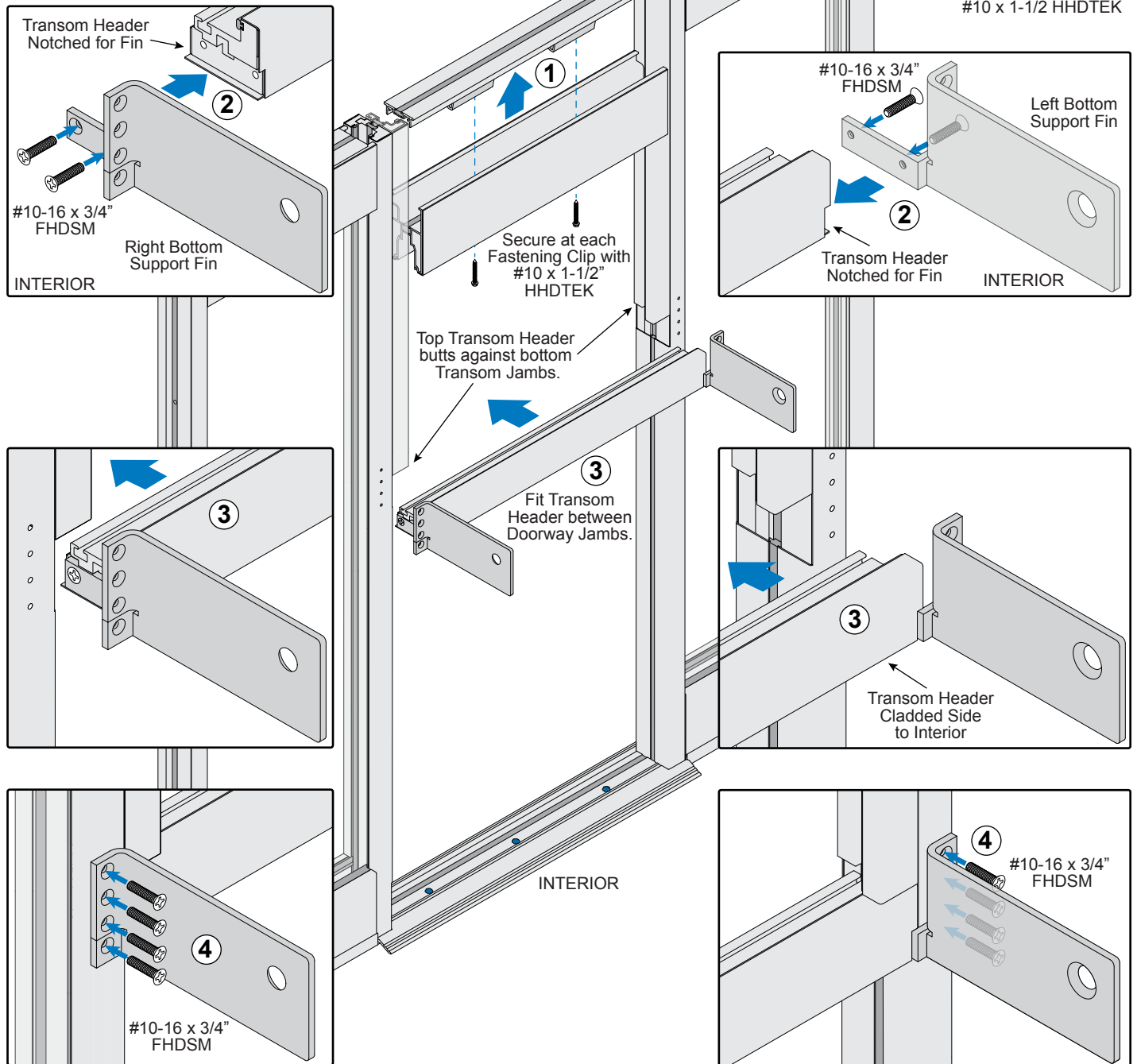

TRANSOM GLASS INSTALLATION

- ① Trim edges of the glass at face and sides with a sharp utility knife to remove any excess Silicone Sealant.
- ② Place Setting Blocks 4" from each end of Transom Header and Edge Blocks at quarter points inside Transom Jamb Vertical pocket.
- ③ Lift and set glass into pocket. Center.

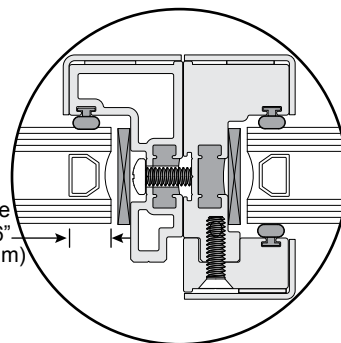
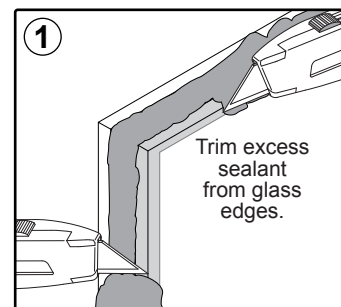
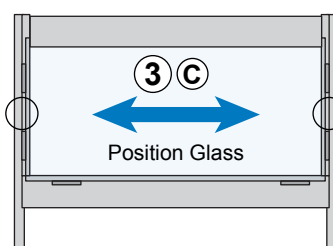
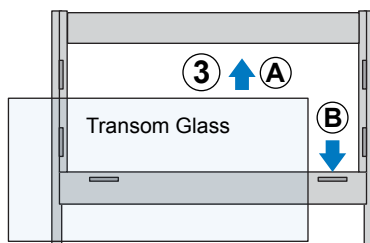
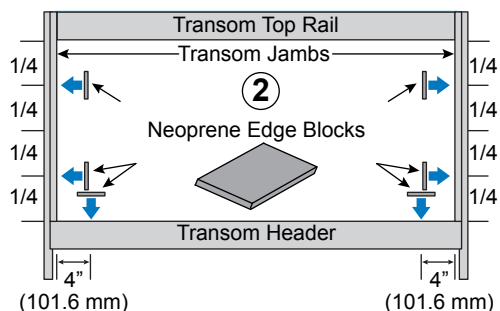

- ④ Roll NP238 Gaskets into both sides of Top Rail with a CRL Vinyl Roller.
- ⑤ Install Removable Stop for Transom Header and secure with screws at all predrilled hole locations.
- ⑥ Install Removable Stops for Transom Jamb and secure with screws at all predrilled hole locations.

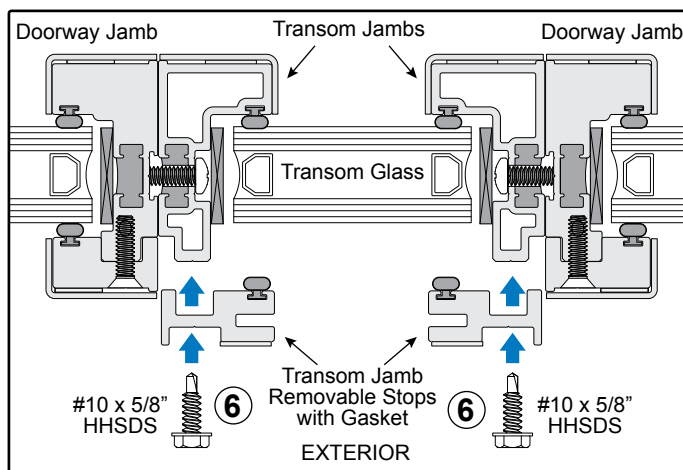
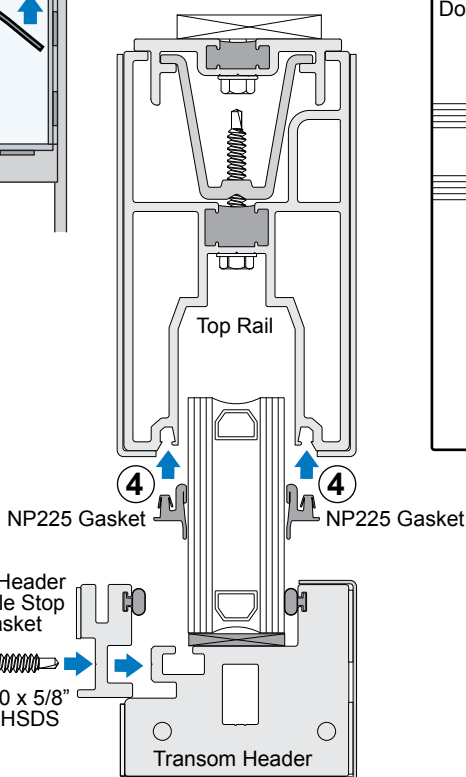
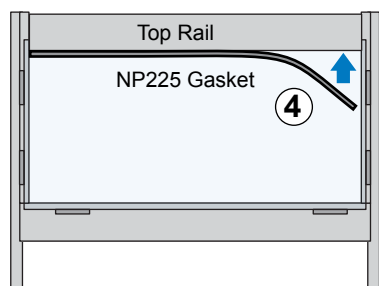

SUPPORT FIN INSTALLATION

NOTE: Go to Page 22 to install Clad before proceeding with the Support Fin Installation.

- ① Position Mounting Bracket flush against cladded Doorway Jamb. Secure to ceiling.
- ② Place Gasket on Bottom Support Fin.
- ③ Fit Nylon Grommets in holes in Glass Fin and slide into Mounting Bracket.
- ④ Secure Fin to Mounting Bracket with Sex Bolts and Sex Bolt Shanks.

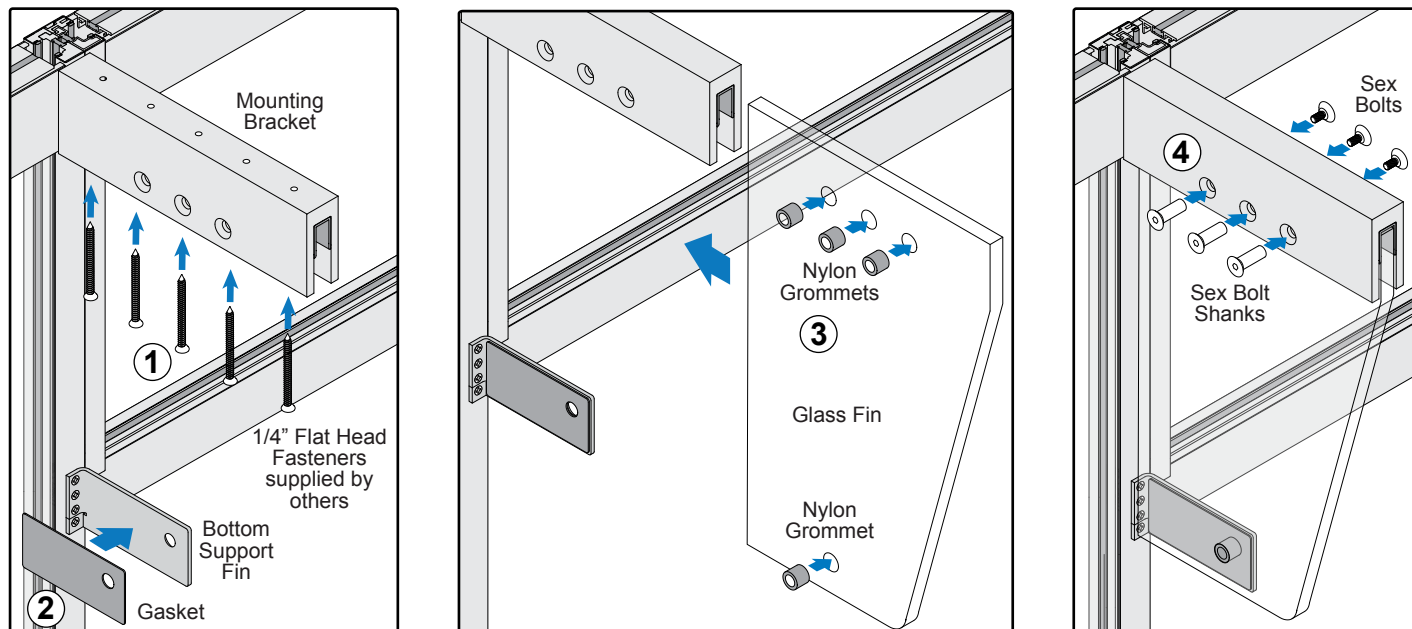

- ⑤ Position Clamping Plate and Gasket with Bottom Support Fin.
- ⑥ Secure with Sex Bolt and Sex Bolt Shank.
- ⑦ Install Fitting Covers to both sides of Mounting Brackets and Bottom Support Fins.

NOTE: Remove liner from VHB Tape to apply Fitting Covers.

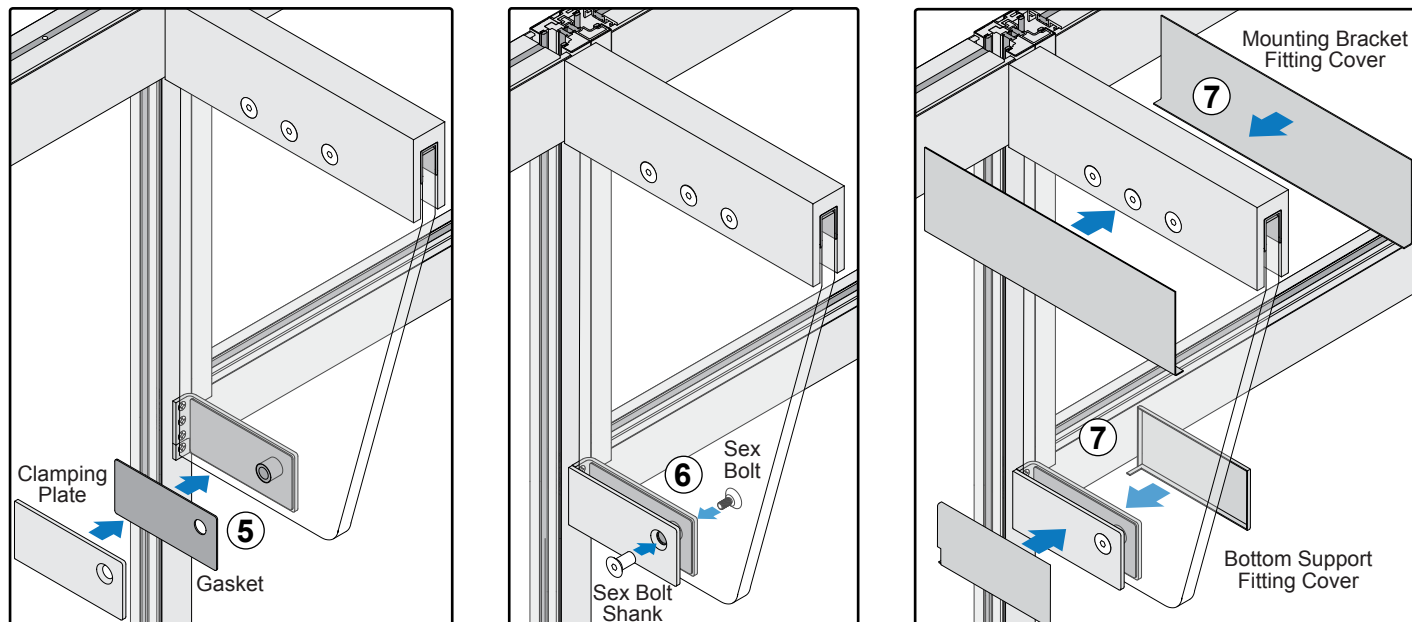

FIXED LITE INSTALLATION

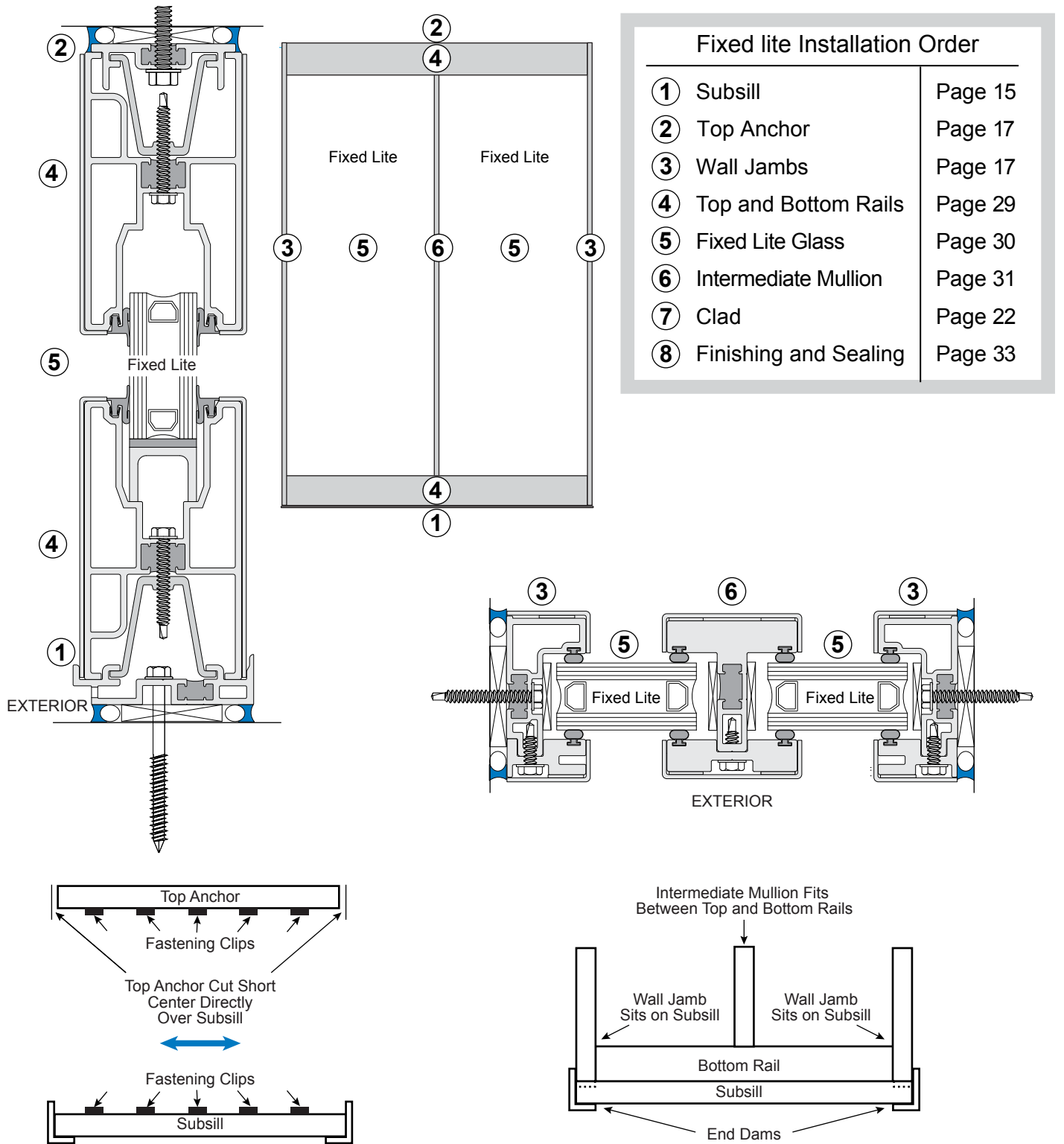

Begin with instructions on Page 7 for Site Preparation. Then install Subsill as shown on Page 15 and center Top Anchor above it as shown on Page 17. (Top Anchor is cut 1/2" (12.7 mm) short.) Continue with Wall Jamb Installation on Page 17.

FIXED LITE TOP AND BOTTOM RAIL INSTALLATION

- ① Attach Vertical Shear Clips at Intermediate Mullion position on Top and Bottom Rails.
- ② Position Fastening Clips above holes in Top and Bottom Rails and secure.

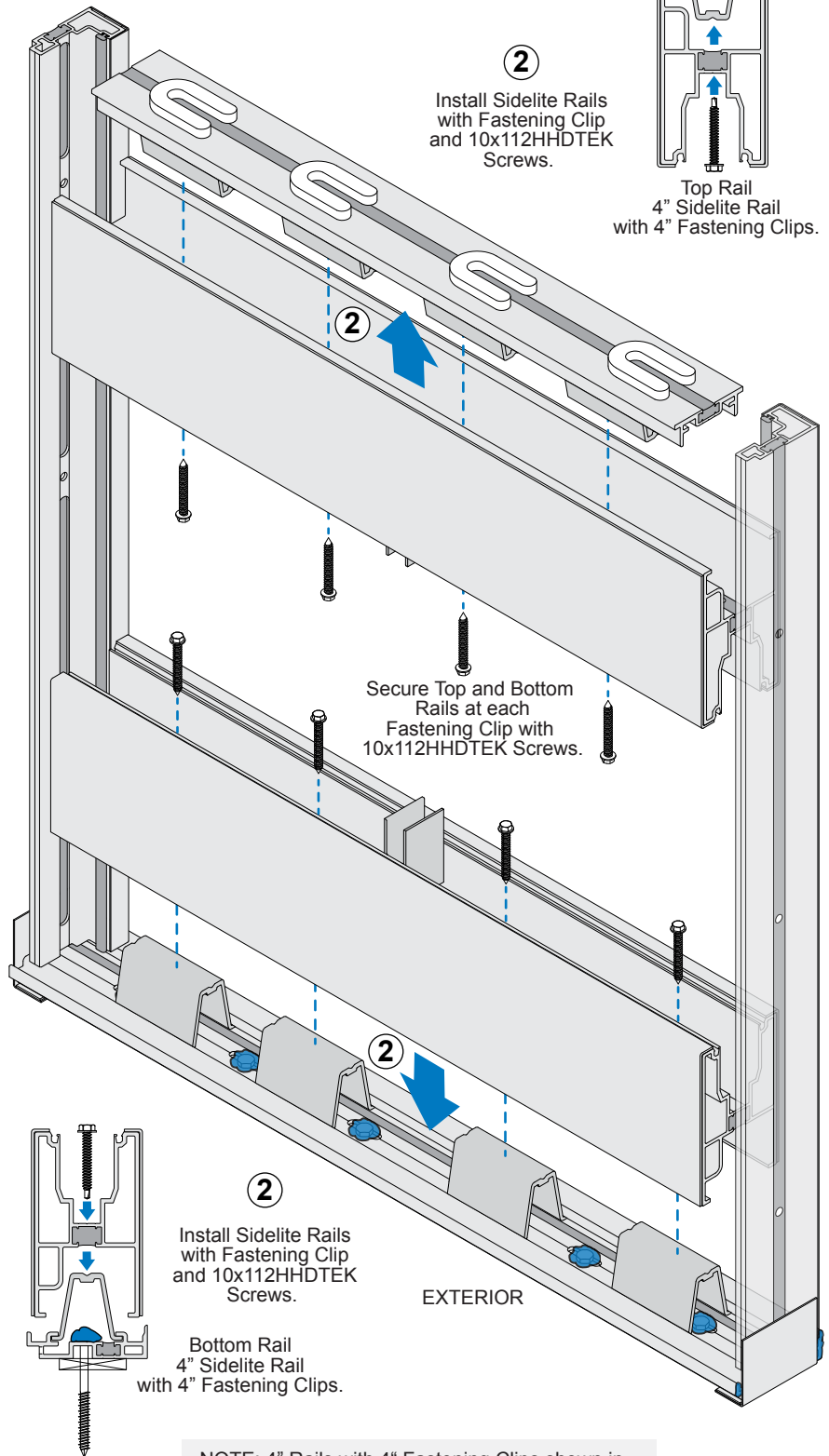
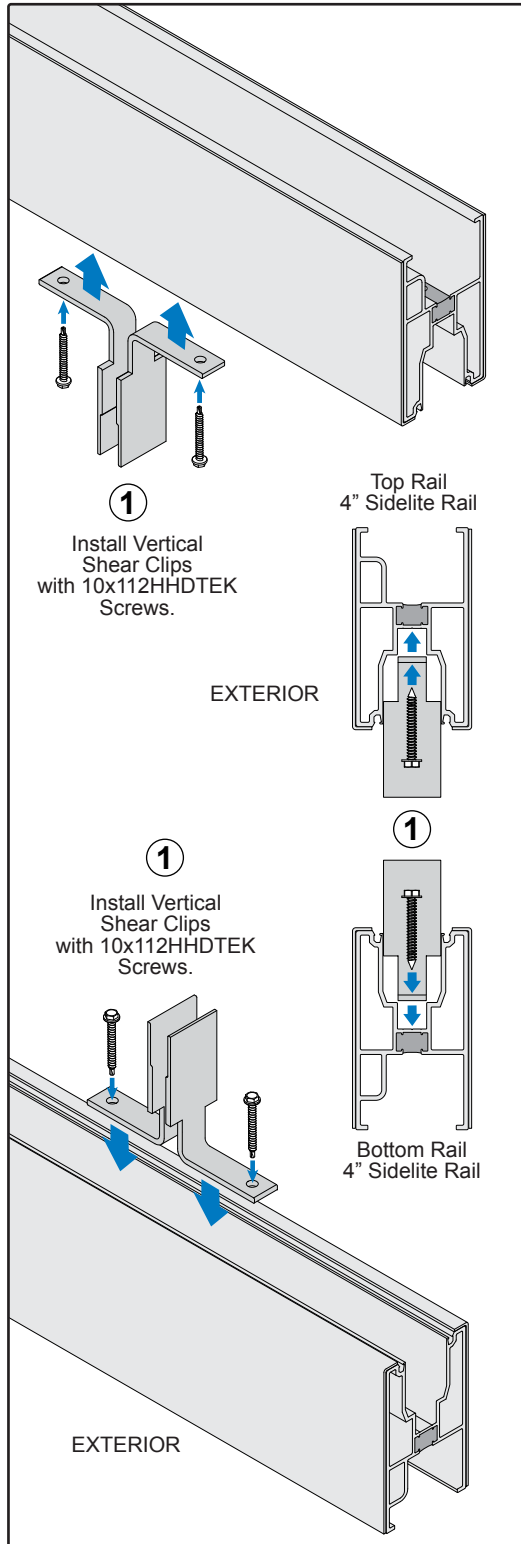

NOTE: 4" Rails with 4" Fastening Clips shown in illustrations. Use 10" Fastening Clip with 10" Rails.

FIXED LITE GLASS INSTALLATION

- 1 Trim edges of the glass at face and sides with a sharp utility knife to remove any excess Silicone Sealant.
- 2 Place Setting Blocks at quarter points in each section of Bottom Rail and Edge Blocks at quarter points inside Wall Jamb pocket.

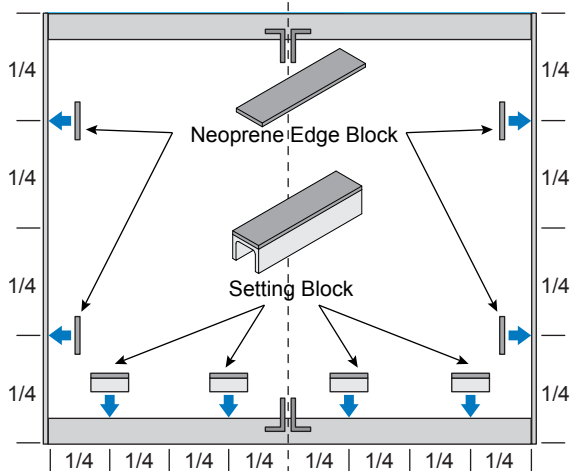
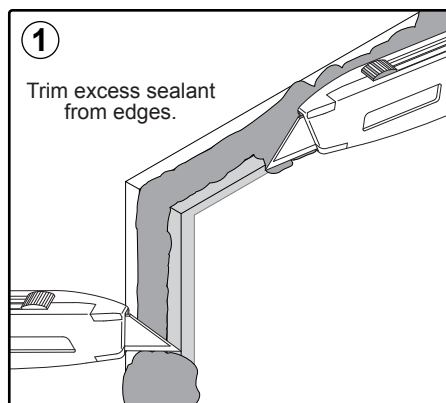

NOTE: Setting Blocks are packed loose with Sidelite Rails.

- 3 Lift and set each glass panel into pocket and center.

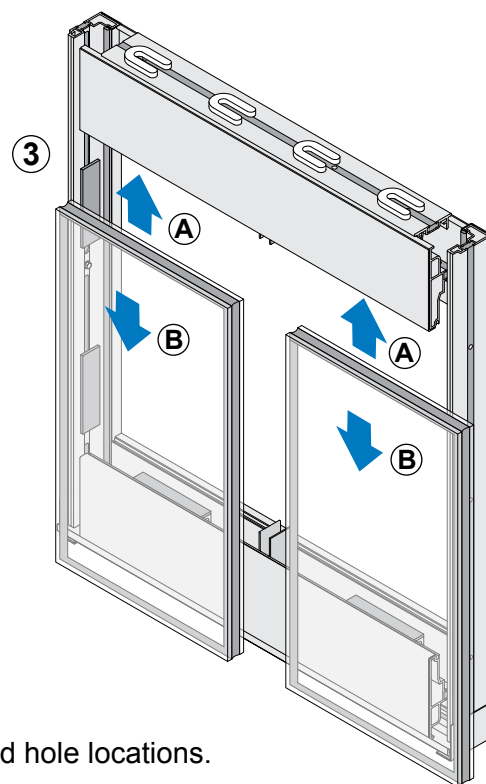
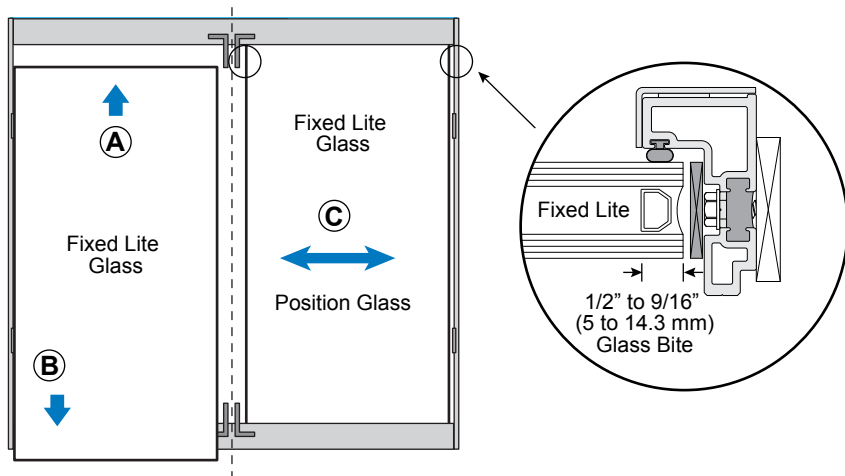

- 4 Secure Removable Stop to Wall Jamb Main Body at all predrilled hole locations.

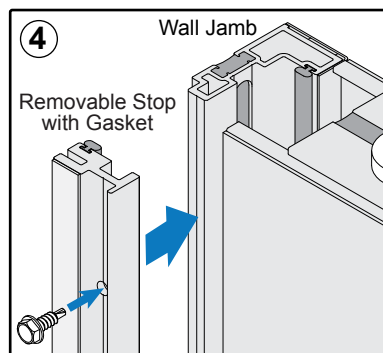
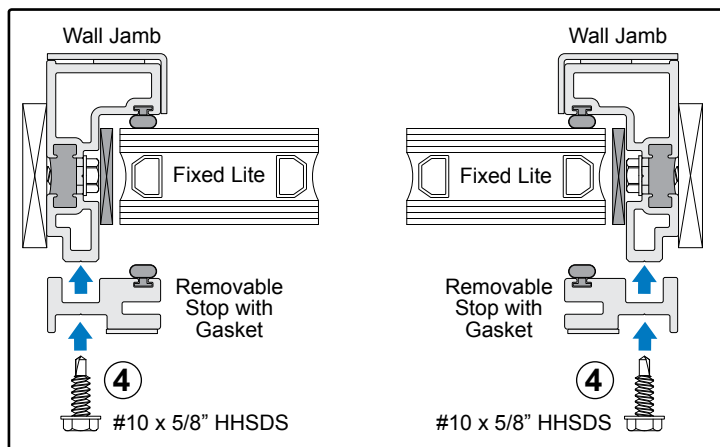

INTERMEDIATE VERTICAL MULLION INSTALLATION

- ① Fit Vertical Mullion Main Body between Vertical Shear Clips.
- ② Place Edge Blocks at quarter points on both sides of Vertical Mullion.
- ③ Install Removable Stop with screws at all predrilled hole locations.
- ④ Roll NP238 Gaskets into both sides of Top and Bottom Rails.

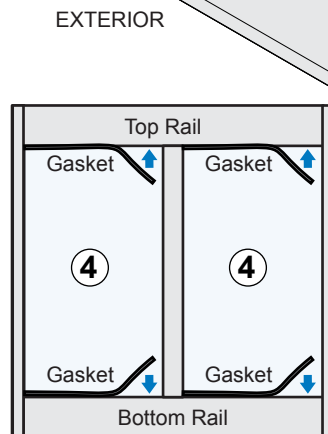
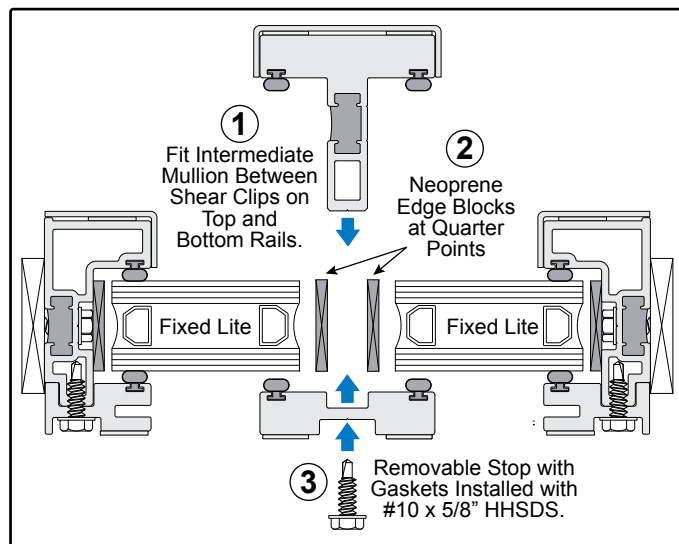
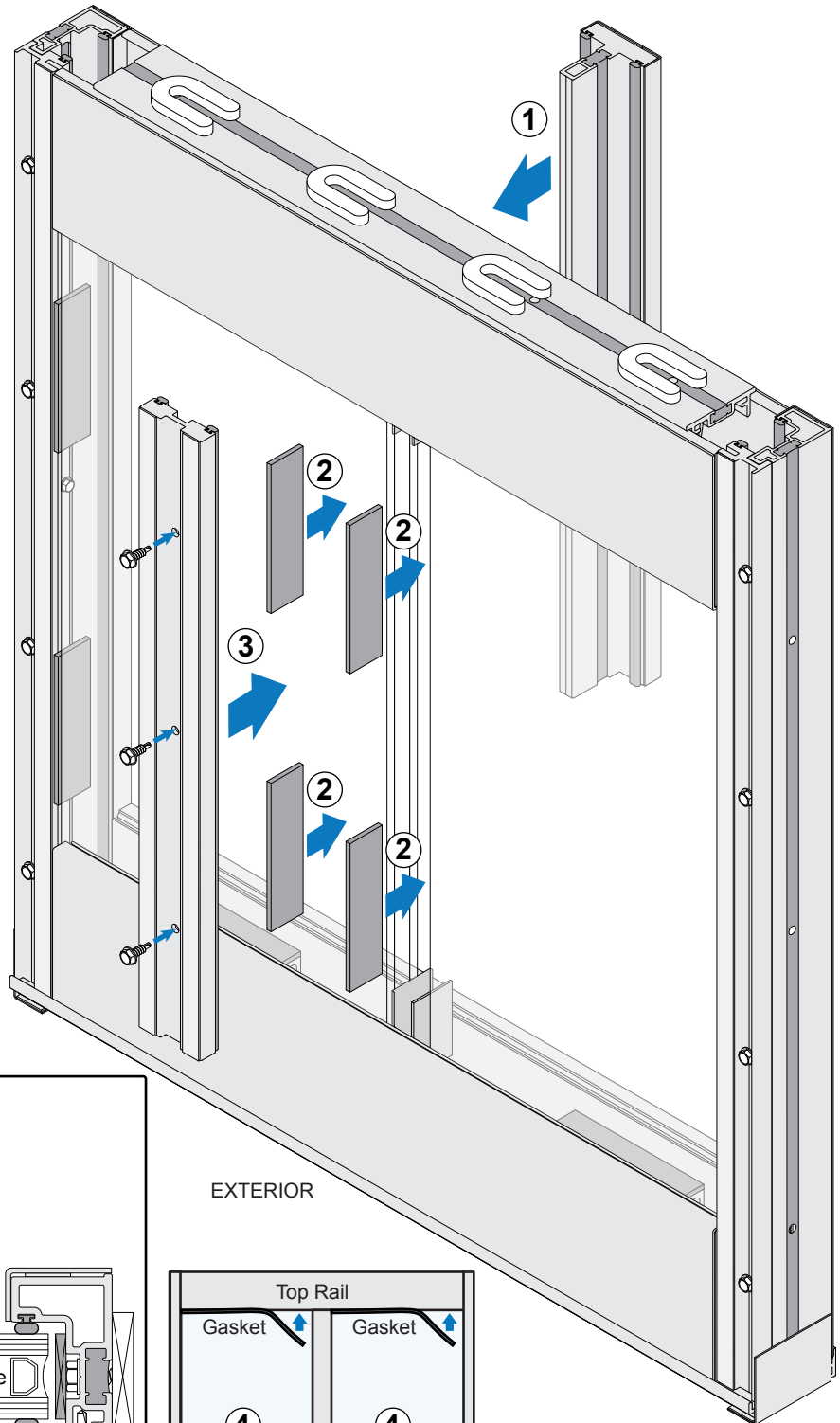
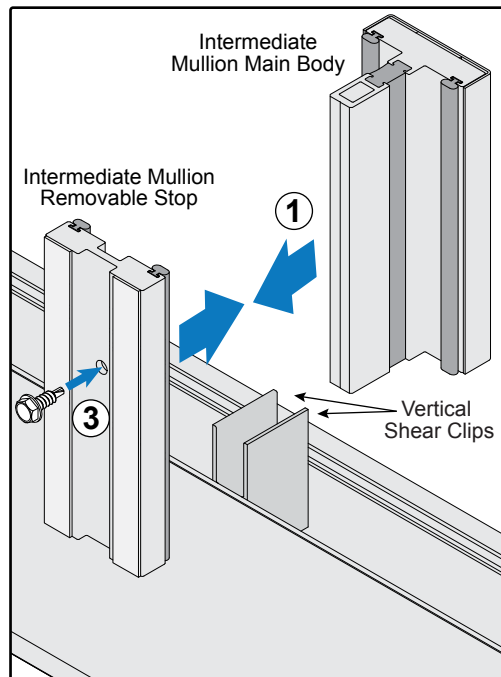

Roll Gaskets at each Fixed Lite Interior and Exterior Top and Bottom Rail with CRL Vinyl Roller.

- ⑤ Install clad as shown on Page 22 and then finish installation on Page 33.

90° INSIDE AND OUTSIDE CORNER INSTALLATION

1. Install Mitered Subsill and Top Anchor above.
2. Install Corner Main Body and Wall or Doorway Jambs on either side of it.

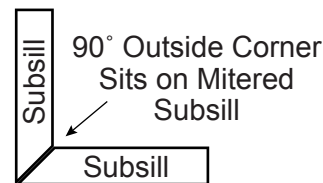
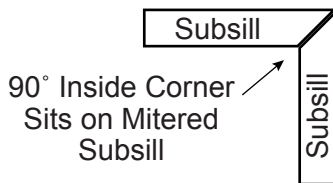
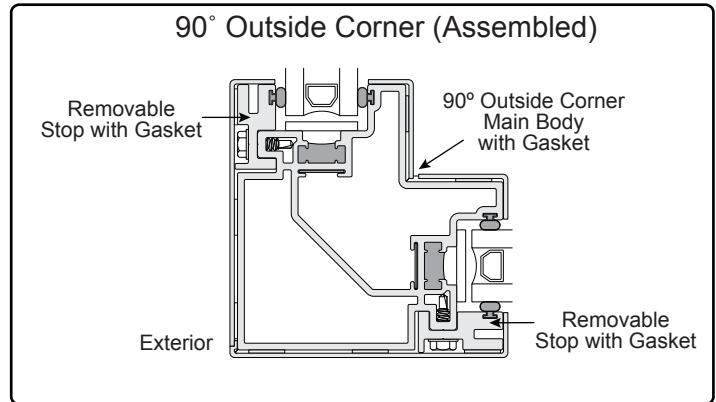
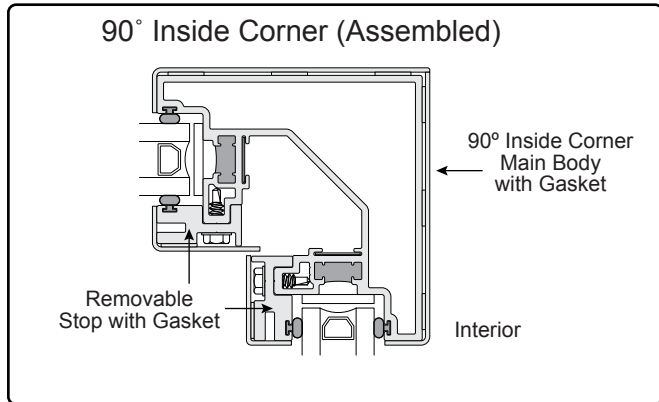

3. Install Corner Shear Clip into ends of Top and Bottom Rails next to Corner.

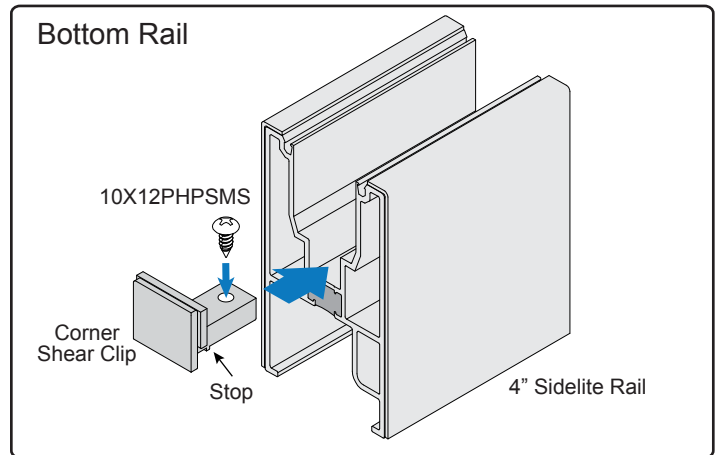
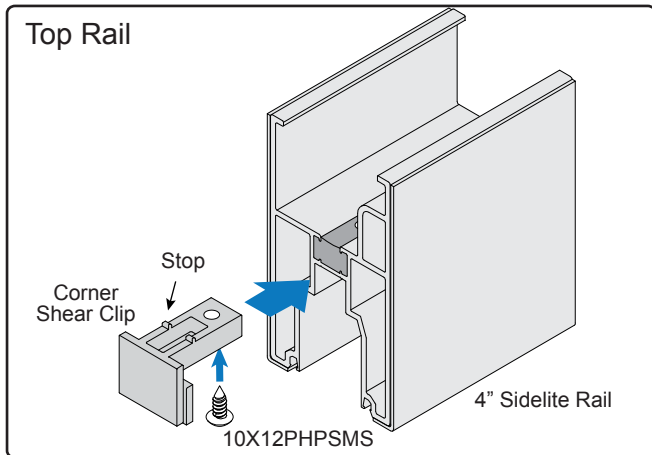

4. Prepare and install glass panels. Secure with Removable Stops.

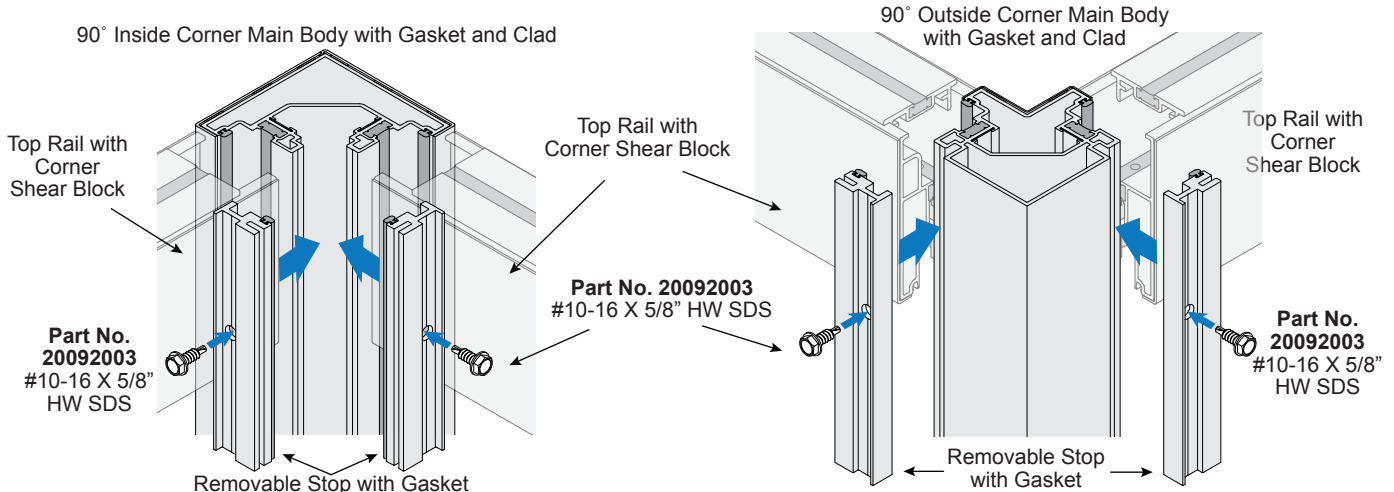

5. See Page 22 for Clad Installation.

PERIMETER SEALING

1. Seal around Doorway Jamb at Threshold.

Seal around Doorway Jamb at notched Threshold with **Cat. No. 33S Clear Silicone**.

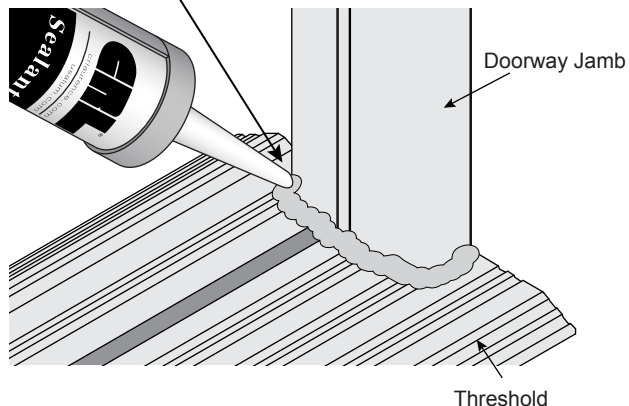

2. Seal joints between Bottom Rail and Subsill inside and outside.

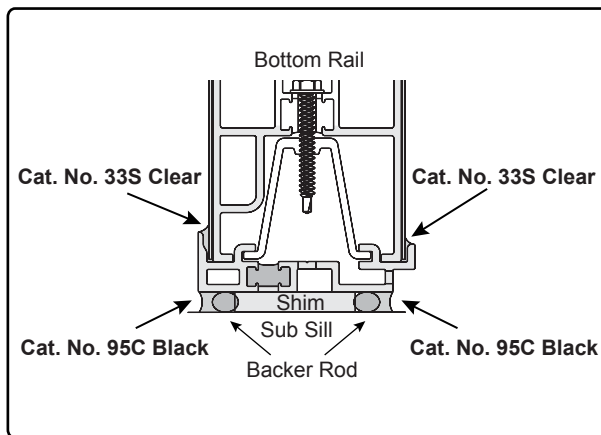

3. Install Backer Rod and seal perimeter with **Cat. No. 95C Silicone Sealant** at all shimmed areas inside and outside.

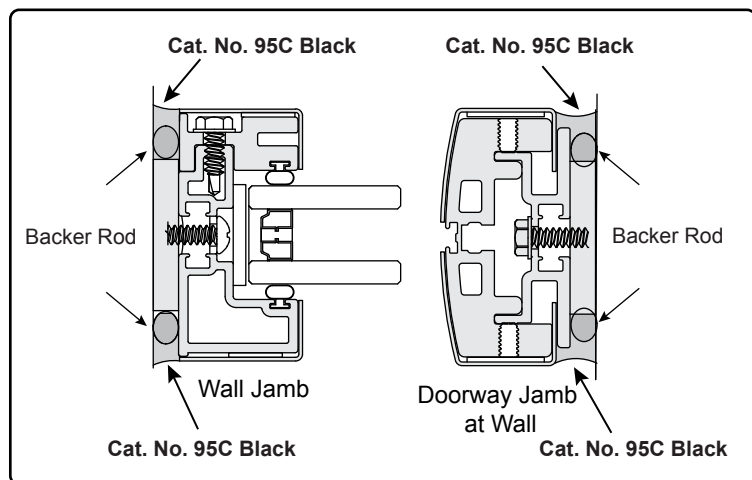

4. Seal interior perimeter at all verticals 2" (203 mm) up from ground where they meet Bottom Rails.

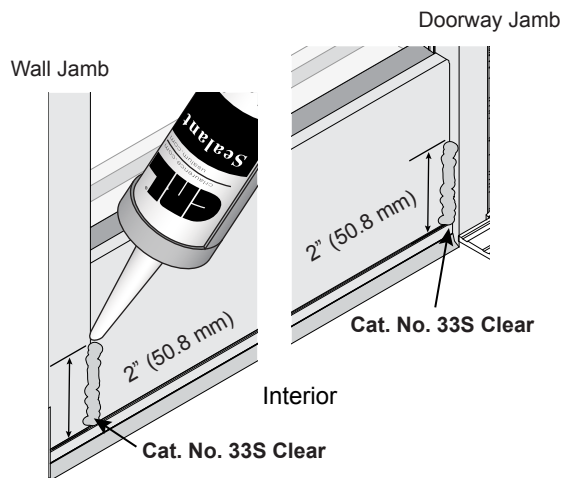

5. Seal outside bottom corners where all verticals meet Bottom Rails.

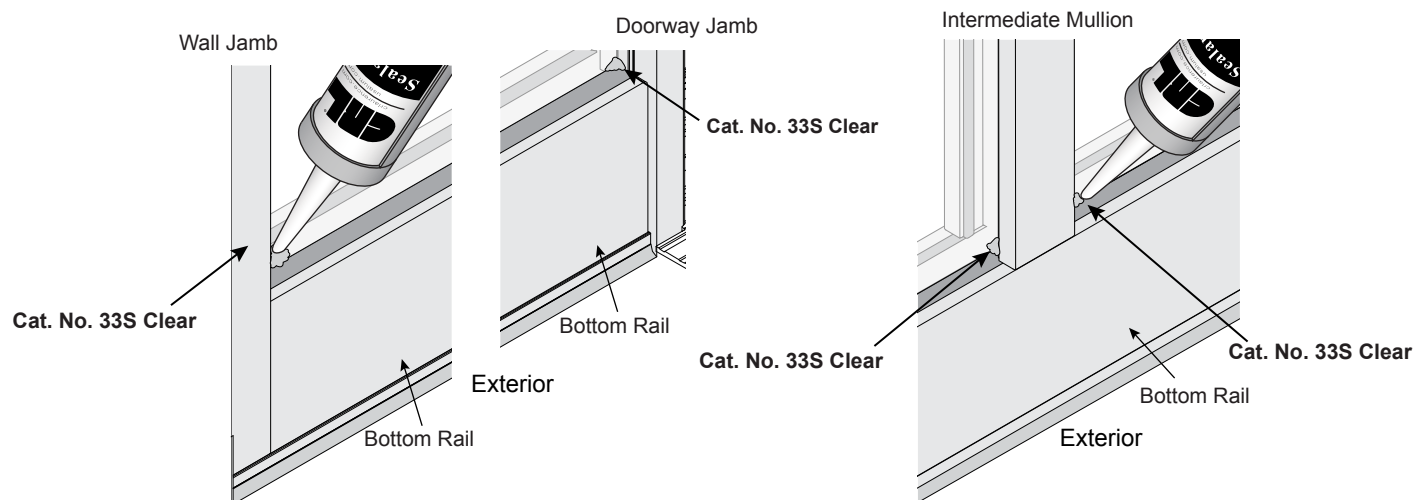

GLASS REPLACEMENT FOR DOORS

REMOVE DAMAGED GLASS

- ① Support door on sturdy sawhorses. Remove door handles and panic or exit devices and store in a safe place.

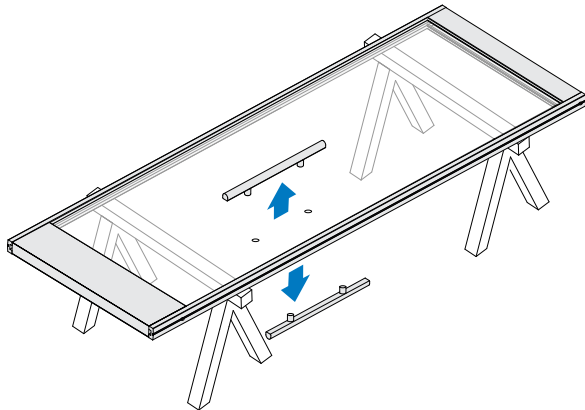

- ② Remove Cladding from both sides of Vertical Stiles.

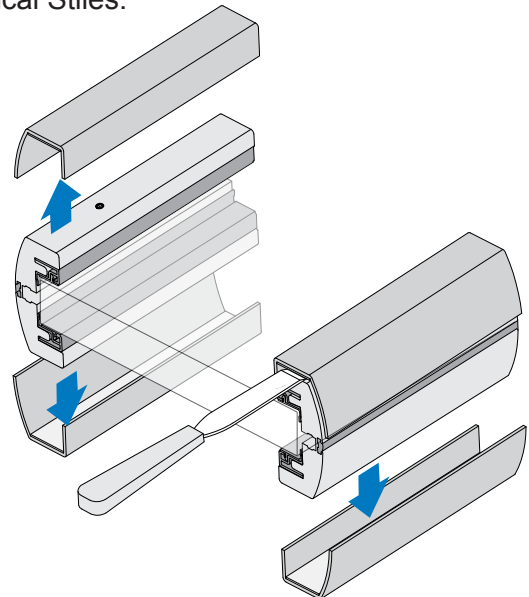

- ③ Loosen Set Screws on both sides of Vertical Stiles.

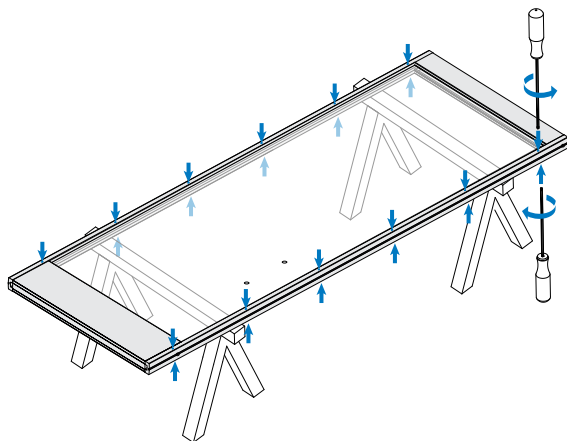

- ④ Back out Clamping Screws on Top and Bottom Rails.

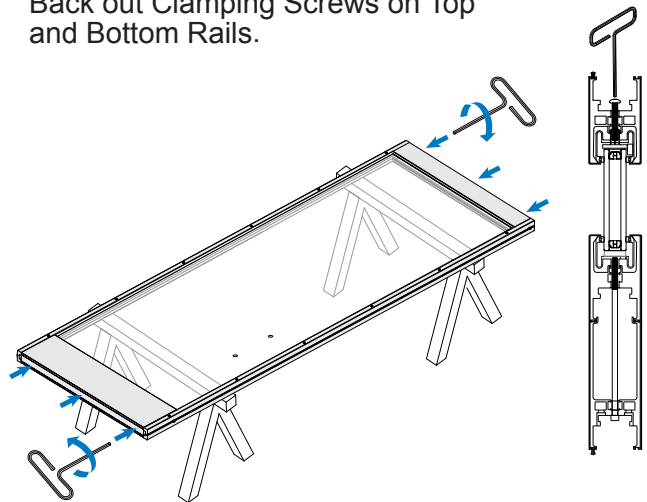

- ⑤ Remove Socket Head Cap Screws from each corner.

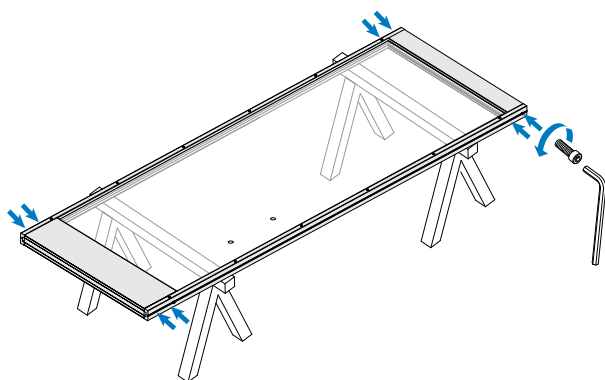

- ⑥ Remove Vertical Stiles and Top and Bottom Rails. If Gaskets are not in good condition, remove them. If replacing Top and Bottom Rail Cladding, do so now.

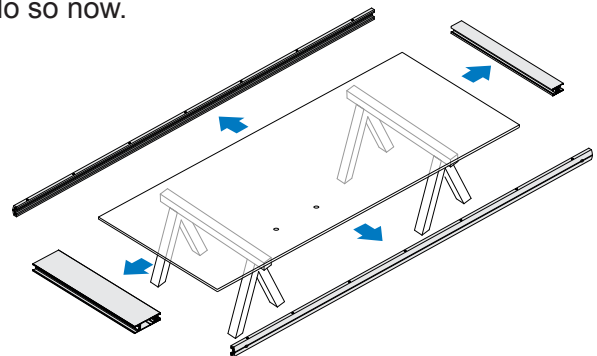

INSTALL REPLACEMENT GLASS

- ① Verify replacement glass size and mounting hole placement for handles.

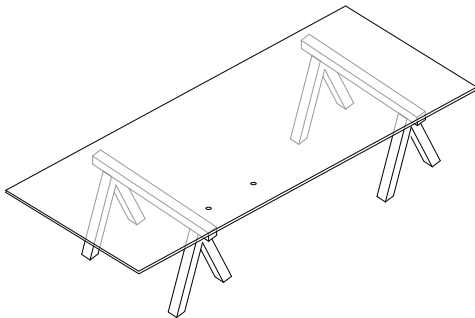

- ② Place Top and Bottom Rails and tighten Clamping Screws. NOTE: Ensure Rails are properly supported until secured to Vertical Stiles.

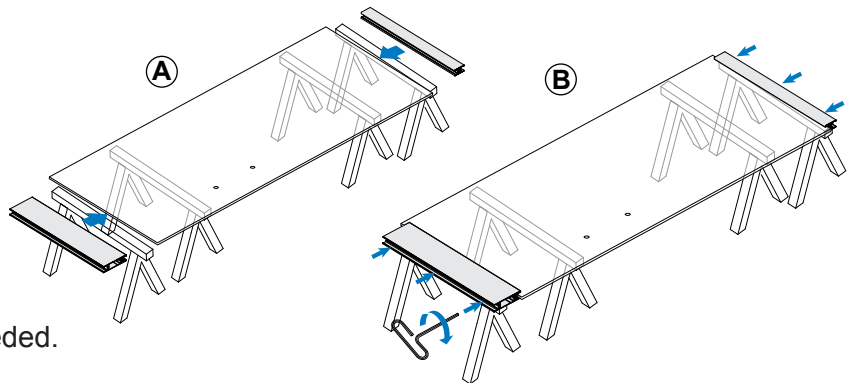

- ③ Replace Gaskets in Vertical Stiles if needed.

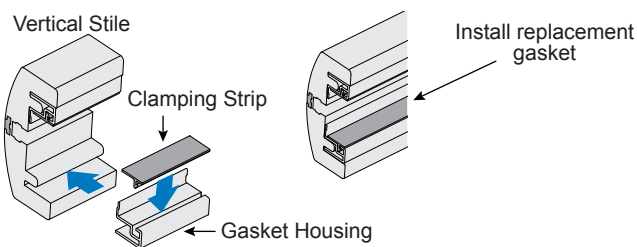

NOTE: The Vertical Stiles may be installed as three separate pieces. First apply the Clamping Strip to the glass, then fit the Gasket Housing over it and finally slide the Vertical Stile over it. This works well with oversized glass thickness.

- ④ Spray glass edges with Cat. No. 1973 to prevent Gaskets from binding and install Vertical Stiles.

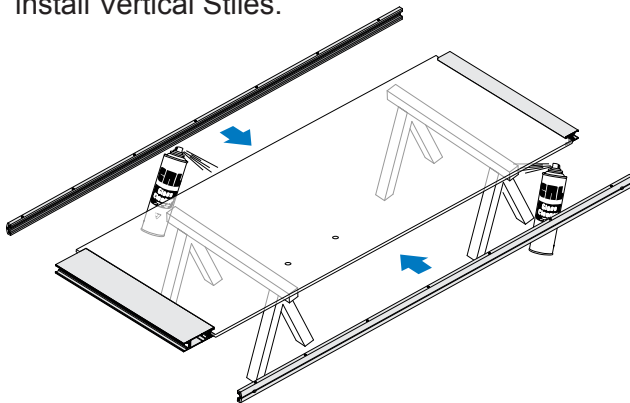

- ⑤ Apply Blue Loctite to Socket Head Cap Screws and fasten Vertical Stiles to Top and Bottom Rails.

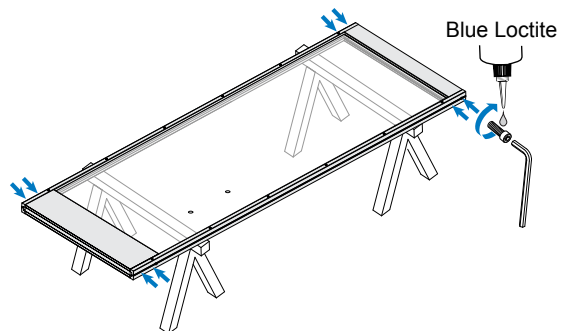

- ⑥ Push frame at bottom to ensure Setting Block is in contact with glass. Ensure Bottom Rail is tight against glass and Vertical Stiles are straight.

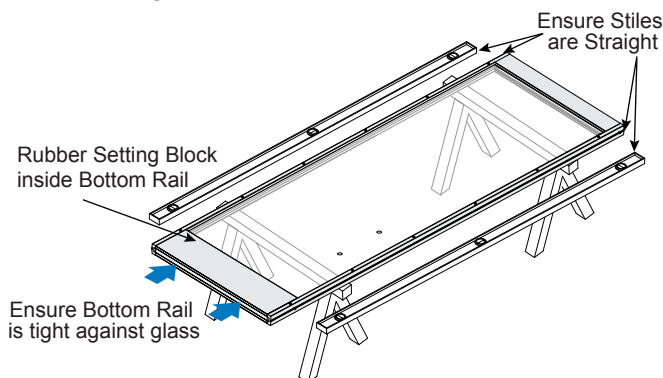

- ⑦ Tighten Set Screws evenly on Hinge Side of the Vertical Stiles. Torque 1/8 turn past tight.

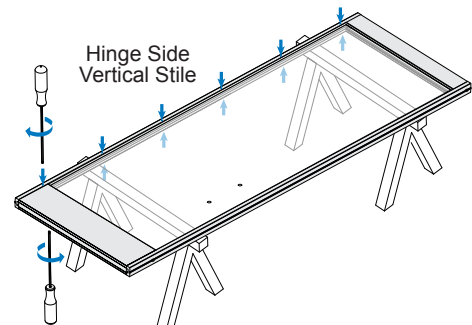

INSTALL REPLACEMENT GLASS (CONTINUED)

- 8 Turn Adjuster in Top Rail on Handle Side clockwise until it contacts glass. Measure diagonally to corners. If needed, turn Adjuster again to raise corner a maximum of 1/8" (3.2 mm) until door is square.

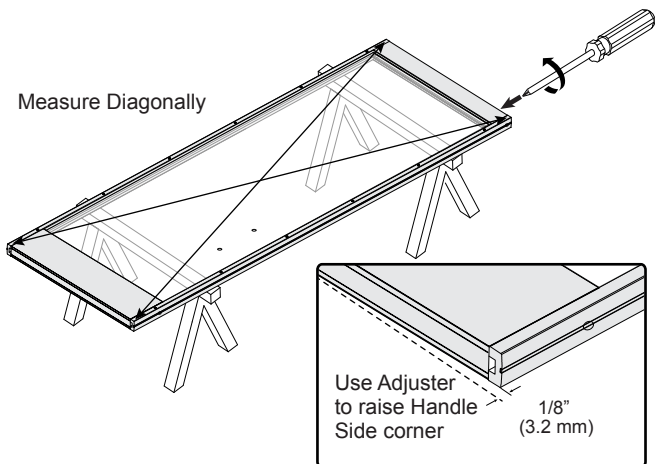

- 9 Tighten Set Screws evenly on Handle Side of the Vertical Stiles. Torque 1/8 turn past tight.

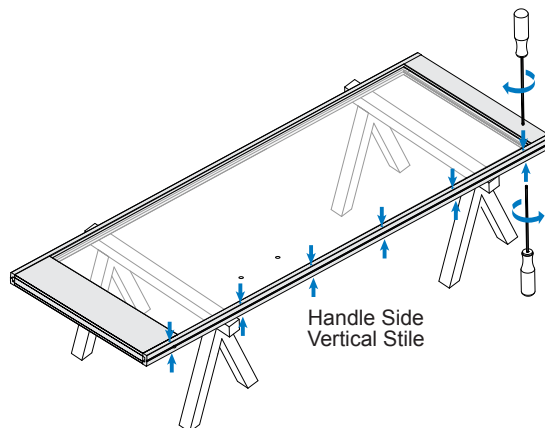

- 10 Measure between Vertical Stiles near Bottom Rail and again at middle to ensure Stiles are straight.

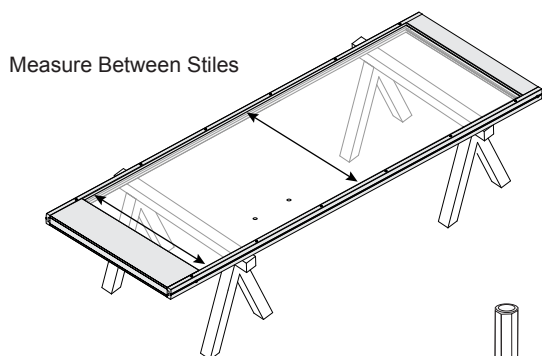

- 11 Apply Blue Loctite on all attachment fasteners and install door handles.

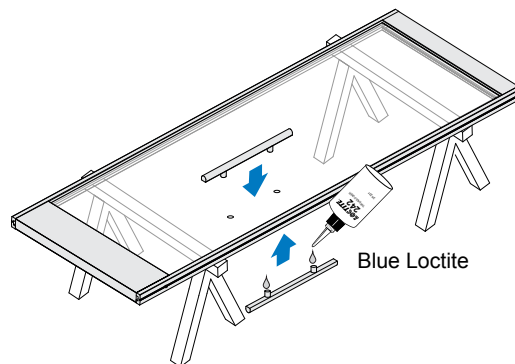

- 12 Follow instructions on Page 13 to install and adjust door.

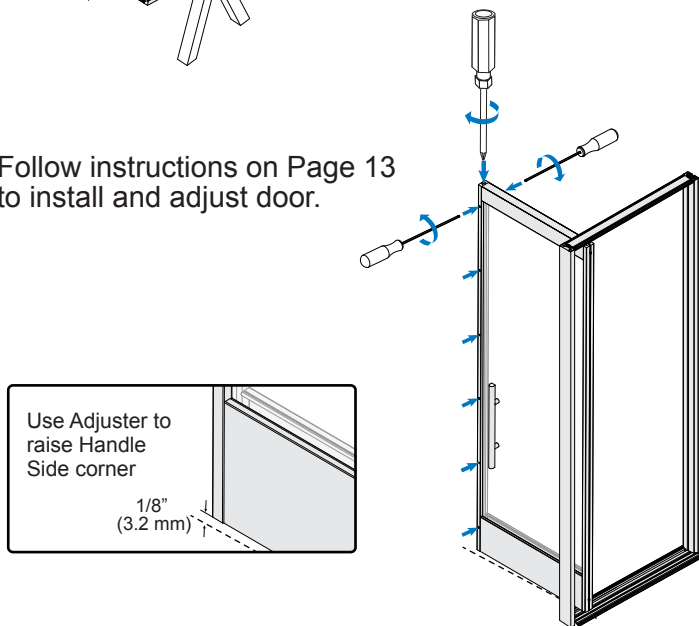

- 13 Remove liner from VHS Tape and apply Cladding to Vertical Stiles.

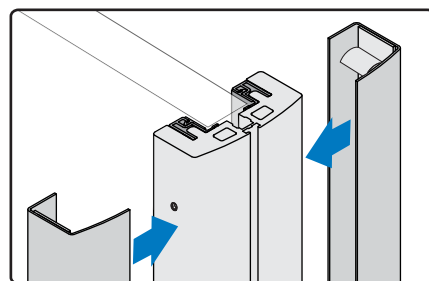

Roll On Pressure = 15 Pounds Per Linear Inch

NOTE: If Handle Side sags, loosen Set Screws and turn Adjuster to raise. Then tighten Set Screws.