

INSTALLATION INSTRUCTIONS

ArcticFront™ SERIES 375-T High Performance Thermal Door

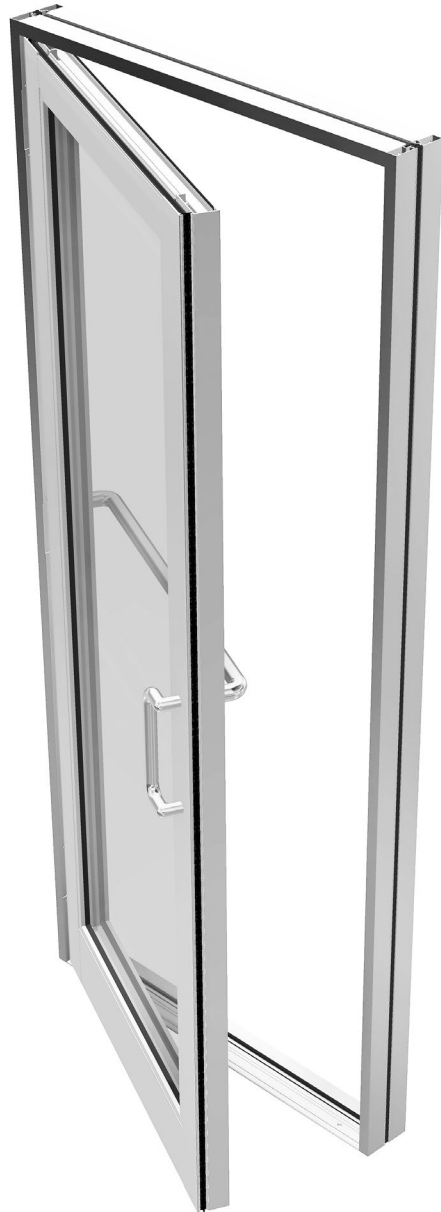

Phone: (800) 262-5151 • Fax: (866) 262-3299
crlaurence.com • usalum.com • crl-arch.com

11M0245_REV A_7-17-18

HANDLING, STORAGE, AND PROTECTION OF ALUMINUM

The following precautions are recommended to protect the material against damage. Following these precautions will help ensure early acceptance of your products and workmanship.

A. HANDLE CAREFULLY.

All aluminum materials at job site must be stored in a safe place, well removed from possible damage by other trades. Cardboard wrapped or paper interleaved materials must be kept dry.

B. CHECK ARRIVING MATERIALS.

Check for quantities and keep records of where various materials are stored.

C. KEEP MATERIALS AWAY FROM WATER, MUD, AND SPRAY.

Prevent cement, plaster or other materials from damaging the finish.

D. PROTECT THE MATERIALS AFTER ERECTION.

Protect erected frame with polyethylene or canvas splatter screen. Cement, plaster, terrazzo, other alkaline solutions, and acid based materials used to clean masonry are harmful to the finish. ***If any of these materials come in contact with the aluminum, IMMEDIATELY remove with water and mild soap.***

IMPORTANT: READ THIS MANUAL THOROUGHLY BEFORE BEGINNING INSTALLATION.

GENERAL INSTALLATION NOTES

Recommended Guidelines for All Installations:

- 1. REVIEW CONTRACT DOCUMENTS.** Check shop drawings, installation instructions, architectural drawings, and shipping lists to become thoroughly familiar with the project. The shop drawings take precedence and include specific details for the project. Note any ***field verified*** notes on the shop drawings prior to installing. The installation instructions are of a general nature and cover most conditions.
- 2. INSTALLATION.** All materials are to be installed plumb, level, and true.
- 3. BENCH MARKS.** All work should start from bench marks and/or column lines as established by the architectural drawings and the general contractor with guaranteed accuracy. Working from these datum points and lines determine:
 - a) The plane of the wall in reference to offset lines provided on each floor.
 - b) The finish floor lines in reference to bench marks on the outer building columns.
 - c) Mullion spacing from both ends of masonry opening to prevent dimensional build-up of daylight opening.
- 4. FIELD WELDING.** All field welding must be adequately shielded to avoid any splatter on glass or aluminum. Results will be unsightly and/or structurally unsound. Advise general contractor and other trades accordingly. All field welds of steel anchors must receive touch-up paint (zinc chromate) to avoid rust.
- 5. SURROUNDING CONDITIONS.** Make certain that construction which will receive your materials is in accordance with the contract documents. If not, notify the general contractor in writing and resolve differences before proceeding with work.
- 6. ISOLATION OF ALUMINUM.** Aluminum to be placed in direct contact with uncured masonry or incompatible materials should be isolated with a heavy coat of zinc chromate or bituminous paint.
- 7. SEALANTS.** Sealants must be compatible with all materials with which they have contact, including other sealant surfaces. Consult with sealant manufacturer for recommendations relative to joint size, shelf life, compatibility, cleaning, priming, tooling, adhesion, etc. It is the responsibility of the ***Glazing Contractor*** to submit a statement from the sealant manufacturer indicating that glass and glazing materials have been tested for compatibility and adhesion with glazing sealants, and interpreting test results relative to material performance, including recommendations for primers and substrate preparation required to obtain adhesion. The chemical compatibility of all glazing materials and framing sealants with each other and with like materials used in glass fabrication must be established. This is required on every project.











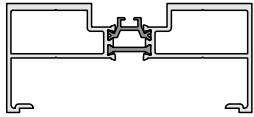
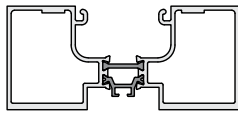
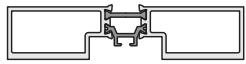
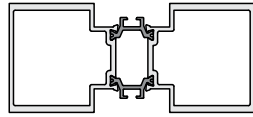
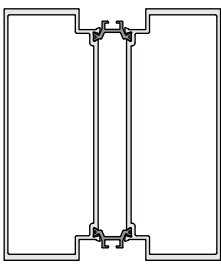

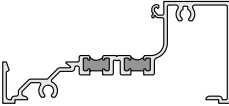

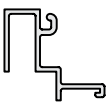
GENERAL INSTALLATION NOTES (CONTINUED)

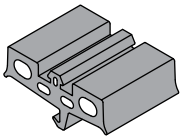
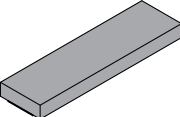
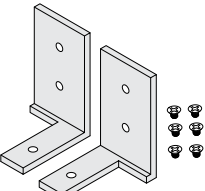
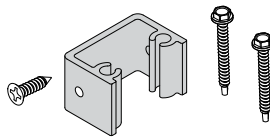
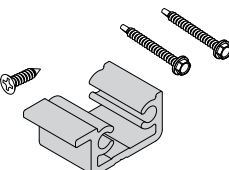
8. **FASTENING.** Within the body of these instructions "fastening" means any method of securing one part to another or to adjacent materials. Only those fasteners used within the system are specified in these instructions. Due to the varying perimeter conditions and performance requirements, perimeter and anchor fasteners are not specified in these instructions. For perimeter and anchor fasteners refer to the shop drawings or consult the fastener supplier.
9. **BUILDING CODES.** Due to the diversity in state/provincial, local, and federal laws and codes that govern the design and application of architectural products, it is the responsibility of the individual architect, owner, and installer to assure that products selected for use on projects comply with all the applicable building codes and laws. U.S. Aluminum exercises no control over the use or application of its products, glazing materials, and operating hardware, and assumes no responsibility thereof.
10. **EXPANSION JOINTS.** Expansion joints and perimeter seals shown in these instructions and in the shop drawings are shown at normal size. Actual dimensions may vary due to perimeter conditions and/or difference in metal temperature between the time of fabrication and the time of installation. Gaps between expansion members should be based on temperature at time of installation.
11. **WATER HOSE TEST.** As soon as a representative amount of the wall has been glazed (500 square feet or 46.5 m²) a water hose test should be conducted in accordance with AAMA 501.2 specifications to check the installation. On all jobs the hose test should be repeated every 500 square feet (46.5 m²) during the glazing operation.
12. **COORDINATION WITH OTHER TRADES.** Coordinate with the general contractor any sequence with other trades which offset curtain wall installation (i.e. fire proofing, back-up walls, partitions, ceilings, mechanical ducts, converters, etc.)
13. **CARE AND MAINTENANCE.** Final cleaning of exposed aluminum surfaces should be done in accordance with AAMA 609.1 for anodized aluminum and 610.1 for painted aluminum.
14. **SEALANTS.** Check shop drawings, installation instructions, architectural drawings and shipping lists to become thoroughly familiar with all sealants referenced in these instructions, which must be a one part elastomeric acetic or neutral cure silicone and must be applied according to the silicone manufacturer's recommendations.
15. **APPLICATION.** Structural silicone must be applied from the interior, and weather seal from the exterior, after the interior structural silicone has fully cured.
16. **MAXIMUM ALLOWABLE STRESS ON SILICONE.** The maximum allowable size of the glass lite is controlled by the width and depth of the silicone joint combined with the specified design windload (PSF or Pa). The stress on the structural silicone must not exceed 20 PSI (137 KPa) for a 6:1 safety factor. Check Structural Silicone Chart in the Architectural Design Manual for this product series.
17. **ARCHITECT.** It is the responsibility of the architect to secure approval of the system and request from the Glazing Contractor the compatibility and adhesion test reports described below.
18. **GLAZING CONTRACTOR.** It is the responsibility of the glazing contractor to submit a statement from the sealant manufacturer indicating that glass and glazing materials have been tested for compatibility and adhesion with glazing sealants and interpreting test results relative to material performance, including recommendations for primers and substrate preparation required to obtain adhesion. The chemical compatibility of all glazing materials and framing sealants with each other and with like materials used in glass fabrication must be established. This is required on every project.
19. **U.S. ALUMINUM.** It is the responsibility of U.S. Aluminum to supply a system to meet the architect's specifications.

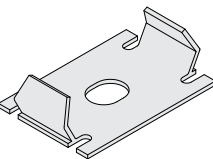
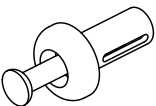
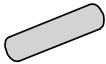
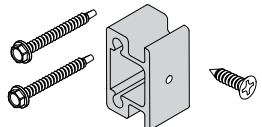
ORDER OF ASSEMBLY AND INSTALLATION

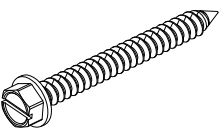
HANDLING, STORAGE, AND PROTECTION OF ALUMINUM.....	2
GENERAL INSTALLATION NOTES.....	2 - 3
PARTS IDENTIFICATION	5
DOOR GLASS FABRICATION	6
STANDARD HARDWARE LOCATIONS	7
FLOOR SLAB SLOPE GUIDELINES	7
FRAME ASSEMBLY	8 - 13
375-T Door Frame with 375T450 Jamb	8
375T451 Common Lock Jamb	9
375T452 Common Hinge Jamb	9
Series 45X Door Frame	10 - 11
Series 45X Door Frame with Transom	12 - 13
FRAME INSTALLATION	14 - 17
Series 45X Door Frame Installation	14
375-T Door Frame Installation	14
Threshold Installation	15
Mid-Seal Gasket Installation	16
Door Stop Installation	17
DOOR GLASS INSTALLATION	18
DOOR INSTALLATION	19 - 20
Offset Hung on Butt Hinges	19
Offset Hung on Gear Hinges	19
Pairs of Doors	20
FINAL ADJUSTMENTS	21

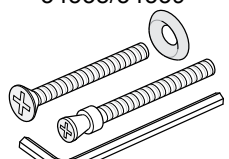
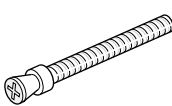
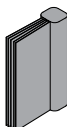
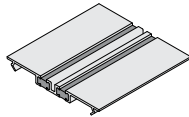
PARTS IDENTIFICATION

<p>375T454</p>  <p>2" Door Jamb</p>	<p>375T455</p>  <p>2" Door Header</p>	<p>375T450</p>  <p>1" Subframe</p>	<p>375T451</p>  <p>2" Common Lock Jamb</p>	<p>375T452</p>  <p>5-1/4" Common Hinge Jamb</p>
<p>375TTH61</p>  <p>Thermal Threshold</p>	<p>45XHB</p>  <p>Outside Glazed Sill / Inside Glazed Head</p>	<p>375T406</p>  <p>Transom Sash Kit</p>	<p>375T407</p>  <p>Transom Sash Kit</p>	<p>375T112</p>  <p>1" Door Glass Stop with 45A1133 Gasket</p>
<p>375TGP155</p>  <p>Door Frame Mid Seal Gasket</p>	<p>375TGP159</p>  <p>1" Door Setting Block</p>	<p>375TTC22</p>  <p>375T204 / 375T205 Threshold Clip Kit</p>	<p>AC13001</p>  <p>for 375T451, 375T452 Shear Block</p>	<p>AC13301</p>  <p>for 375T450 Shear Block</p>
<p>375T403</p>  <p>Door Stop with Gasket</p>	<p>375TSC1</p>  <p>for 375T403 Door Stop Spring Clip</p>	<p>45AFS15</p>  <p>for 375TSC1 3/16" x 7/16" Drive Rivet Fastener</p>	<p>45AFS24</p>  <p>use with 45AC119 7/32" x 3/4" Roll Pin</p>	<p>45AC119</p>  <p>for 45XHA, 45XHB, 45XHC Shear Block</p>
<p>375TFS55</p>  <p>for AD-114 #10 x 1/2" PHPMS</p>	<p>45AFS7</p>  <p>#10 x 3/4" FHP</p>	<p>45AFS9</p>  <p>#14 x 1-1/2" HH STS</p>	<p>375TFS22</p>  <p>#12-24 x 1/2" FHPMS</p>	<p>1032X14PFHUCZ 1032X14PFHUCZ</p>  <p>#10-32 x 1/4" FHPUC</p>
<p>34538/34539</p>  <p>Push / Pull Hardware Kit</p>	<p>375TFS67</p>  <p>Bolt for Back-to-Back Pull Handles</p>	<p>375TWP086</p>  <p>Wool Pile for Meeting Stiles</p>	<p>45AFP59</p>  <p>for 45XHB and 375T455 Head Anchor</p>	<p>45XFA</p>  <p>Vinyl Filler Caulk Stop</p>

DOOR GLASS FABRICATION

Thermal doors are available as a single, a pair, or sets of single doors that are separated by a 2" common lock or 5-1/2" hinge jamb. 6" or 10" Bottom Rails are available. Muntins are not available. Size glass as listed below for standard doors.

GLASS SIZE FOR STANDARD SINGLE DOOR

	DOOR OPENING SIZE		NET DOOR SIZE		GLASS SIZE		
	Width	Height	Width	Height	Width	Height	
						6" (152 mm) Bottom Rail	10" (254 mm) Bottom Rail
BUTT HINGE	36" (914 mm)	84" (2134 mm)	35-3/4" (908 mm)	83-1/2" (2121 mm)	27-7/8" (708 mm)	73-15/16" (1878 mm)	69-15/16" (1776 mm)
	36" (914 mm)	96" (2438 mm)	35-3/4" (908 mm)	95-1/2" (2426 mm)	27-7/8" (708 mm)	85-15/16" (2183 mm)	81-15/16" (2081 mm)
	42" (1067 mm)	84" (2134 mm)	41-3/4" (1061 mm)	83-1/2" (2121 mm)	33-7/8" (860 mm)	73-15/16" (1878 mm)	69-15/16" (1776 mm)
	42" (1067 mm)	96" (2438 mm)	41-3/4" (1061 mm)	95-1/2" (2426 mm)	33-7/8" (860 mm)	85-15/16" (2183 mm)	81-15/16" (2081 mm)
GEAR HINGE	36" (914 mm)	84" (2134 mm)	35-9/16" (914 mm)	83-1/2" (2121 mm)	27-7/8" (708 mm)	73-15/16" (1878 mm)	69-15/16" (1776 mm)
	36" (914 mm)	96" (2438 mm)	35-9/16" (914 mm)	95-1/2" (2426 mm)	27-7/8" (708 mm)	85-15/16" (2183 mm)	81-15/16" (2081 mm)
	42" (1067 mm)	84" (2134 mm)	41-9/16" (1056 mm)	83-1/2" (2121 mm)	33-7/8" (860 mm)	73-15/16" (1878 mm)	69-15/16" (1776 mm)
	42" (1067 mm)	96" (2438 mm)	41-9/16" (1056 mm)	95-1/2" (2426 mm)	33-7/8" (860 mm)	85-15/16" (2183 mm)	81-15/16" (2081 mm)

GLASS SIZE FOR STANDRAD DOUBLE DOOR

	DOOR OPENING SIZE		NET DOOR SIZE		GLASS SIZE		
	Width	Height	Width	Height	Width	Height	
						6" (152 mm) Bottom Rail	10" (254 mm) Bottom Rail
BUTT HINGE	72" (1829 mm)	84" (2134 mm)	35-3/4" (908 mm)	83-1/2" (2121 mm)	27-7/8" (708 mm)	73-15/16" (1878 mm)	69-15/16" (1776 mm)
	84" (2134 mm)	96" (2438 mm)	35-3/4" (908 mm)	95-1/2" (2426 mm)	27-7/8" (708 mm)	85-15/16" (2183 mm)	81-15/16" (2081 mm)
	72" (1829 mm)	84" (2134 mm)	41-3/4" (1061 mm)	83-1/2" (2121 mm)	33-7/8" (860 mm)	73-15/16" (1878 mm)	69-15/16" (1776 mm)
	84" (2134 mm)	96" (2438 mm)	41-3/4" (1061 mm)	95-1/2" (2426 mm)	33-7/8" (860 mm)	85-15/16" (2183 mm)	81-15/16" (2081 mm)
GEAR HINGE	72" (1829 mm)	84" (2134 mm)	35-9/16" (914 mm)	83-1/2" (2121 mm)	27-7/8" (708 mm)	73-15/16" (1878 mm)	69-15/16" (1776 mm)
	84" (2134 mm)	96" (2438 mm)	35-9/16" (914 mm)	95-1/2" (2426 mm)	27-7/8" (708 mm)	85-15/16" (2183 mm)	81-15/16" (2081 mm)
	72" (1829 mm)	84" (2134 mm)	41-9/16" (1056 mm)	83-1/2" (2121 mm)	33-7/8" (860 mm)	73-15/16" (1878 mm)	69-15/16" (1776 mm)
	84" (2134 mm)	96" (2438 mm)	41-9/16" (1056 mm)	95-1/2" (2426 mm)	33-7/8" (860 mm)	85-15/16" (2183 mm)	81-15/16" (2081 mm)

GLASS SIZE FOR CUSTOM SINGLE DOOR

Width	Height with 6" (152 mm) Bottom Rail	Height with 10" (254 mm) Bottom Rail
Door Opening Width minus 8-1/8" (206 mm)	Opening Height minus 10-1/16" (256 mm)	Opening Height minus 14-1/16" (357 mm)

GLASS SIZE FOR CUSTOM DOUBLE DOOR

Width	Height with 6" (152 mm) Bottom Rail	Height with 10" (254 mm) Bottom Rail
Door Opening Width minus 8-1/8" (206 mm) divided by 2	Opening Height minus 10-1/16" (256 mm)	Opening Height minus 14-1/16" (357 mm)

375T450 Subframe is 1" wide x 4-1/2" deep. 375T454 Subframe is 2" x 4-1/2". Center Hung Doors are not available. All doors shall use a minimum of 1-1/2" pair of Butt Hinges or FM-SLI Continuous Gear Hinge. Offset Pivots are not available.

ROUGH OPENING WITH 375T450 1" SUBFRAME:

Width: Door Opening plus 2-1/2" (64 mm)

Height: Door Opening plus 1-1/4" (32 mm) Minimum

ROUGH OPENING WITH 375T454 2" SUBFRAME FOR 45X STOREFRONT:

Width: Door Opening plus 4-1/2" (114 mm)

Height: Door Opening plus 2-1/4" (57 mm) Minimum

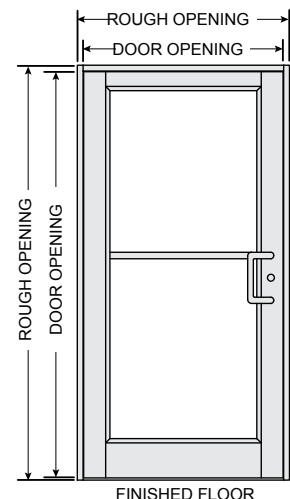

STANDARD HARDWARE LOCATIONS

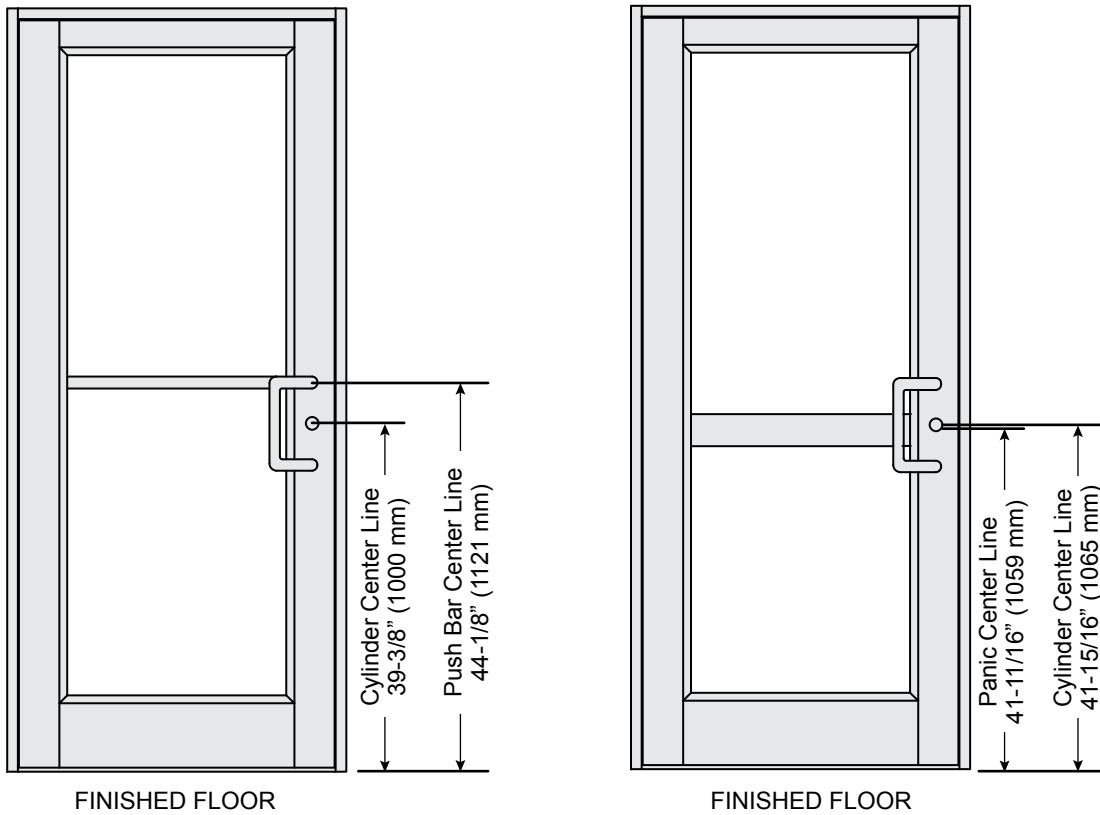

FLOOR SLAB SLOPE GUIDELINES

Substrate at exterior of door must slope a minimum of 1 degree to maintain water flow to the exterior.

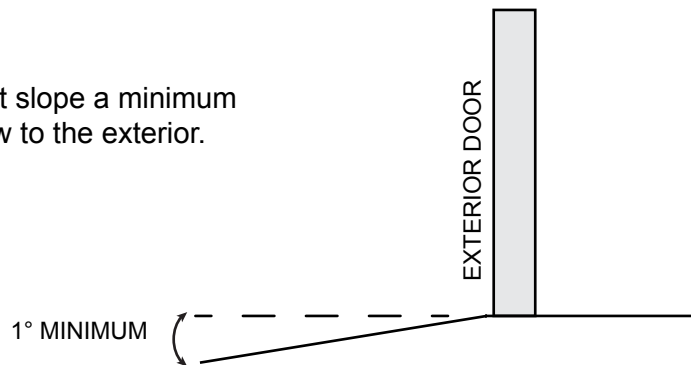

FRAME ASSEMBLY

375-T Door Frame with 375T450 Jamb

- ① Install Shear Blocks on Jambs.
- ② Install Left and Right Threshold Clips.
- ③ Apply Sealant to Shear Blocks.

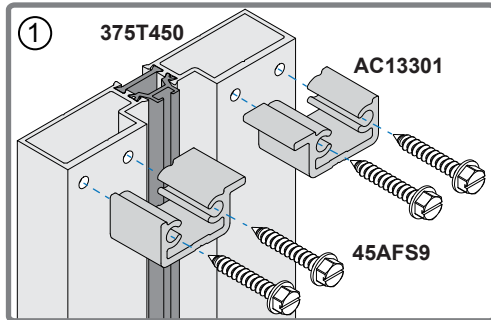

- ④ Slide Header over Shear Blocks.
- ⑤ Attach Header to Shear Blocks.
- ⑥ Clean excess sealant.

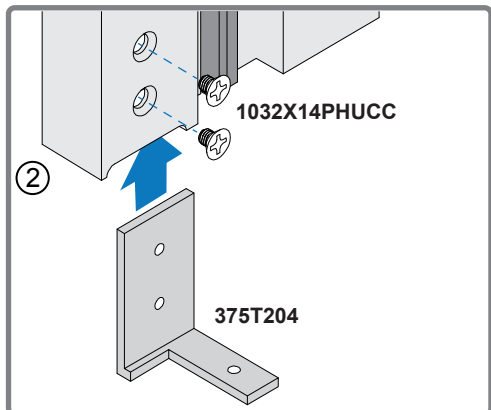

- ⑦ Temporarily attach Threshold to Left and Right Threshold Clips.

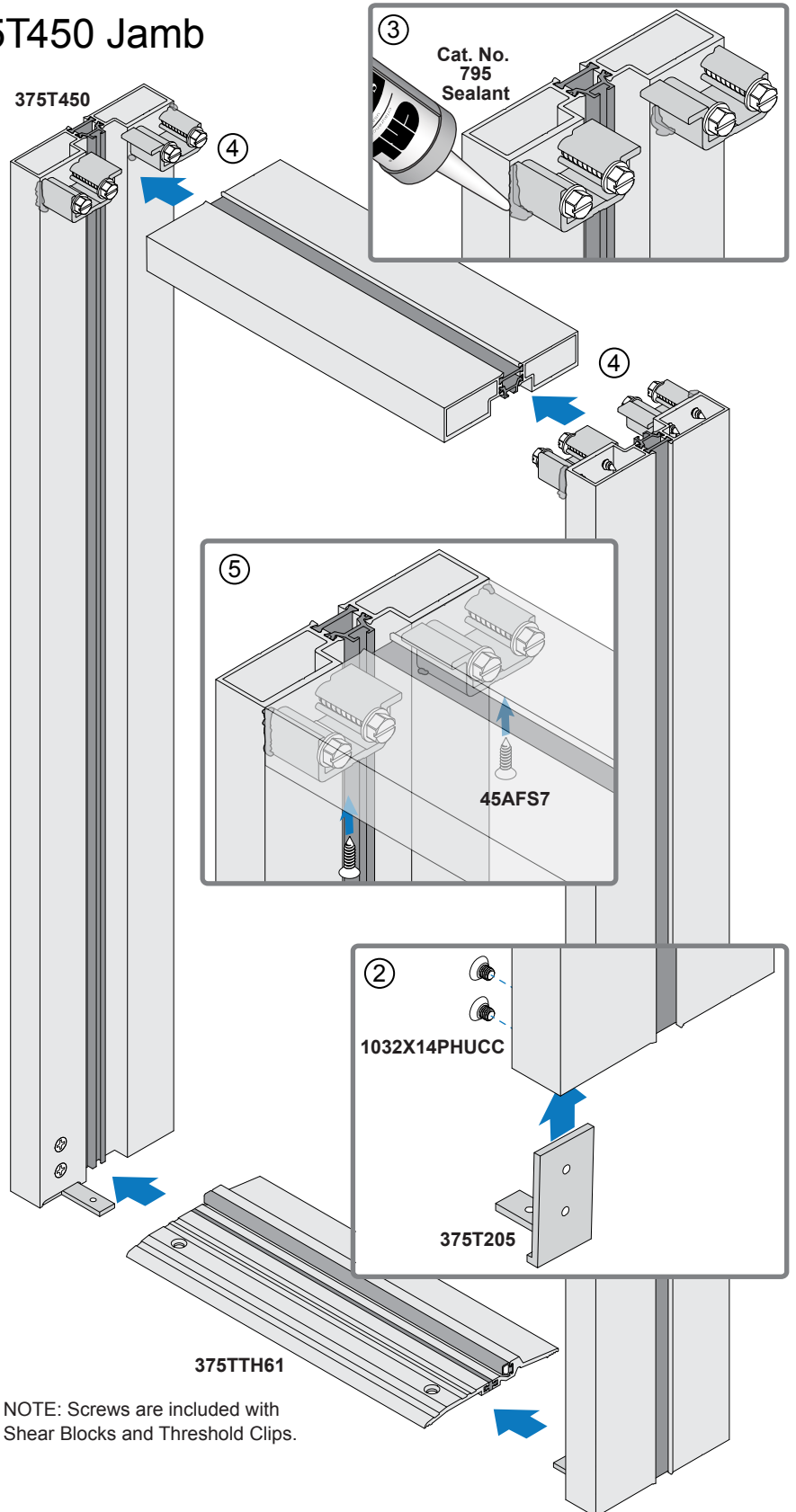
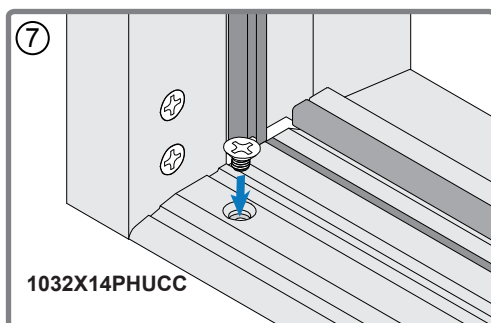

NOTE: Screws are included with Shear Blocks and Threshold Clips.

NOTE: After the frame is installed into opening, the Threshold will be removed to seal and drill for anchors.

FRAME ASSEMBLY (CONTINUED)

375T451 Common Lock Jamb

- ① Install Shear Blocks on Header.
- ② Apply Sealant to Shear Blocks.
- ③ Slide Lock Jamb over Shear Blocks.
- ④ Attach Lock Jamb to Shear Blocks.
- ⑤ Clean excess sealant.

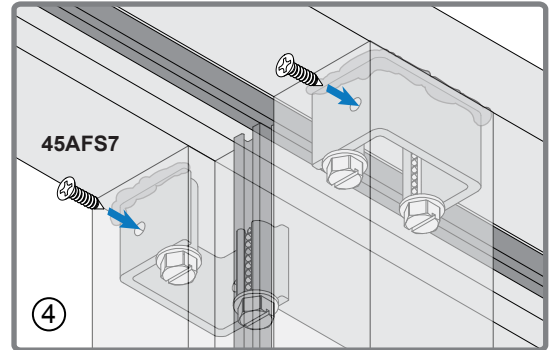
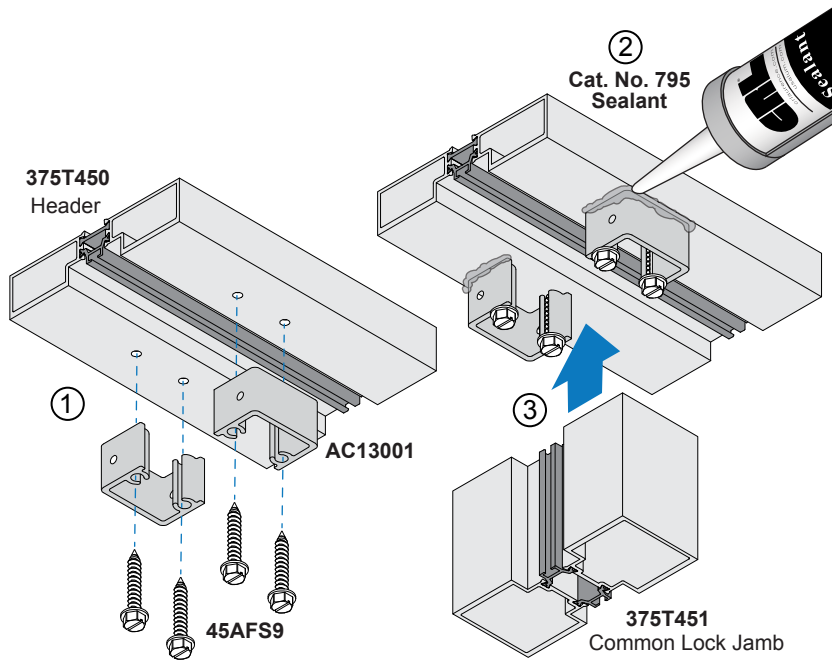

NOTE: Screws are included with Shear Blocks

375T452 Common Hinge Jamb

- ① Install Shear Blocks on Header.
- ② Apply Sealant to Shear Blocks.
- ③ Slide Hinge Jamb over Shear Blocks.
- ④ Attach Hinge Jamb to Shear Blocks.
- ⑤ Clean excess sealant.

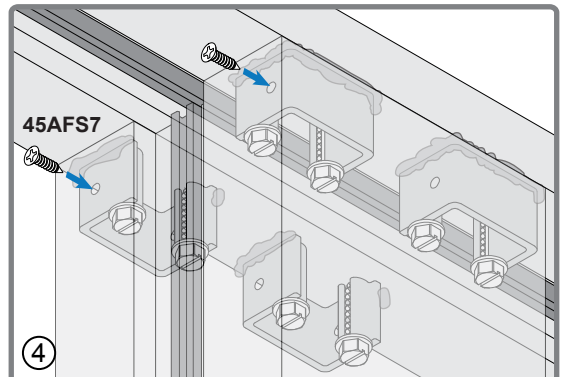
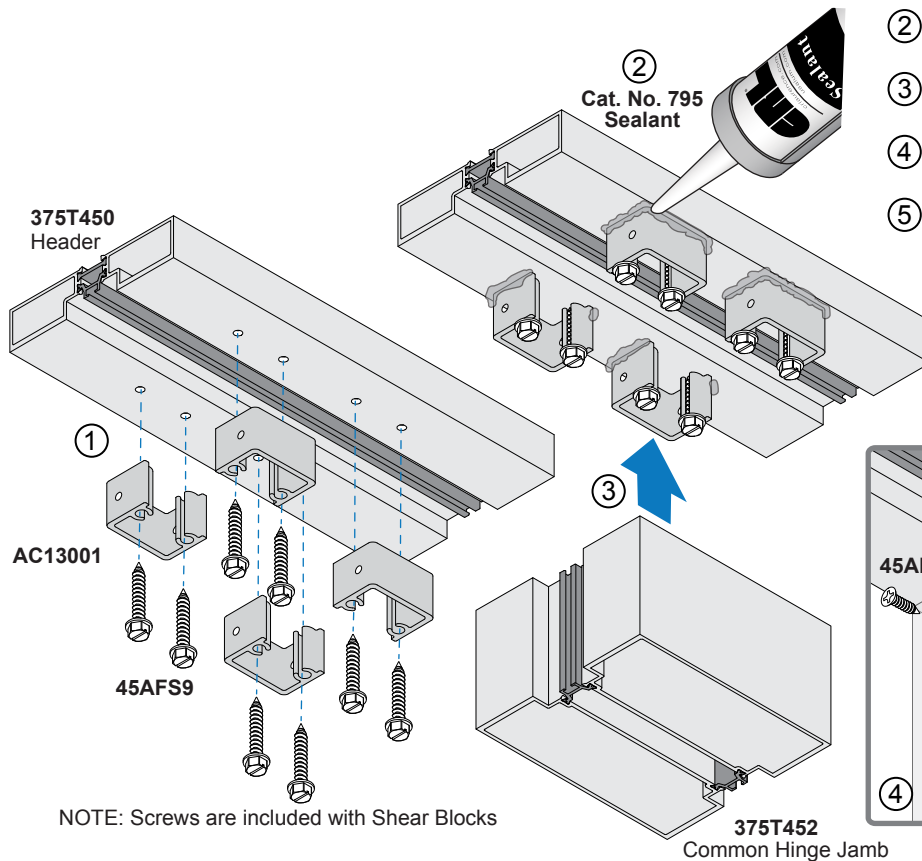

NOTE: Screws are included with Shear Blocks

FRAME ASSEMBLY (CONTINUED)

Series 45X Door Frame

- ① Install Shear Blocks on Jamb.
- ② Install Left and Right Threshold Clips.
- ③ Apply Sealant to Shear Blocks.

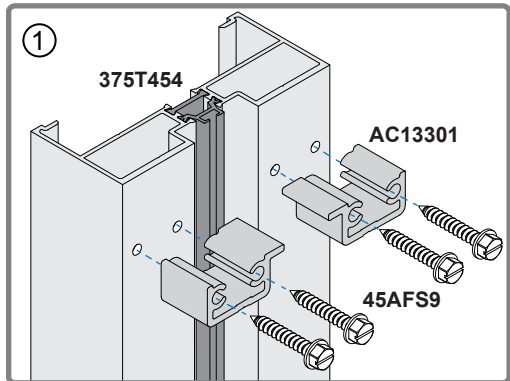

- ④ Slide Header over Shear Blocks.
- ⑤ Attach Header to Shear Blocks.
- ⑥ Clean excess sealant.

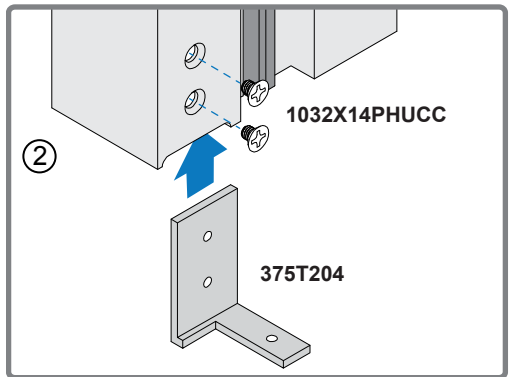

- ⑦ Temporarily attach Threshold to Left and Right Threshold Clips.

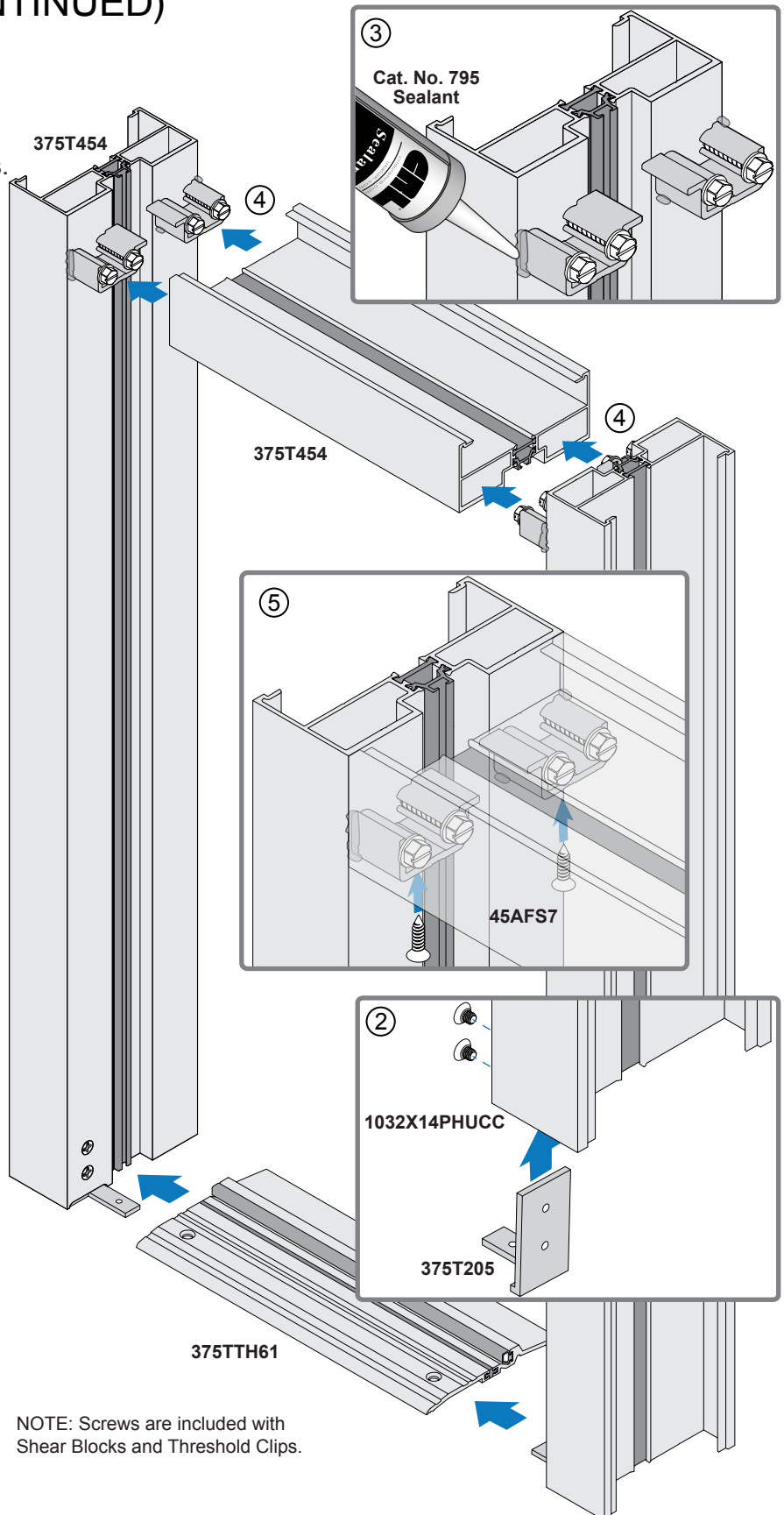
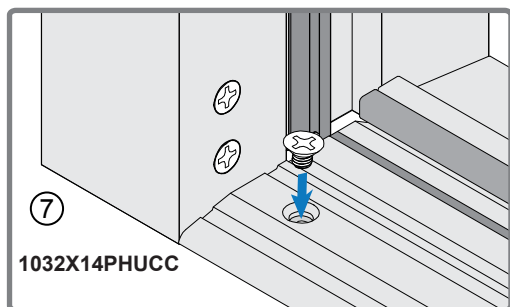

NOTE: After the frame is installed into opening, the Threshold will be removed to seal and drill for anchors.

FRAME ASSEMBLY (CONTINUED)

Series 45X Door Frame (Continued)

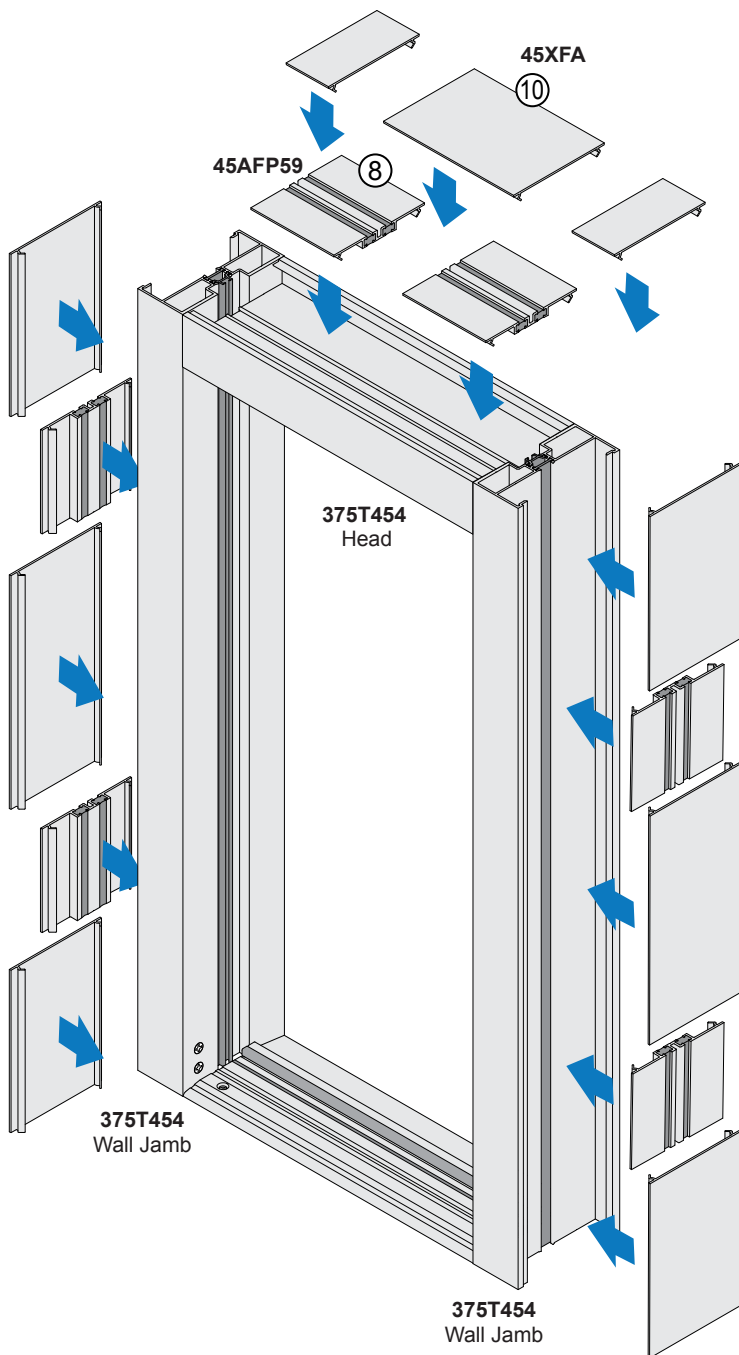

- ⑧ Install 45AFP59 Head Anchors on each end of Head, 4" away from each Jamb and at all Anchor Points on Jambs.

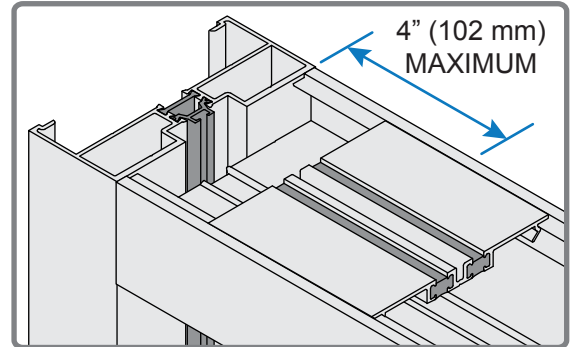

- ⑨ Drill through Anchors, Head and Jambs at all Anchor Points. Refer to Shop Drawings for Anchor size and frequency.

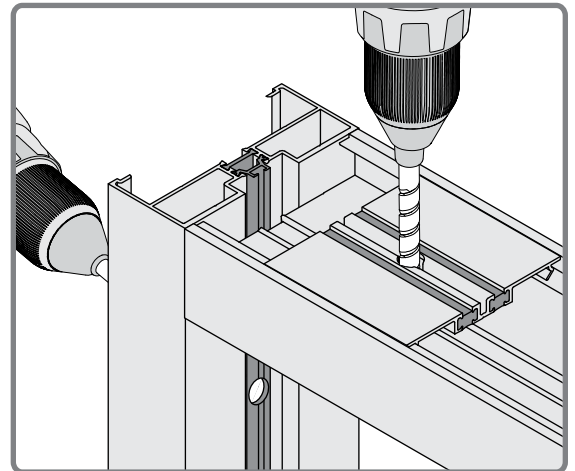

- ⑩ Install 45XFA PVC Filler between Anchors at Head (required) and at Jambs (optional) to improve perimeter seals.

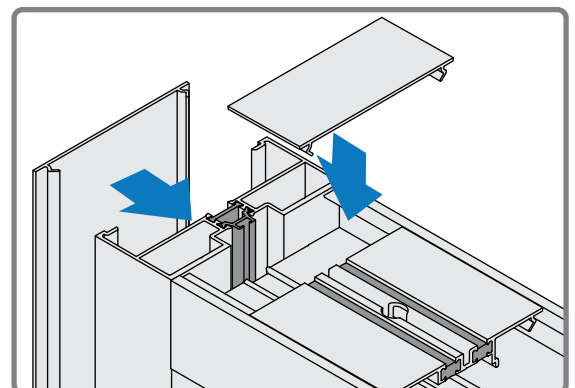

FRAME ASSEMBLY (CONTINUED)

Series 45X Door Frame with Transom

- ① Install Shear Blocks on Jambs.
- ② Install Left and Right Threshold Clips.
- ③ Apply Sealant to Shear Blocks.

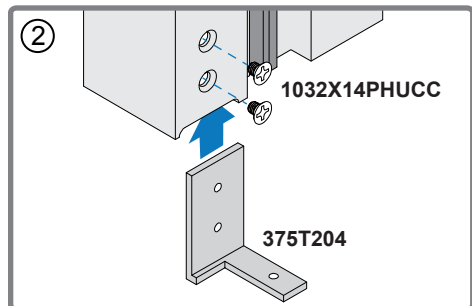
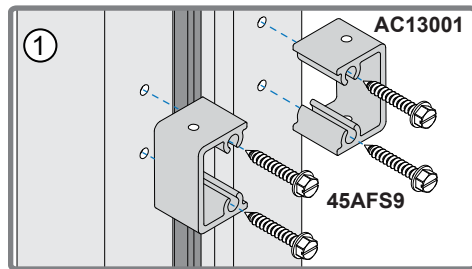
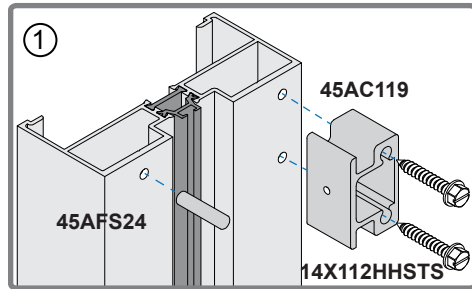
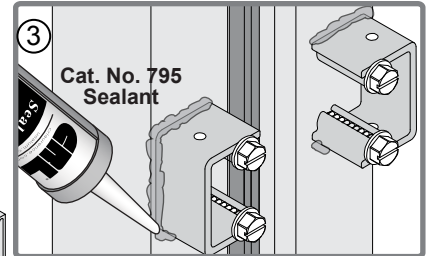
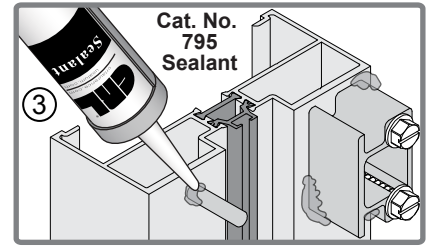

- ④ Slide Header over Shear Blocks.
- ⑤ Attach Header to Shear Blocks.
- ⑥ Clean excess sealant.
- ⑦ Temporarily attach Threshold to Left and Right Threshold Clips.

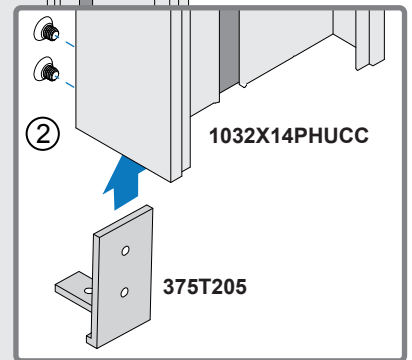
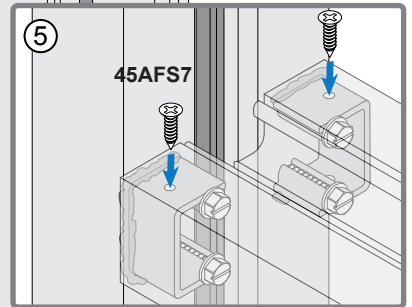
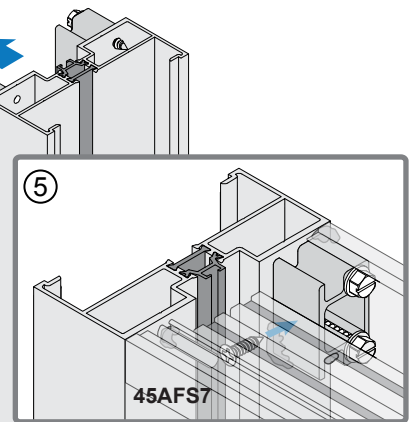
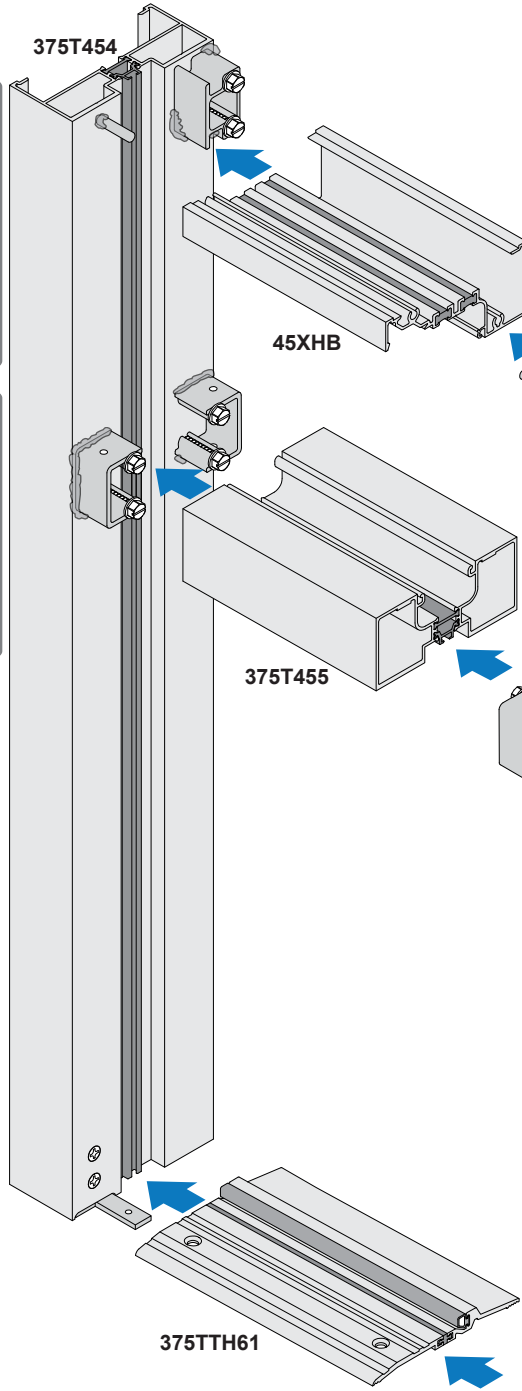
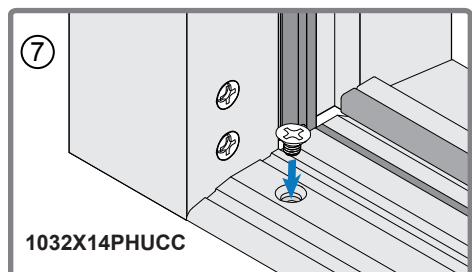

NOTE: Screws are included with Shear Blocks and Clips. 45AFS24 Roll Pin is packaged separately.

NOTE: After the frame is installed into opening, the threshold will be removed to seal and drill for anchors.

FRAME ASSEMBLY (CONTINUED)

Series 45X Door Frame with Transom (Continued)

⑧ Follow Steps 8 through 10 on Page 11 to install Anchors and Filler and then follow instructions on Pages 14 - 21 to install and adjust frame and door.

⑨ Install Interior Transom Sash Kit.

⑩ Install Interior Gaskets.

⑪ Install Setting Block.

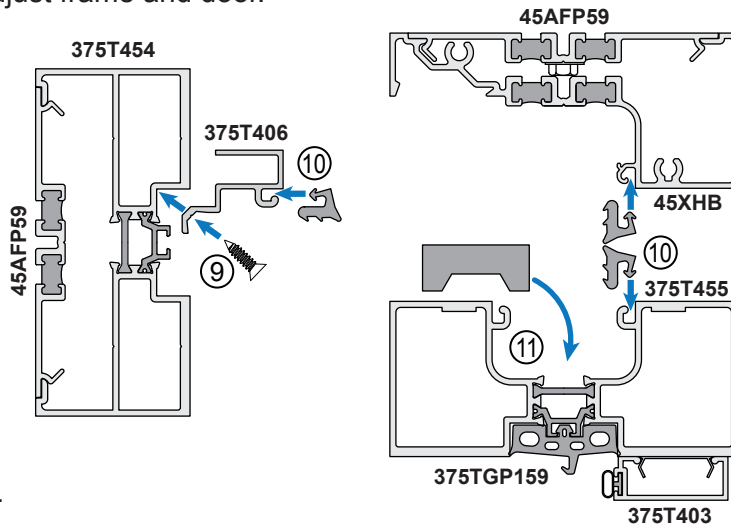

⑫ Install Transom Glass and center.

⑬ Snap Exterior Transom Sash Kit and Glass Stop into place.

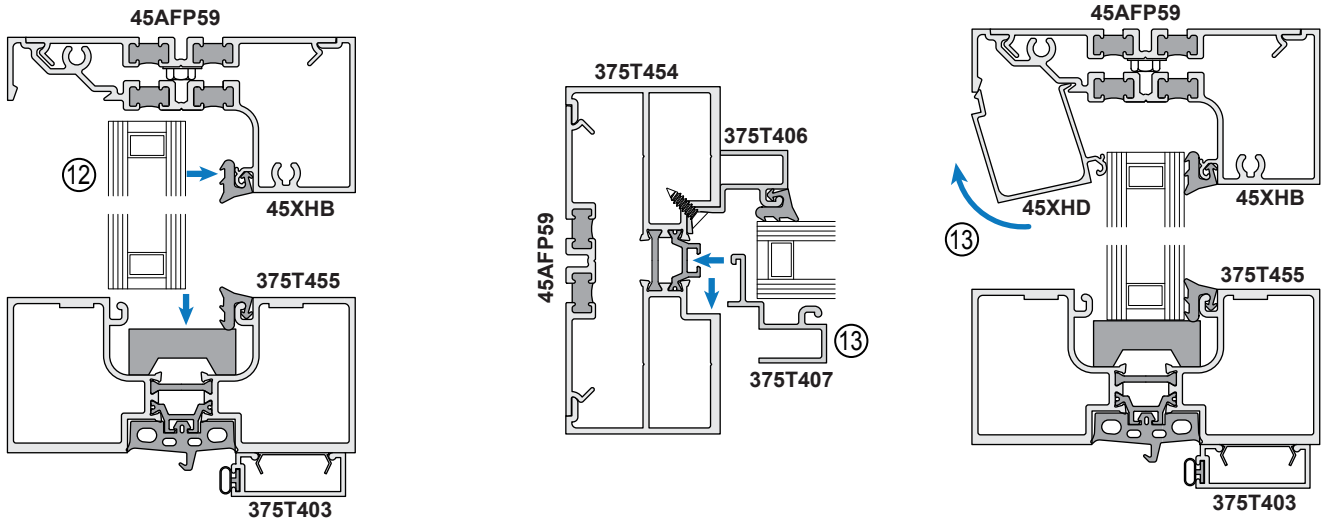

⑭ Install Exterior Gaskets.

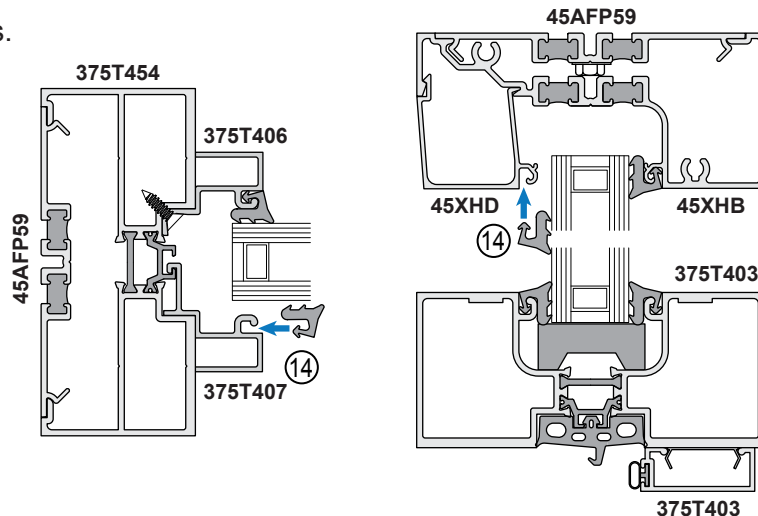

FRAME INSTALLATION

Install Door Frame completely assembled with all joints neatly aligned and tight.
Ensure frame is plumb and square

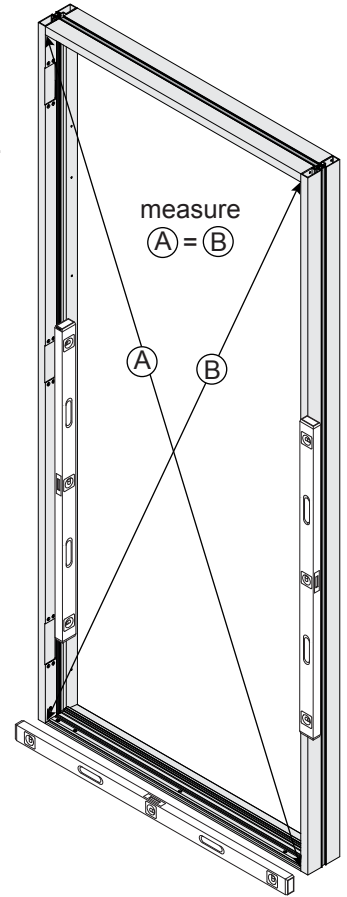

Series 45X Door Frame Installation

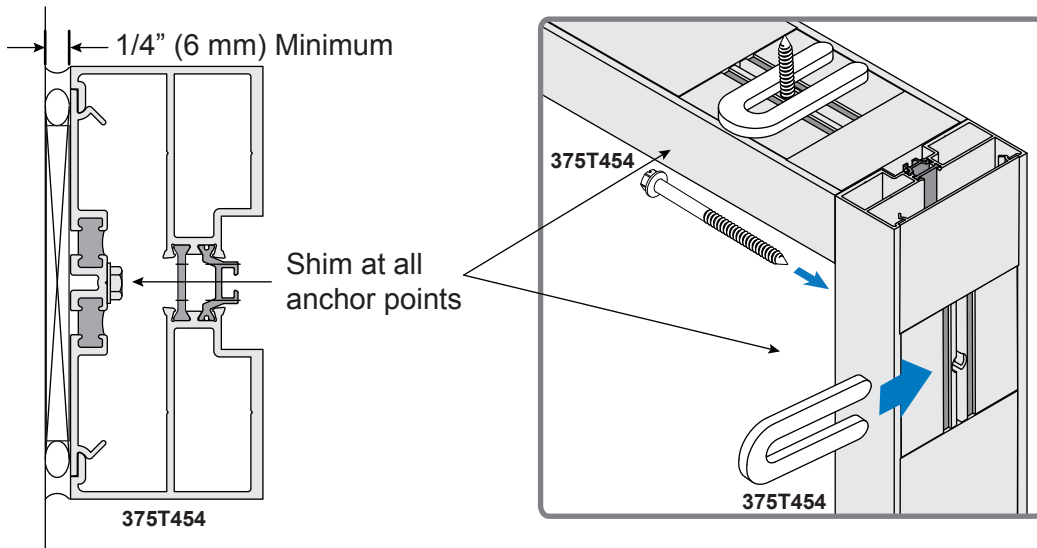

375-T Door Frame Installation

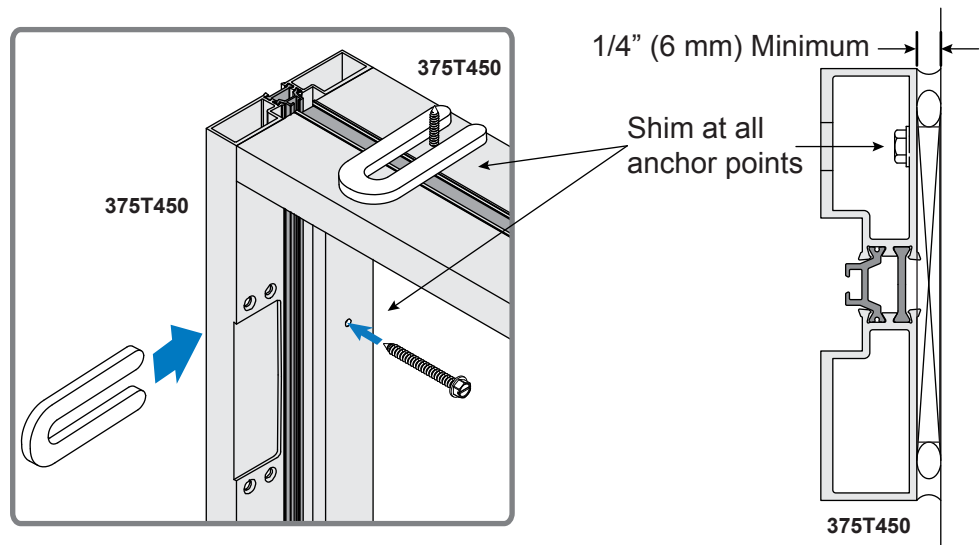

FRAME INSTALLATION (CONTINUED)

Threshold Installation

- ① Mark front and back of Threshold.
- ② Mark Anchor Holes.
- ③ Detach Threshold and remove.

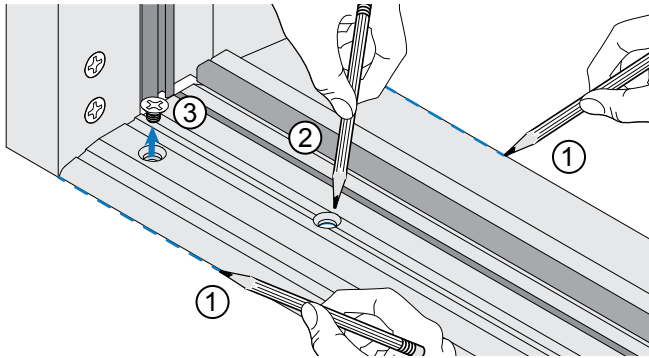

- ④ Apply continuous bead of sealant inside lines marked.
- ⑤ Drill for Anchor Bolts.

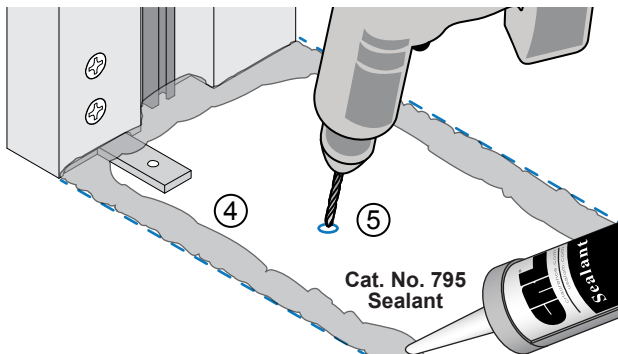

- ⑥ Install Threshold and attach to Threshold Clips.
- ⑦ Fill cavity with silicone.
- ⑧ Fill Anchor Holes with silicone and then install Anchor Bolts.

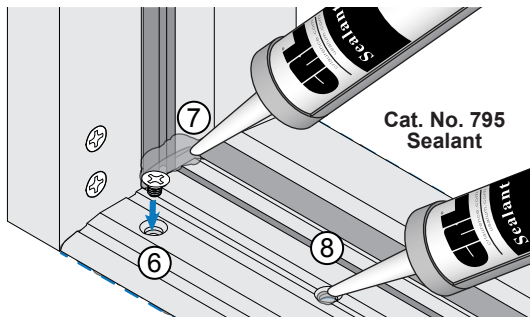

NOTE: Flat Head Anchor Bolts to be specified by a qualified engineer.

FRAME INSTALLATION (CONTINUED)

Mid-Seal Gasket Installation

- ① Cut Mid-Seal Gasket for Jambs and Header.
Notch both ends of length to be installed in Header.

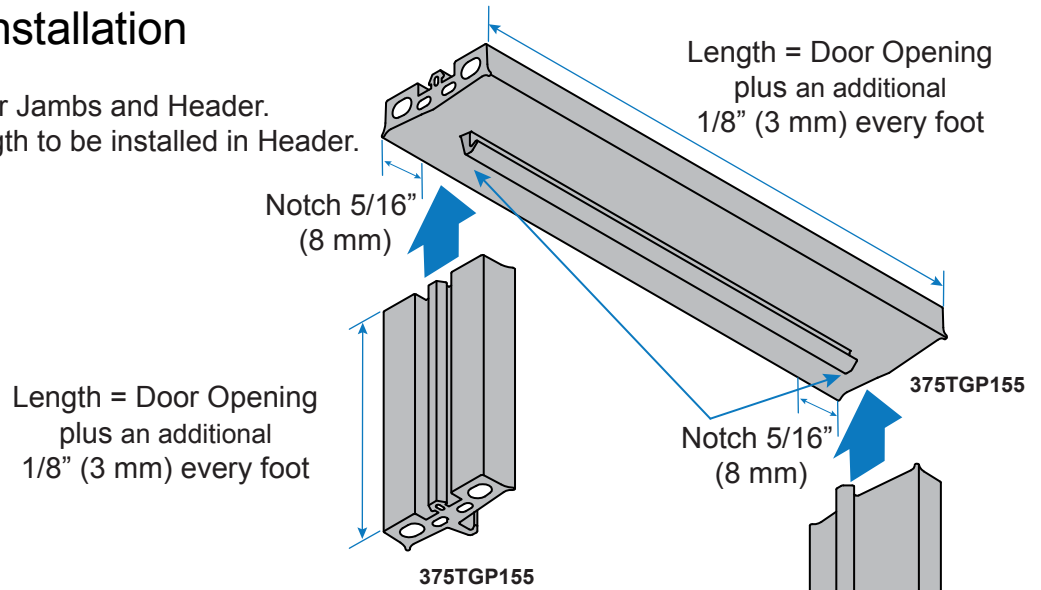

- ② Install Gasket in Header. Jamb Gaskets will butt against notched ends.
NOTE: Spray gaskets with Glass Cleaner to prevent binding during installation.

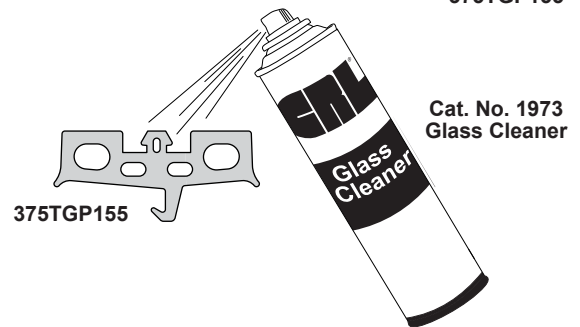
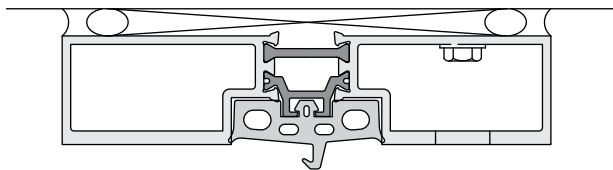

- ③ Seal ends of gaskets together at top corners.

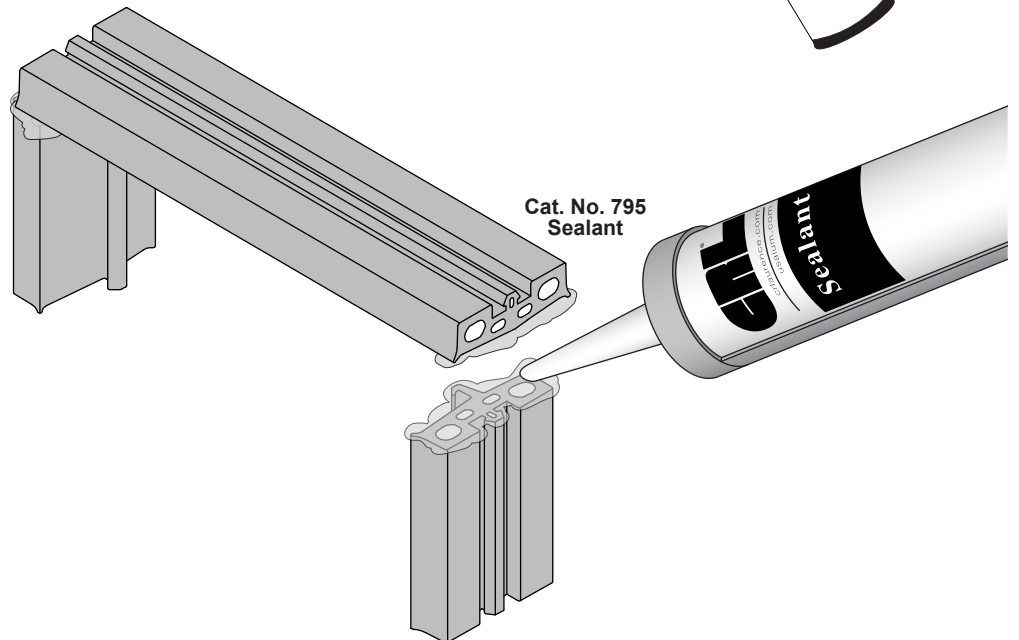
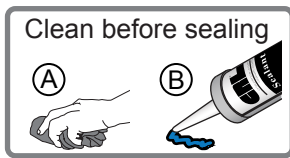

FRAME INSTALLATION (CONTINUED)

Door Stop Installation

- ① Install 375TSC1 Spring Clips with 45AFS15 Drive Rivets in Door Jamb at factory drilled holes.
- ② Apply bead of sealant on vertical Door Jamb as shown.
- ③ Snap Door Stop in place and tool excess sealant.

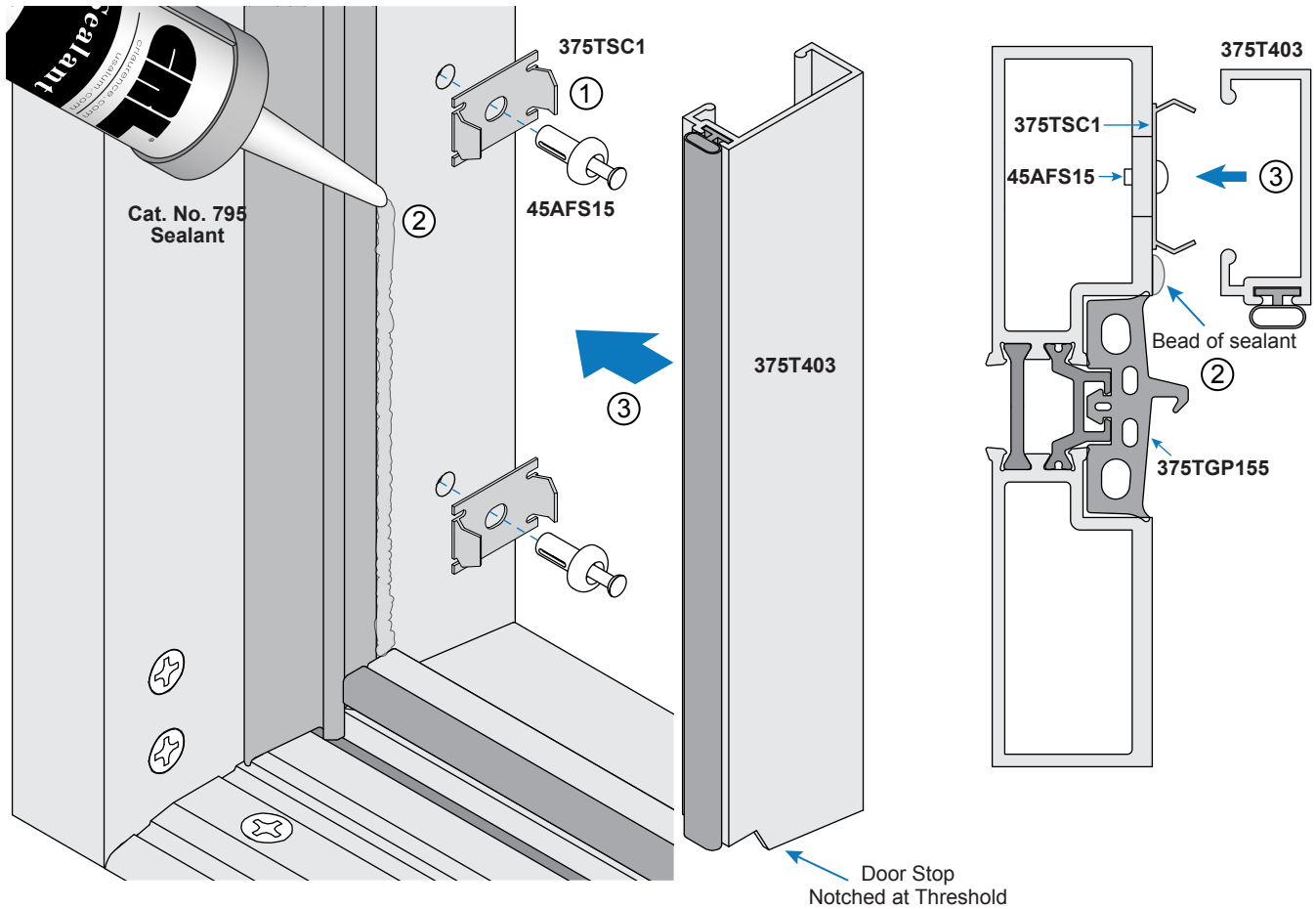

- ④ Seal Door Stop at Threshold and over Threshold Bulb Gasket. Continue to seal Threshold to Door Jamb.

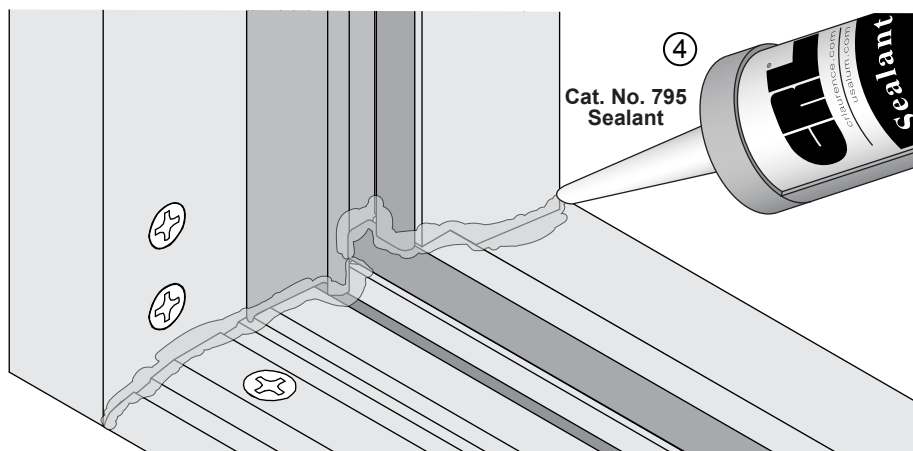

DOOR GLASS INSTALLATION

Glass setting blocks are installed in their proper positions at the factory.

NOTE: If glazing after installation, lock the door to prevent swinging and ensure glass is firmly against interior stops before installing exterior stops.

- ① Lay door on saw horses and remove Exterior Glass Stops.
- ② Cut and install Interior Gaskets.

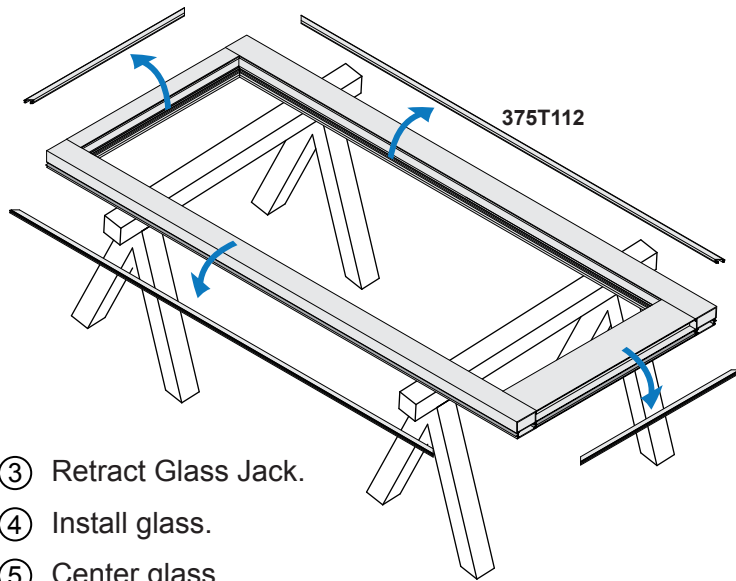
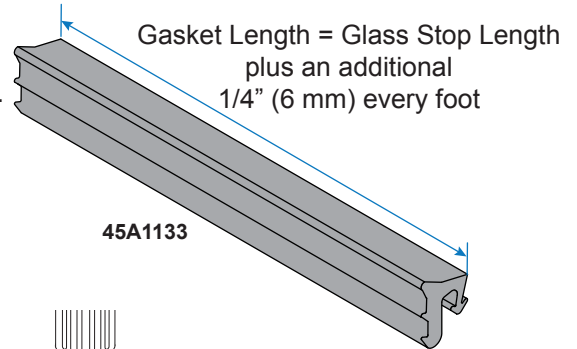

- ③ Retract Glass Jack.
- ④ Install glass.
- ⑤ Center glass.
- ⑥ Tighten Glass Jack so it rests lightly on glass.
- ⑦ Install Vertical Exterior Glass Stops.
- ⑧ Install Horizontal Exterior Glass Stops.
- ⑨ Install Exterior Gaskets.

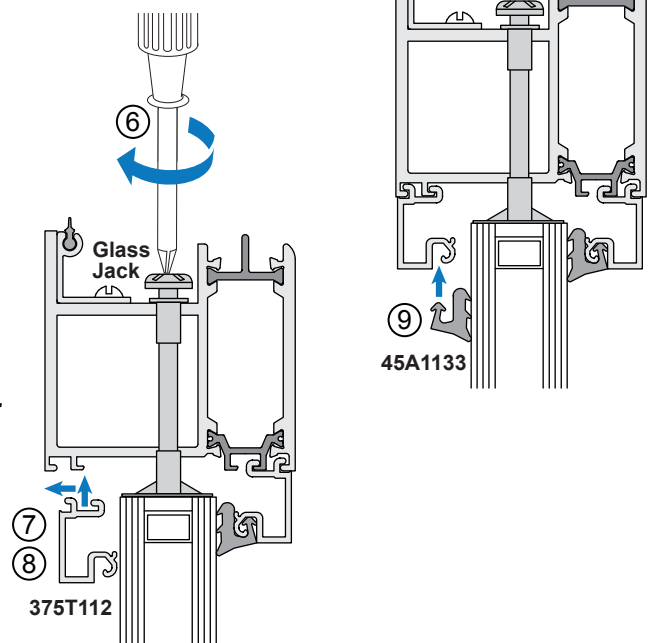
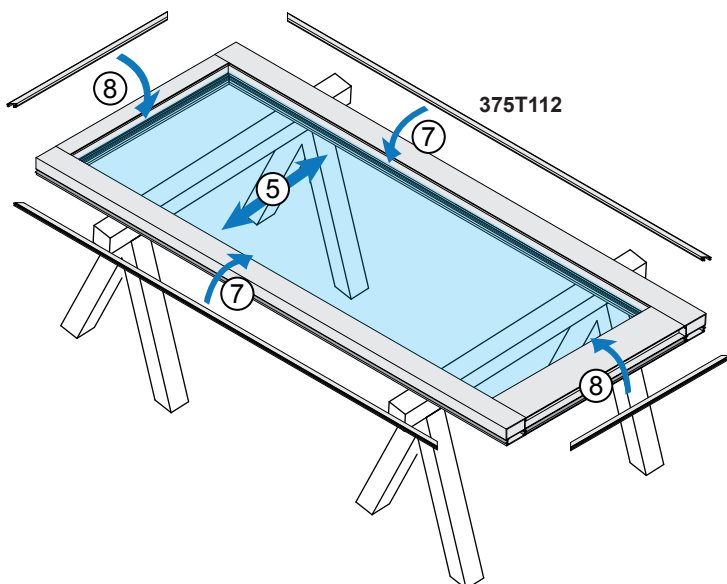
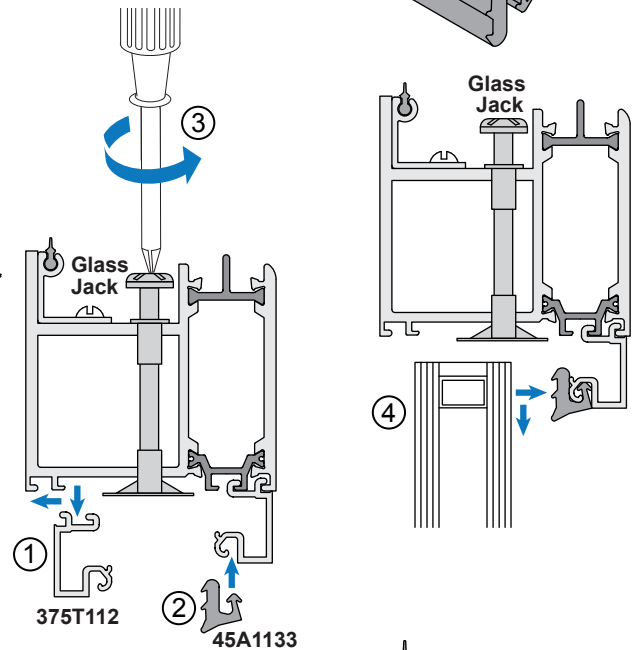

DOOR INSTALLATION

Offset Hung on Butt Hinges

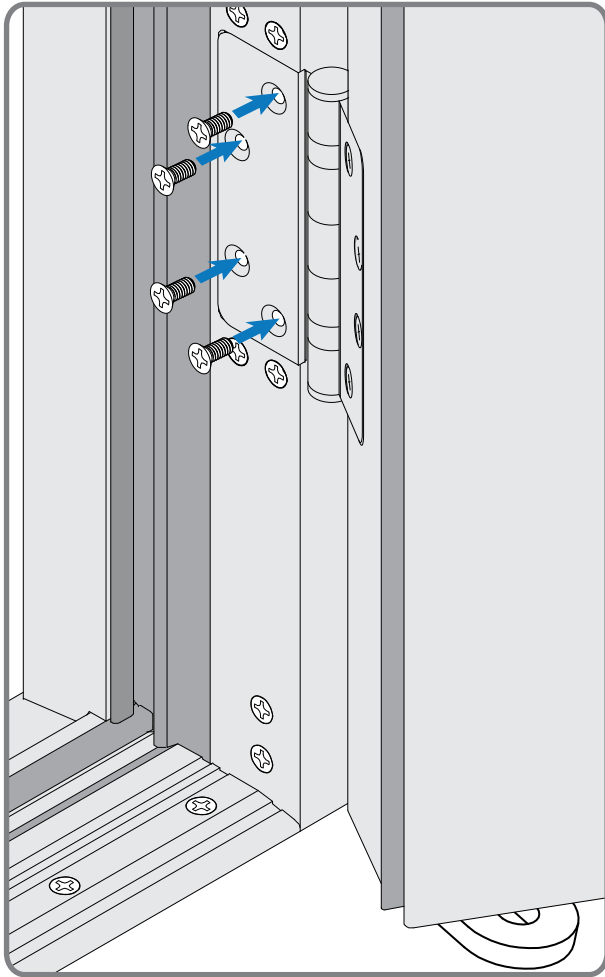

Block door while securing with included fasteners.

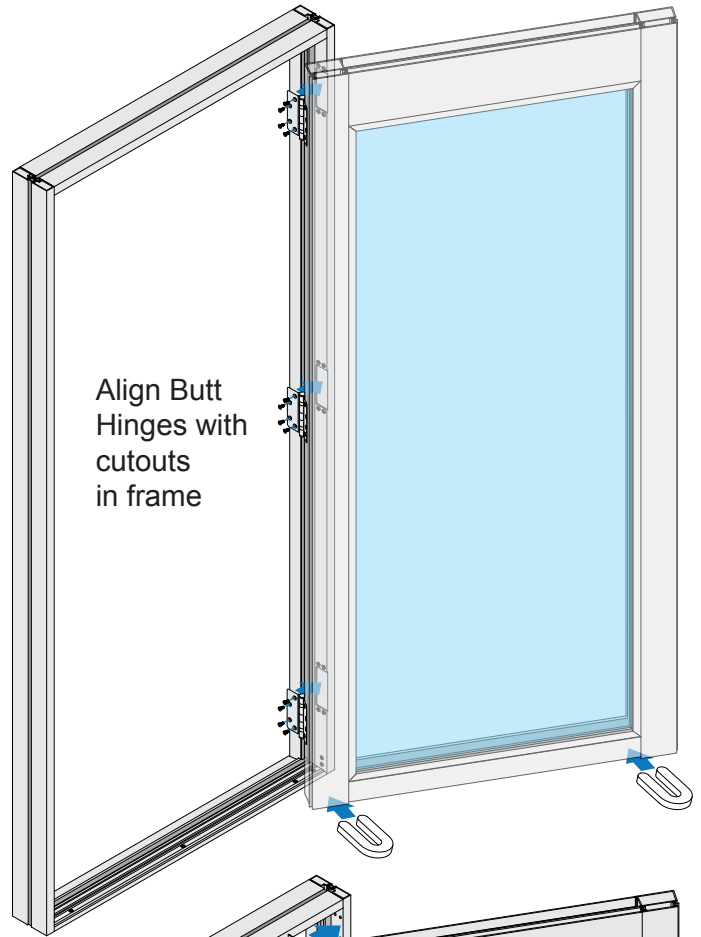

Align Butt Hinges with cutouts in frame

Offset Hung on Gear Hinges

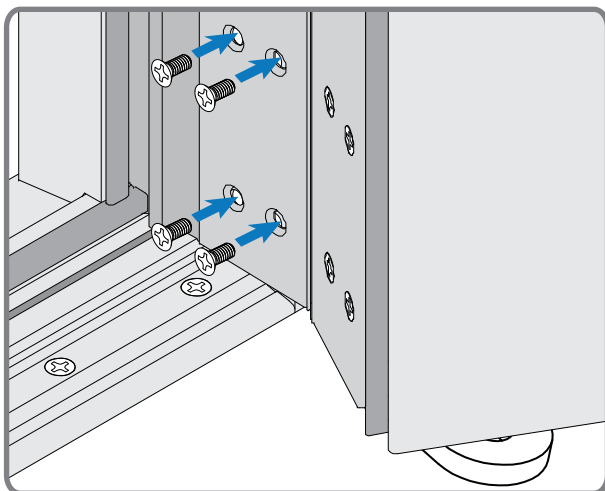

Block door while securing with included fasteners.

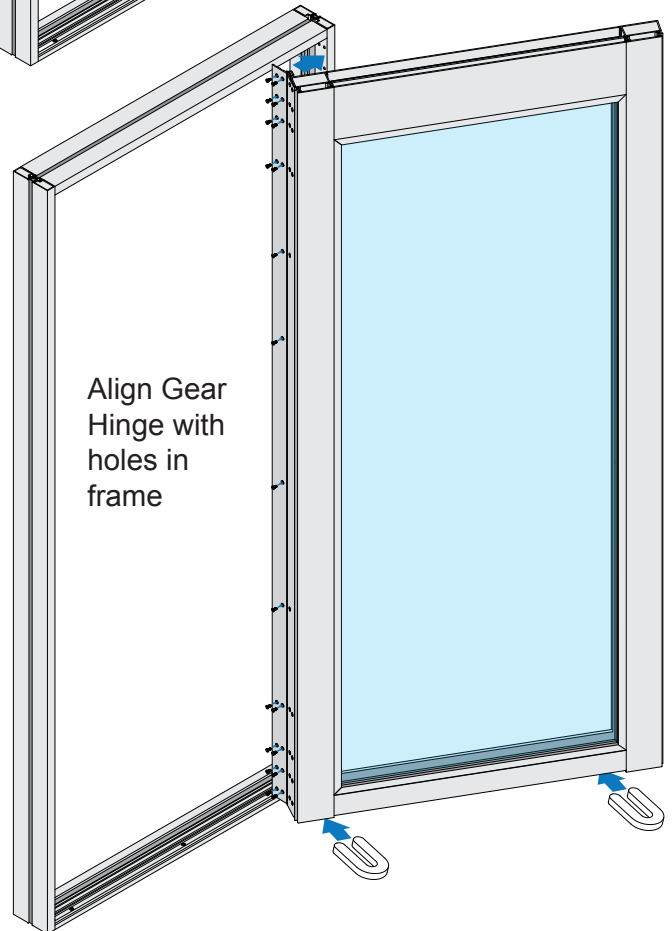

Align Gear Hinge with holes in frame

DOOR INSTALLATION (CONTINUED)

Pairs of Doors

② Adjust Astragal so Wool Pile seals lightly, touching at center.

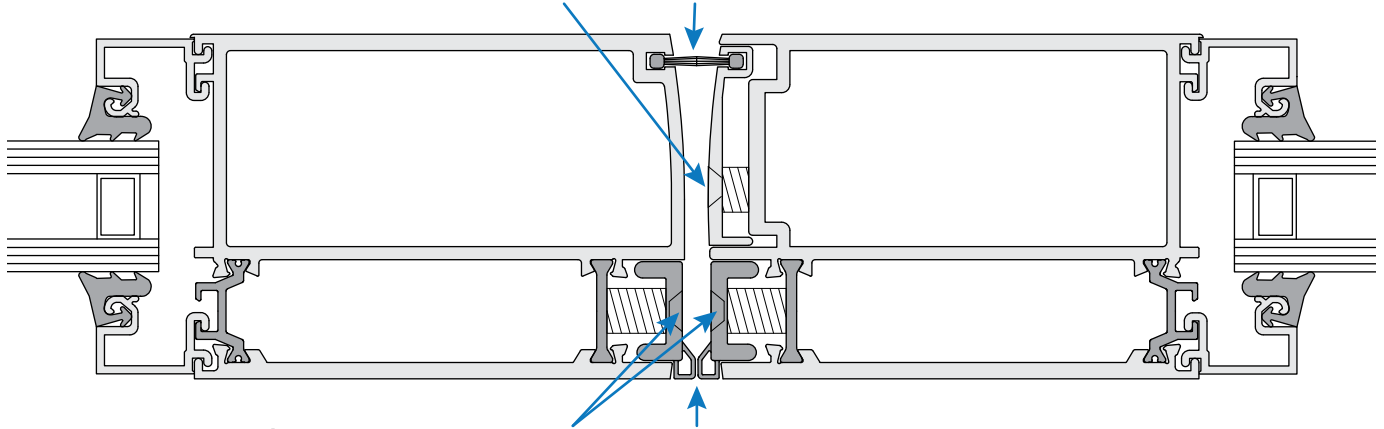

① Adjust each Astragal so Bulb Gaskets lightly touch at center.

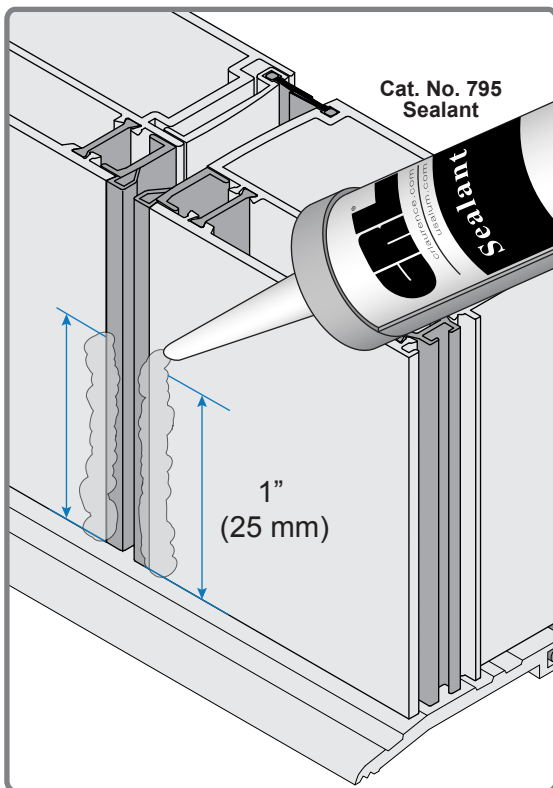

③ Seal and tool flat 1" (25 mm)

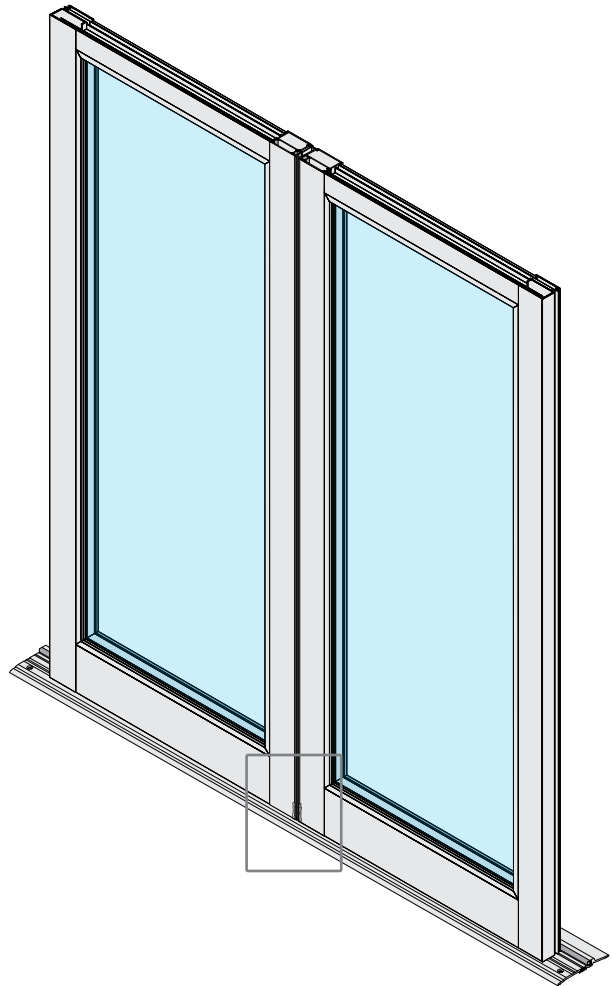

FINAL ADJUSTMENTS

After door is installed, check to assure clearances are consistent. Use Glass Jack to adjust up to 1/8" (3 mm) up or down.

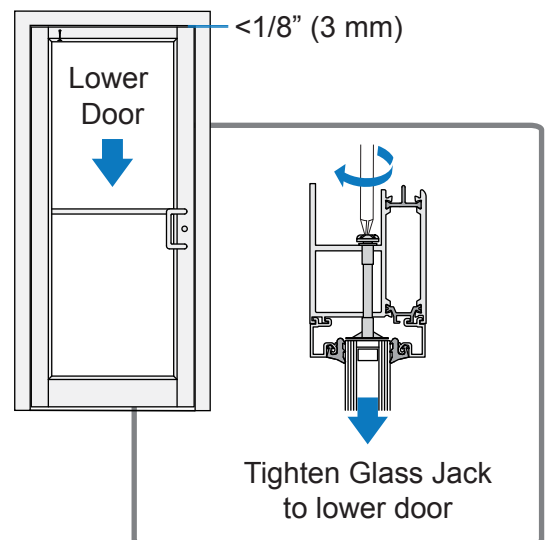
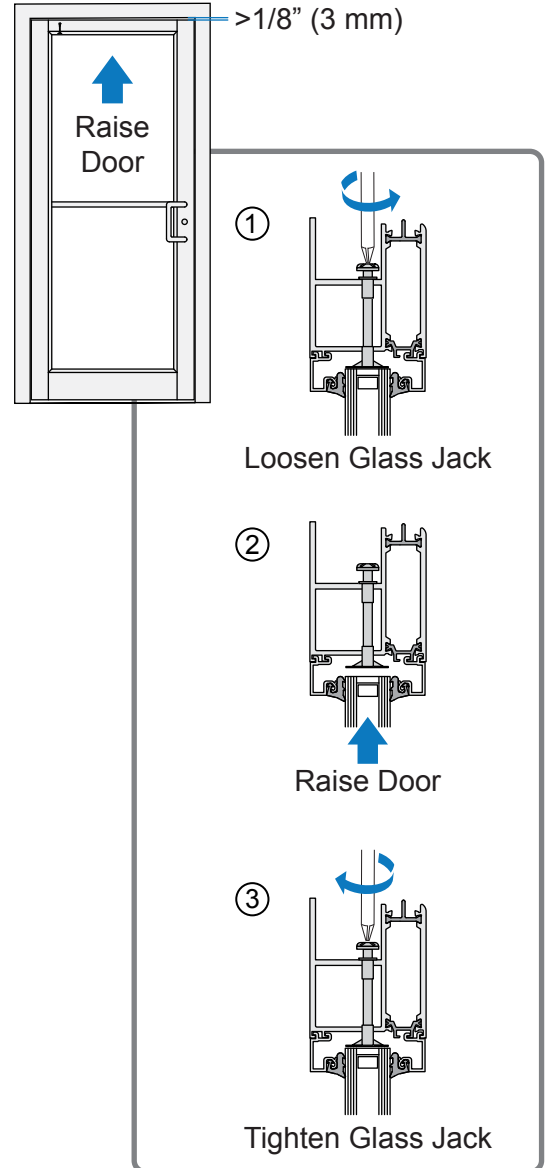
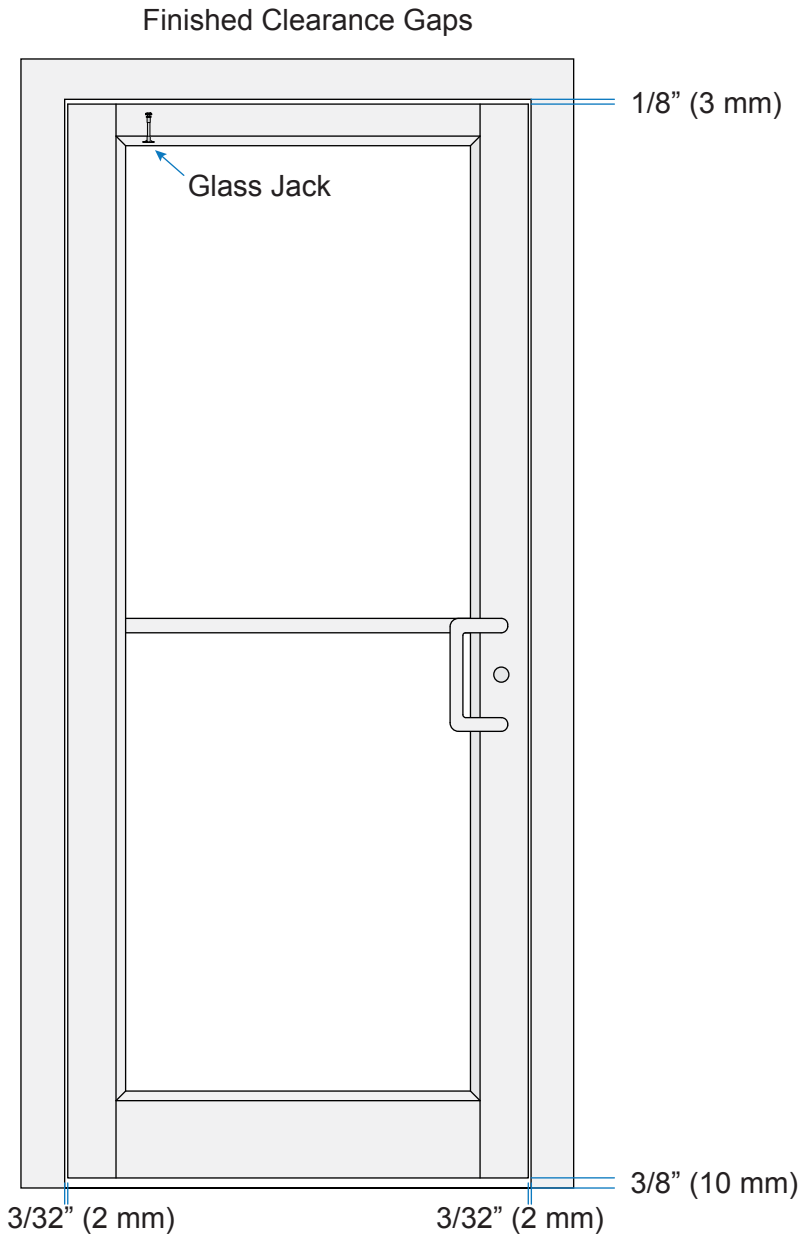

NOTE: Butt Hinge Doors may be shimmed out at Butt Hinges to reduce gap at Lock Stile.