



Assembly Manual and User Guide

Ecomposter Sphere and Optional Base



BEFORE YOU BEGIN, MAKE SURE YOU CAREFULLY READ AND UNDERSTAND THE INSTRUCTIONS IN THIS MANUAL. Please follow the instructions in the order presented in this manual and be sure to observe all warnings and cautions. Allow two hours to assemble the Ecomposter. If you have any questions or problems, please contact Customer Service.



Systems Trading Corporation
450 7th Avenue, Suite 2809, New York NY 10123
Phone: (800) 293-2923 Email: customerservice@ecomposter.net

TABLE OF CONTENTS

Step 1: Unpack Ecomposter Sphere	1
Step 2: Prepare One Sphere Panel	2
Step 3: Prepare One Half Sphere	3
Step 4: Assemble One Half Sphere	4-5
Step 5: Install Air Tubes	6
Step 6: Assemble Other Half Sphere	6
Step 7: Assemble Center Ring	7
Step 8: Install Center Ring	8
Step 9: Attach Top Sphere	9
Step 10: Install Lids	10
Standard Base Assembly	
Step 1: Unpack Standard Base	11
Step 2: Assemble Standard Base	11-12
Using Your Ecomposter	13-14
Warranty	15

Step 1: Unpack Ecomposter Sphere

Unpack your Ecomposter and make sure you have the following components to assemble the sphere. If you are missing any components, please contact Customer Service at (800) 293-2923.

NOTE: We have included extra pieces for some of the smaller parts.

COMPONENTS:

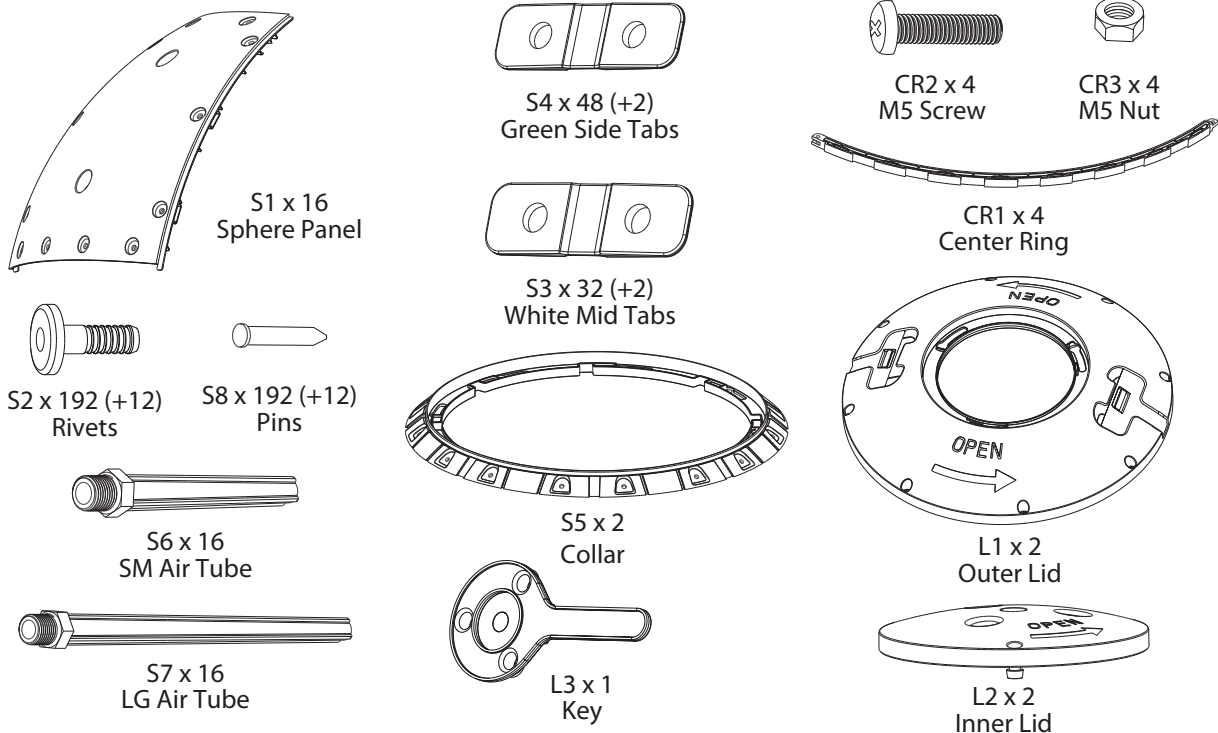

TOOLS NEEDED:

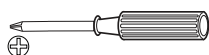

Phillips Screwdriver

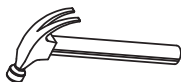

Hammer



Gloves

RECOMMENDED TOOLS:



Rubber Mallet

Step 2: Prepare One Sphere Panel

Components:

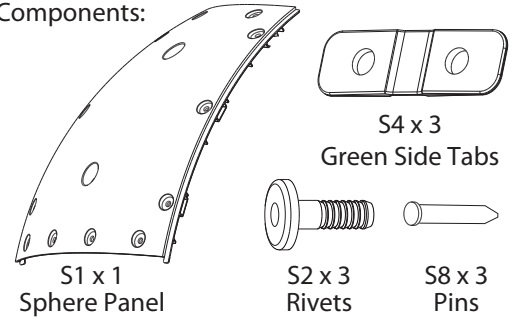

A

view from outside

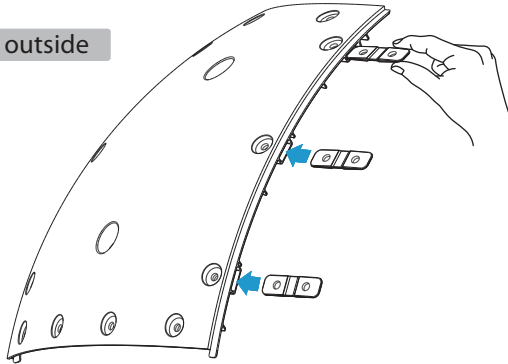

With inside panel facing down, insert three green S4 side tabs into slots on the right side.

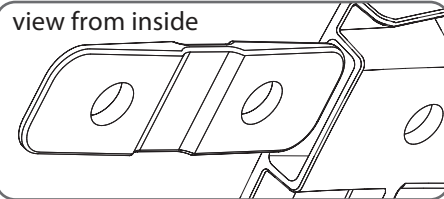

NOTE: Green S4 side tabs are the same on both sides.

B

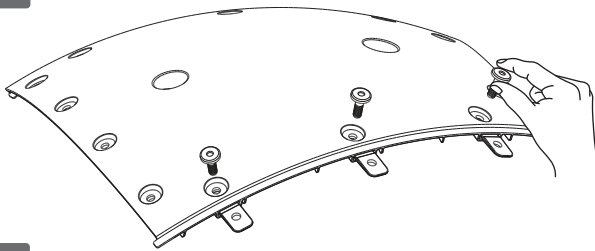

Place three S2 rivets into the holes in the panel and the side tabs to hold in place.

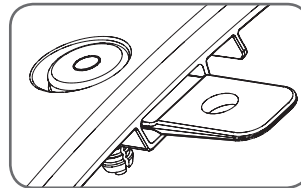

C

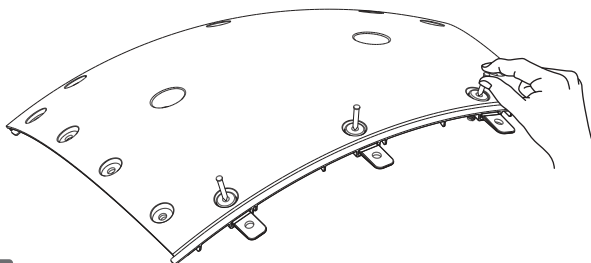

Place an S8 pin into the hole in the center of each rivet. The pin will slide half way into the rivet. Insert the other two S8 pins.

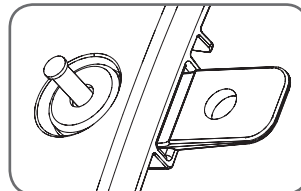

D

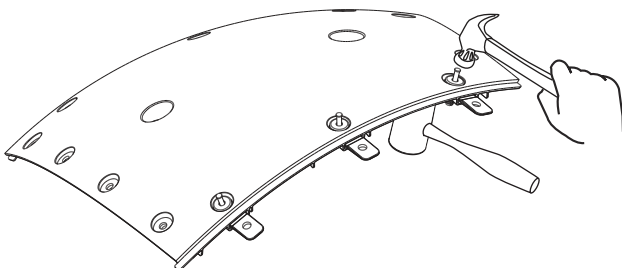

Use a rubber mallet (or block of wood) to create a brace. Hammer pin into each rivet until flush.

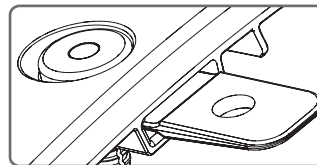

NOTE: Hammer pin until it is flush with the top of the rivet and the rivet is flush with the hole in the panel.

E

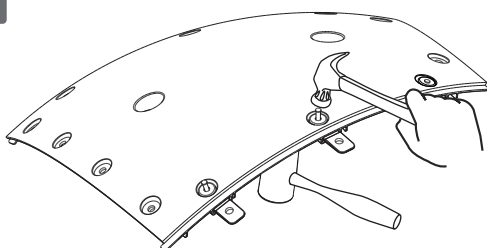

Adjust mallet and hammer the other pins into rivets until flush.

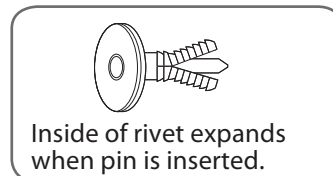

Step 3: Prepare One Half Sphere

Components:

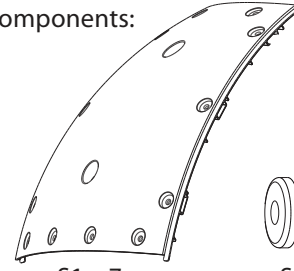

S1 x 7
Sphere Panel

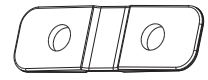

S4 x 21
Green Side Tabs

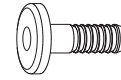

S2 x 21
Rivets



S8 x 21
Pins

A

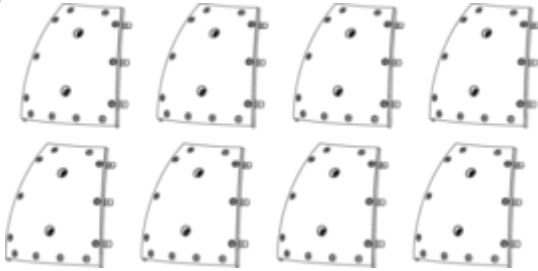

Repeat Step 2 to prepare seven more sphere panels. You now have eight sphere panels with three side tabs attached to the right side.

B

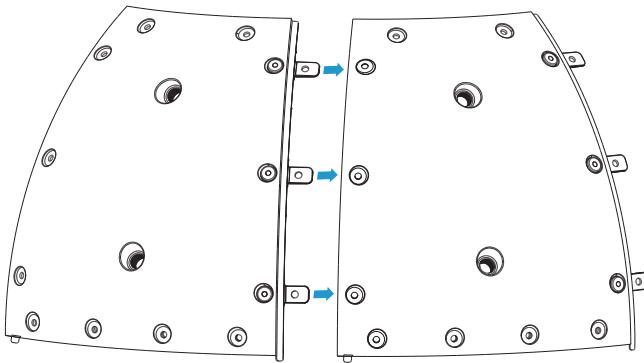

Fit the side tabs of the first panel into the slots on the left hand side of a second panel.

C

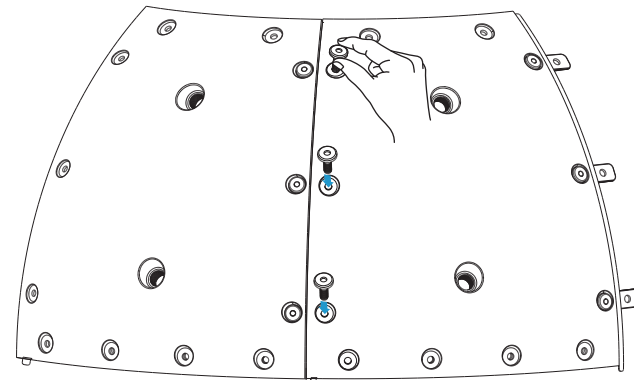

Place three S2 rivets into the holes in the panel and the side tabs to hold in place.

NOTE: You will hammer pins into all the rivets in Step 4E.

D

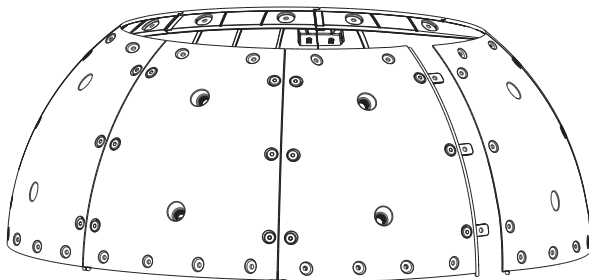

Repeat steps B and C to connect the next six panels.

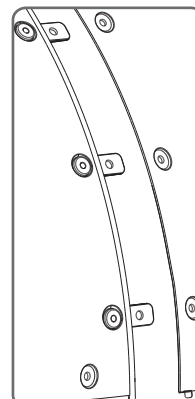

Do NOT connect the first panel to the last panel. Leave one side open. You will connect it in Step 4C.



IMPORTANT: DO NOT connect the first panel to the last panel. LEAVE ONE SIDE OPEN.

Step 4: Assemble One Half Sphere

! Wear gloves. The edges of the collar are sharp.



Components:

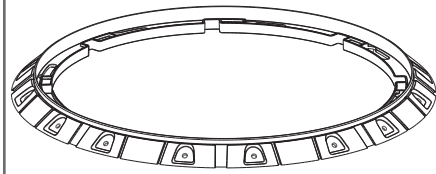

S5 x 1
Collar

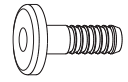

S2 x 19
Rivets

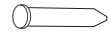

S8 x 40
Pins

A

The collar fits on the inside of the top of the sphere. Gently pull the sphere apart to fit the collar UNDER the top of the panel.

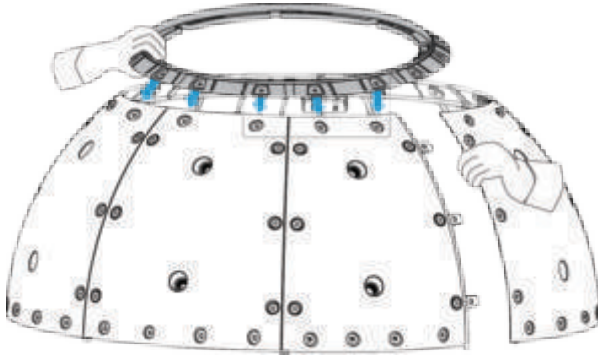

Line up the holes in the collar with the holes in the top of the panels.

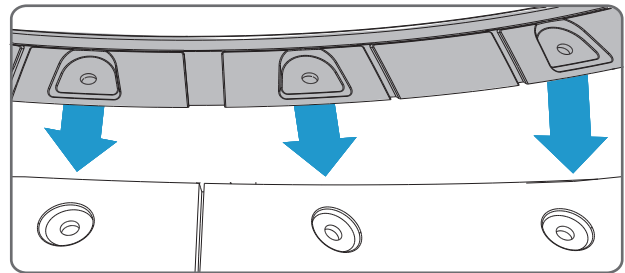

B

Starting with an open panel, place S2 rivets into holes in the top panel and collar to hold in place.

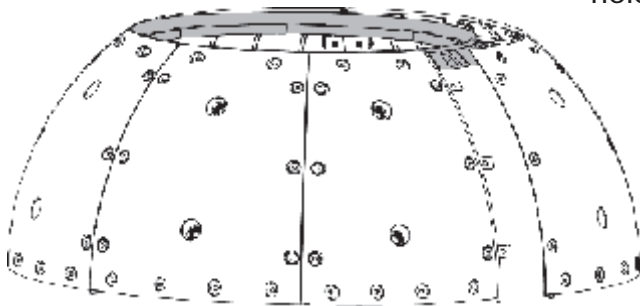

Continue to line up the holes in the panels with the holes in the collar and place rivets to hold in place. **ONLY** attach half of the panels to the collar in this step.

C

Go back to the sides and slide the side tabs into the slots in the last panel and hold in place with three rivets. Finish lining up the holes in the panels with the collar and placing rivets to hold in place.

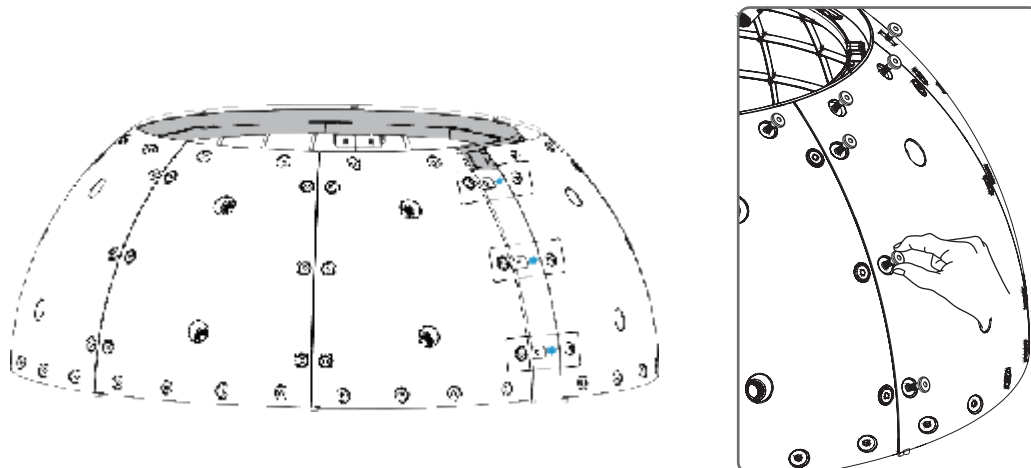

Step 4: Assemble One Half Sphere (Continued)

D

Place two S8 pins in the center of the two rivets in the top of each panel. Hammer the pins until flush and the collar is secured to the panels.

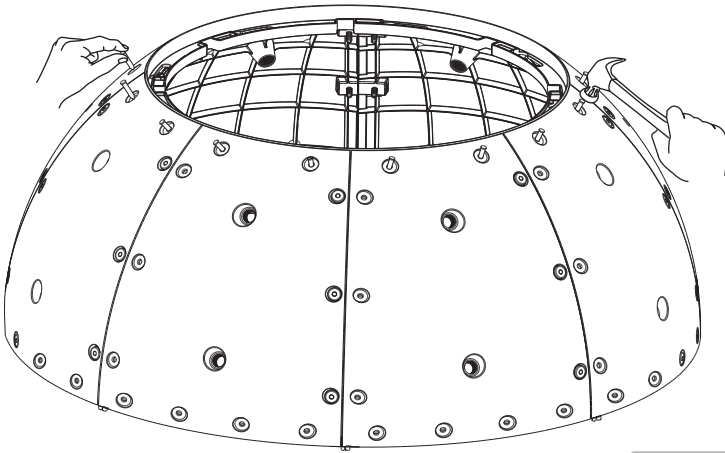

NOTE: Hammer pin until it is flush with the top of the rivet and the rivet is flush with the hole in the panel.

E

Place S8 pins in the center of the three rivets along the left side of each panel and hammer until flush.

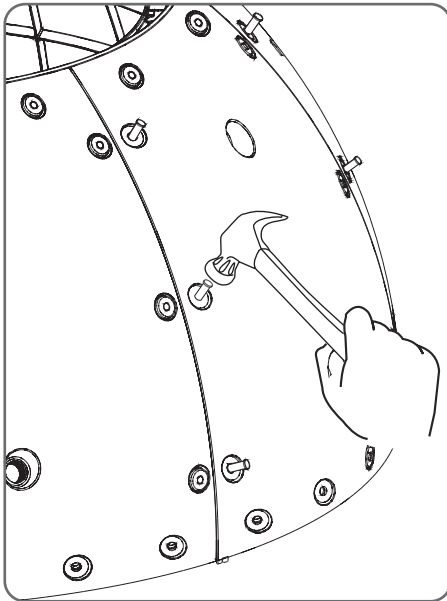

NOTE: Hammer pin until it is flush with the top of the rivet and the rivet is flush with the hole in the panel.

F

Turn the half sphere over.

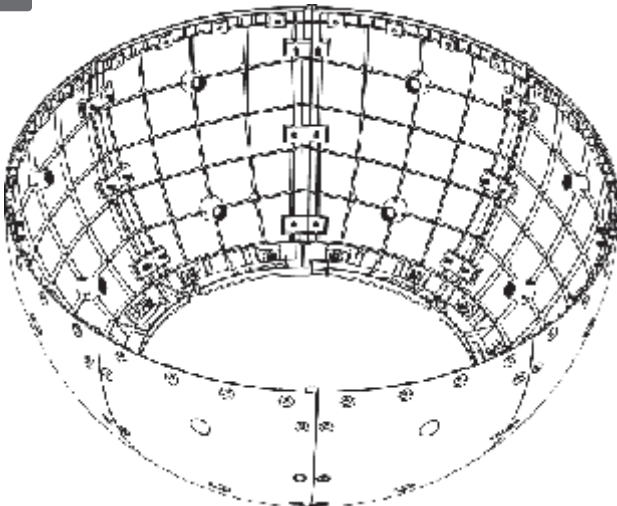

Step 5: Install Air Tubes

Components:

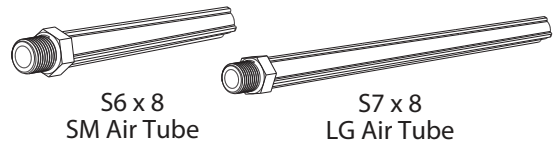

A

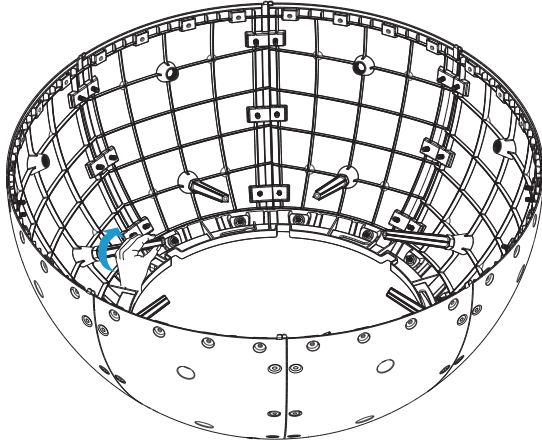

With the large opening of the half sphere up, screw eight S6 SM air tubes along the inside near the collar.

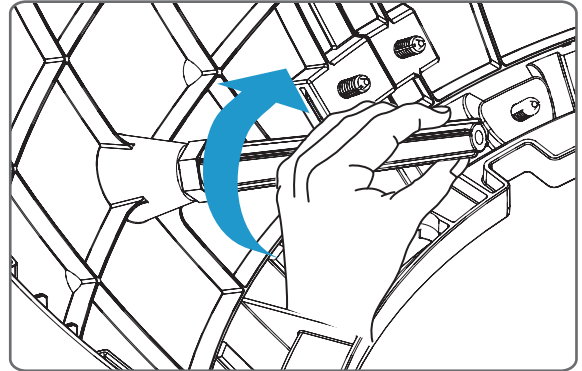

B

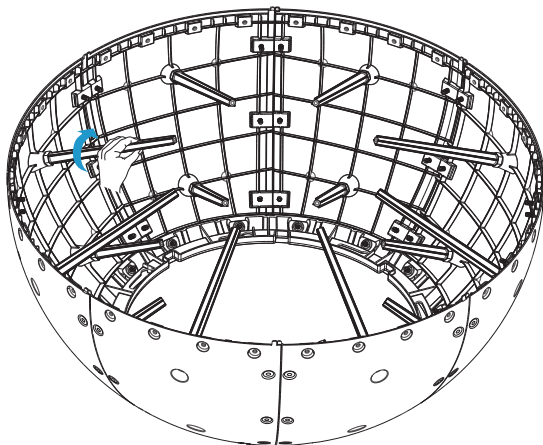

Screw eight S7 LG air tubes along the inside.

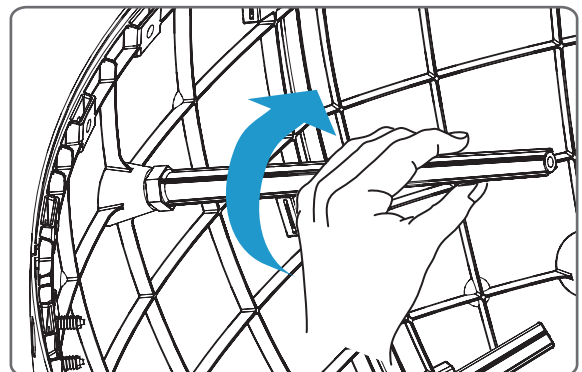

Step 6: Assemble Other Half Sphere

Repeat Steps 2 through 5 to assemble the other half sphere.

Components:

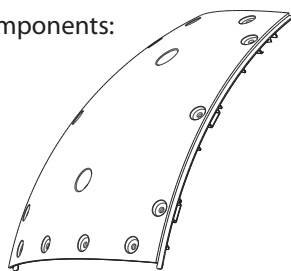

S1 x 8
Sphere Panel



S6 x 8
SM Air Tube



S7 x 8
LG Air Tube

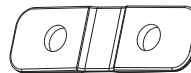

S4 x 24
Green Side Tabs

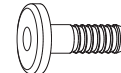

S2 x 64
Rivets

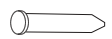

S8 x 64
Pins

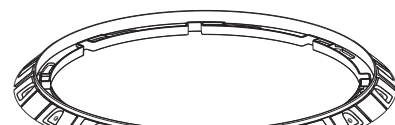

S5 x 1
Collar

Step 7: Assemble Center Ring

Components:



CR1 x 4
Center Ring



CR2 x 4
M5 Screw



CR3 x 4
M5 Nut

A

Lay the four CR1 center ring pieces in position.

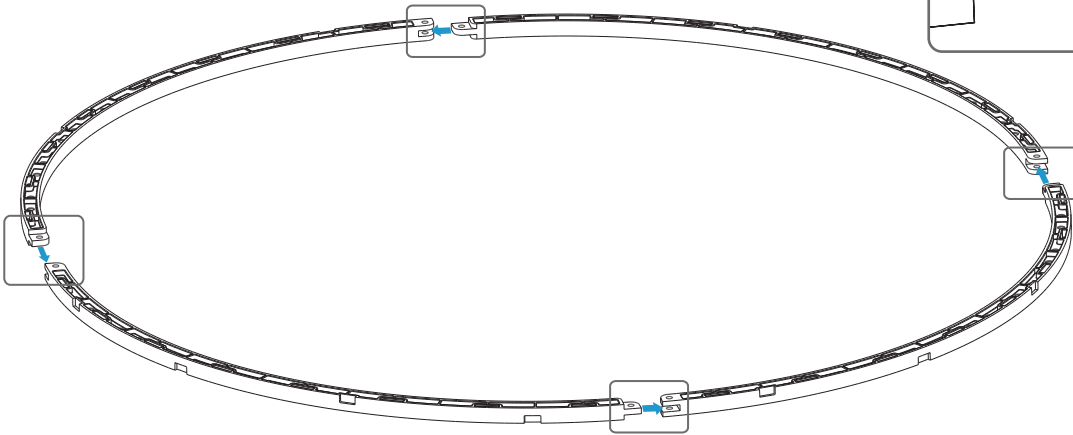

B

Fit the ends of each piece together, lining up the holes. Using a Phillips screwdriver, secure the pieces together with a CR2 screw and a CR3 nut.

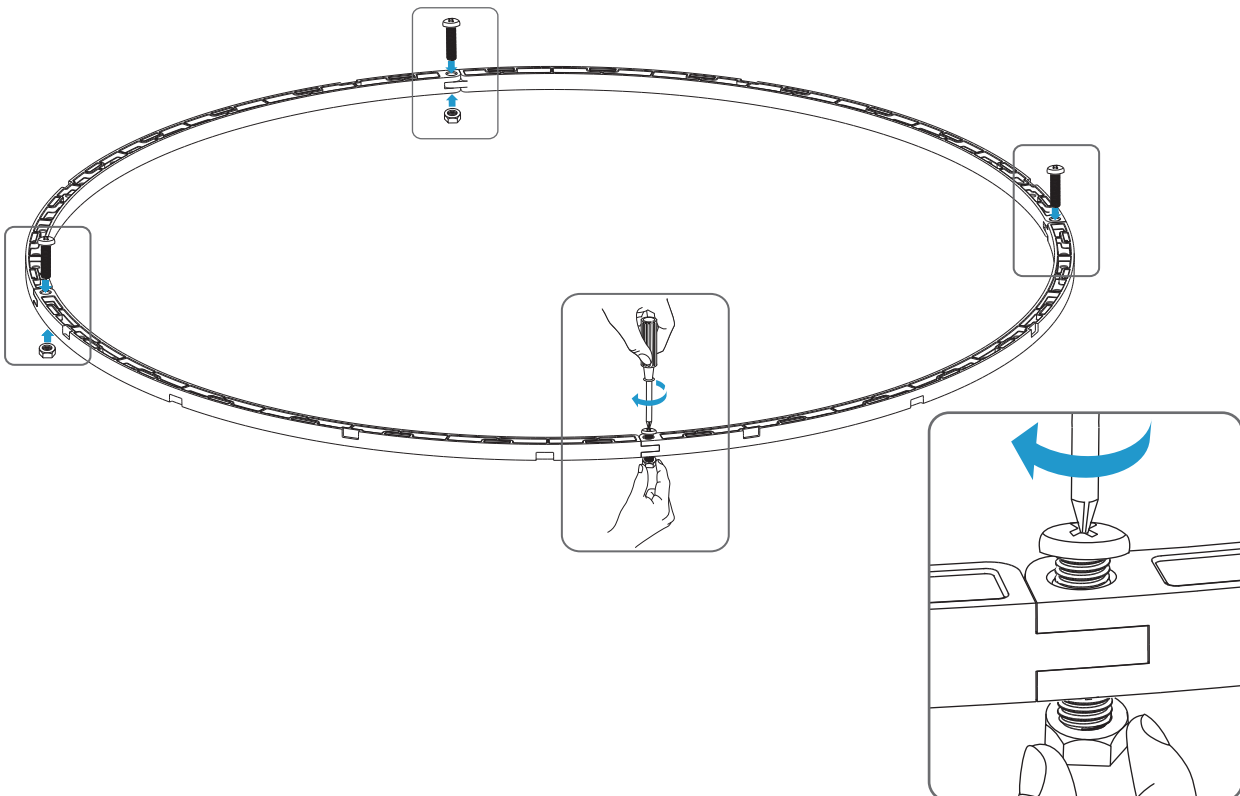

Step 8: Install Center Ring

Components:

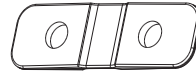

S3 x 32
White Mid Tabs

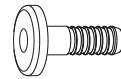

S2 x 32
Rivet

A

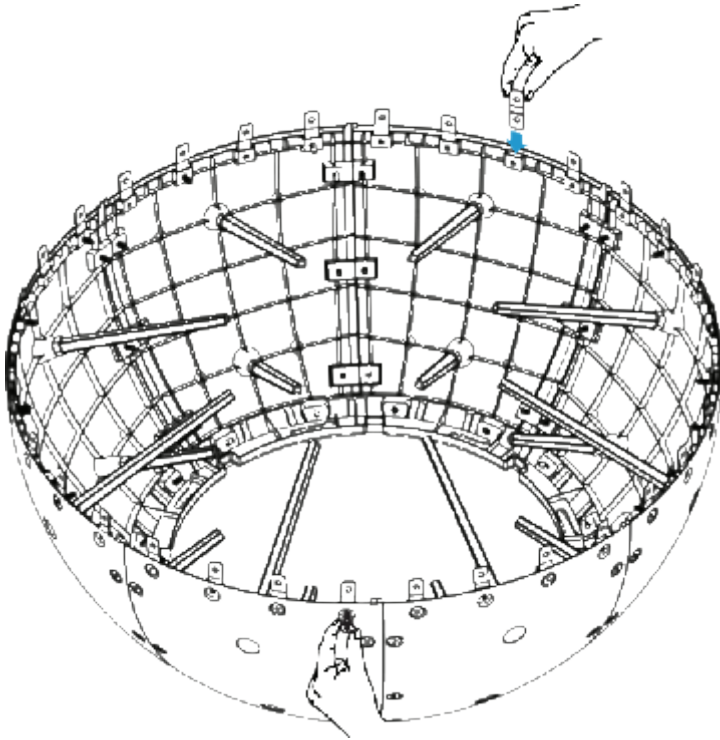

Place white mid tabs into slots in panels in one half sphere.

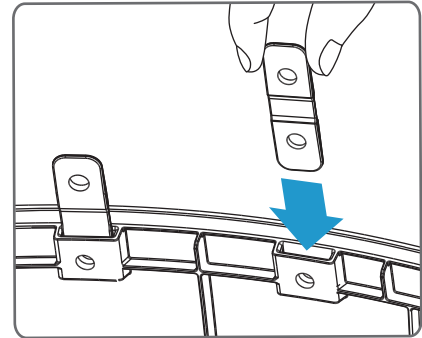

Place rivets into holes in mid tabs and panels to hold tabs in place.

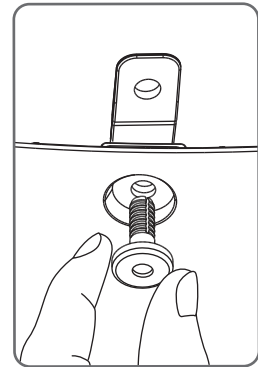

NOTE: You will hammer S8 pins into rivets in Step 9C.

B

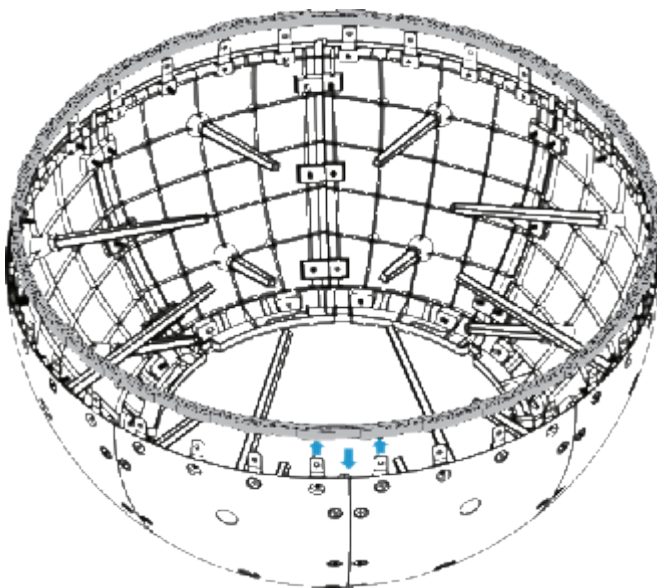

When placing center ring, turn ring so that all indents on the side line up with the seam where two panels are joined.

All white mid tabs fit through openings in the center ring.

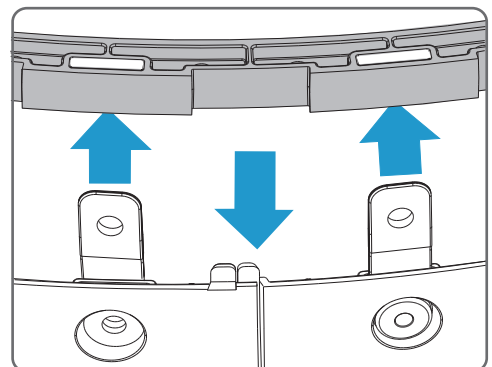

Position the center ring so the indents on the side line up with the seams where the panels are joined together. Make sure the white mid tabs fit through the openings in the center ring.

Step 9: Attach Top Sphere

Components:

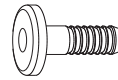

S2 x 32
Rivets

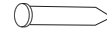

S8 x 64
Pins

A

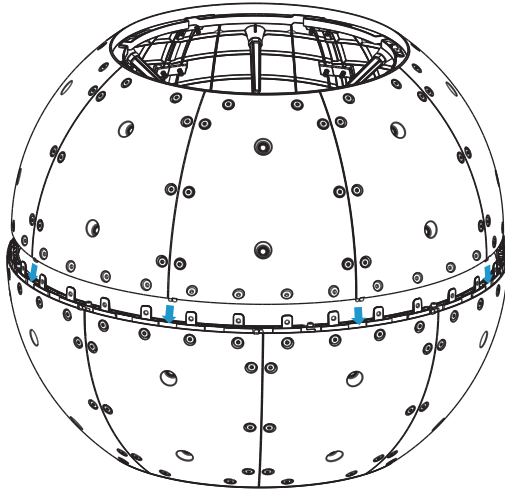

Place top half of sphere so the seams match up with the indents in the center ring.

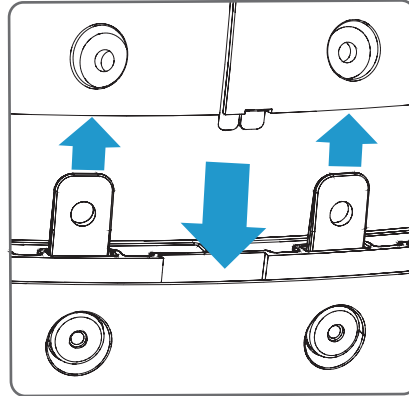

Position top half sphere so the indents on side of center ring align with the seams where the panels are joined together. Make sure white mid tabs fit into slots in the panels along lower edge of half sphere.

B

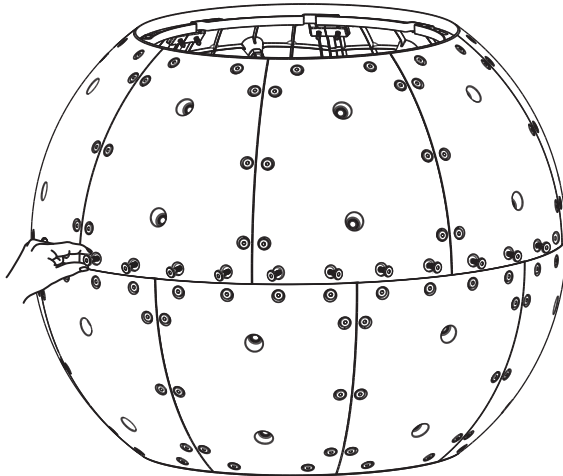

Hold in place with rivets.

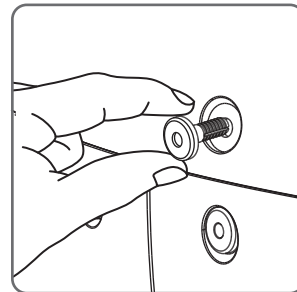

C

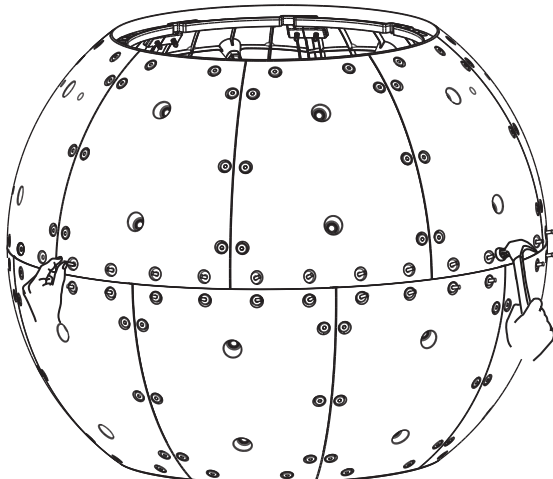

Secure all rivets by hammering pins into place. Make sure you hammer the pins until they are flush with the top of the rivets.

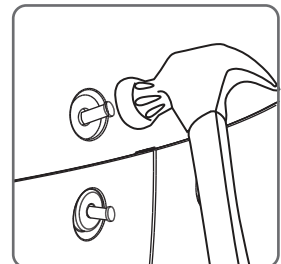
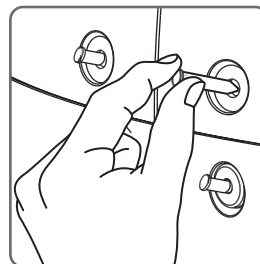

Step 10: Install Lids

Components:

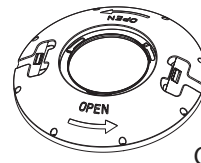

L1 x 2
Outer Lid



L2 x 2
Inner Lid



L3 x 1
Key

A

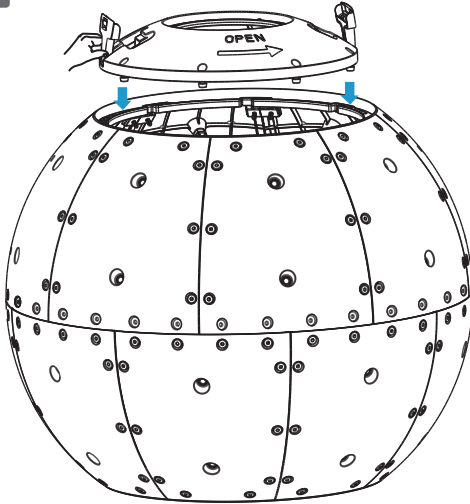

You **MUST** lift the handles on each side of the outer lid to install to the sphere. Lining up pegs inside the lid with large hole in the openings in the collar, set the lid into the collar and turn clockwise until the pegs reach the end of the openings. Lower the handles to lock in place.



You **MUST** lift the handles on the outer lid to install to sphere. **DO NOT LIFT** sphere using the handles.

View from Inside

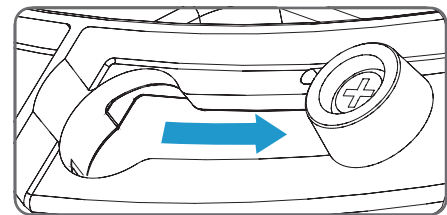

Pegs on outer lid slide to the end of the opening in collar.

B

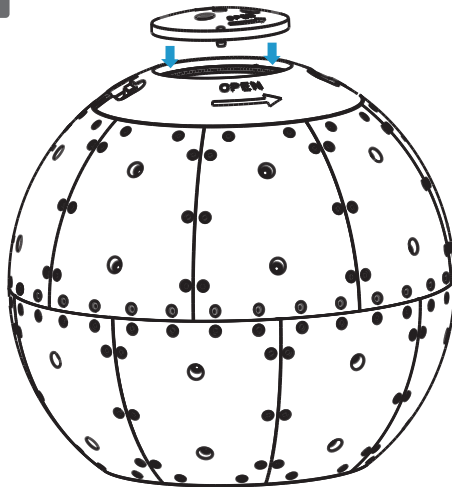

Lining up pegs inside the inner lid with large holes in the outer lid, lower the lid into place. Use three fingers to turn clockwise to close the lid.

NOTE: If the cover does not turn easily, use a Phillips screwdriver to loosen the screws on the pegs inside.

C

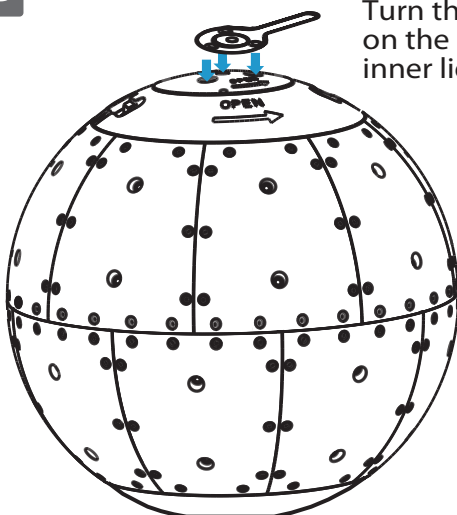

Turn the sphere over and repeat step A and B to install the cover on the other end. Use the included key or your hand to turn the inner lid counter-clockwise and lift to open.

To remove rubber plug in the center of the inner lid to drain liquids, remove inner lid from outer lid. From inside, pinch rubber plug together and push through the hole in center of inner lid. Put the rubber plug in a safe place, until you are ready to put it back in.

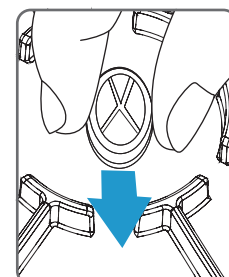
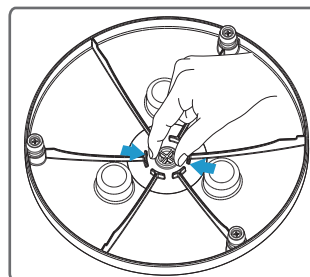

Standard Base Assembly

Step 1: Unpack Standard Base

Unpack the standard base for your Ecomposter and make sure you have the following components. If you are missing any components, please contact Customer Service at (800) 293-2923.

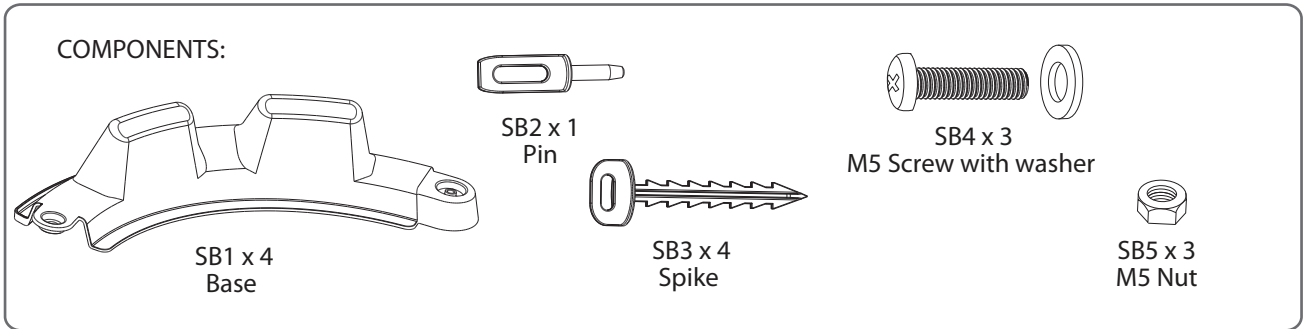

Step 2: Assemble Standard Base

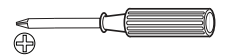

TOOLS NEEDED:
Phillips Screwdriver

A

The standard base had been designed to easily open and close, allowing the Ecomposter sphere to roll inside for storage. Place the four SB1 base parts next to each other. Fit the left side of one piece into the right side of the piece to the left of it.

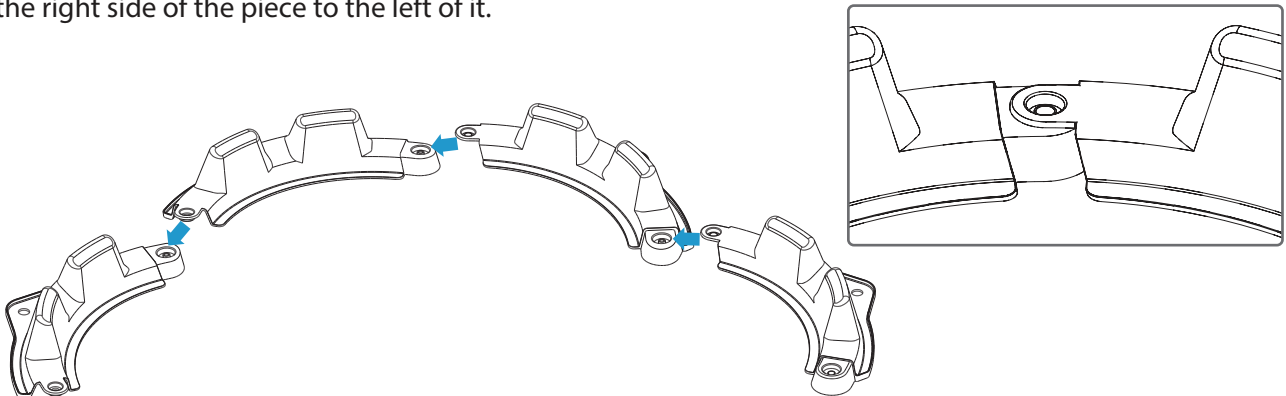

B

Use a SB4 screw with washer and SB5 nut to connect the base pieces at three sides. Tighten using a Phillips screwdriver.

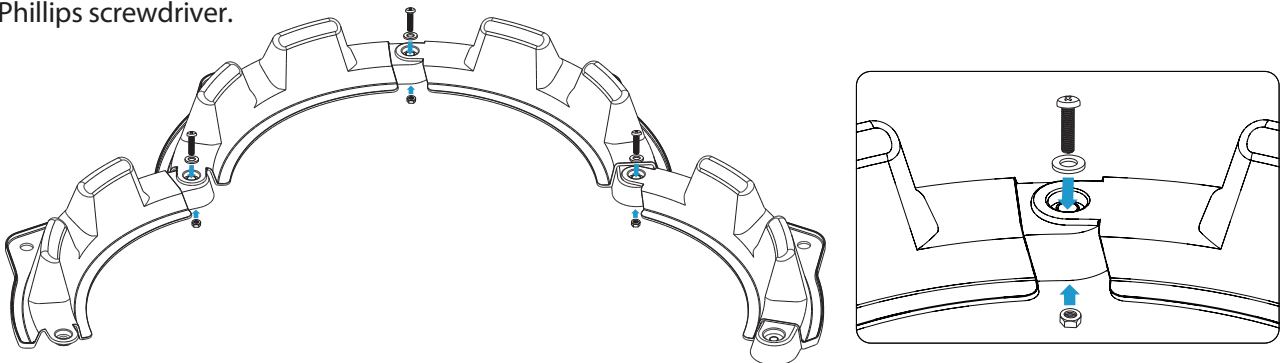

NOTE: Do not tighten the screws completely. Tighten the screws only enough so that base pieces are held together but the position can still be adjusted.

Step 2: Assemble Standard Base (Continued)

C

Find a place in your yard to set up the base. Position the four base pieces so the last two pieces fit together forming a circle. Use the SB2 pin instead of a screw to hold the base closed. Push two SB3 spikes into holes in outside rim of the back two base pieces securing the base to the ground.

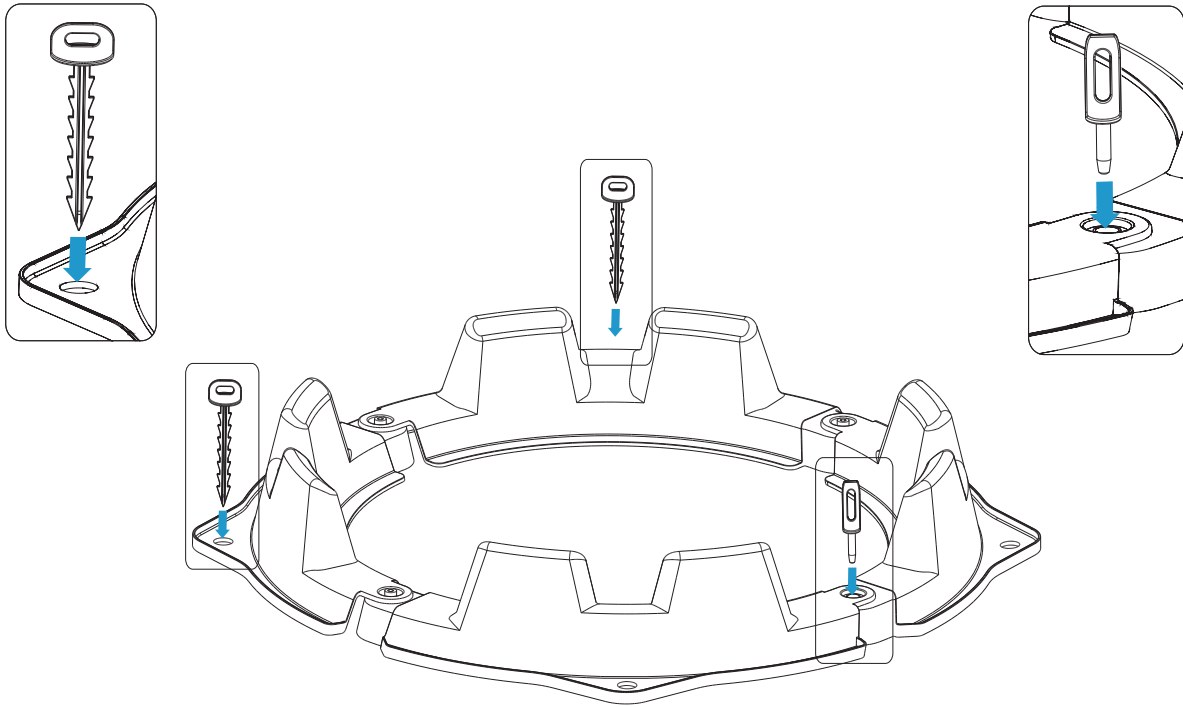

D

To use the base, remove the SB2 pin that holds the base closed. Move the front base pieces away from each other, creating an opening to roll the Ecomposter into the center of the base. Close the base and replace SB2 pin to secure. Place the remaining two SB3 spikes into the holes in outside rim of the front base pieces to hold the base firmly in place with the Ecomposter sphere inside.

IMPORTANT: The standard base is designed to store the Ecomposter when not in use. Do NOT rotate the Ecomposter while it is inside the standard base. Remove the sphere to rotate.

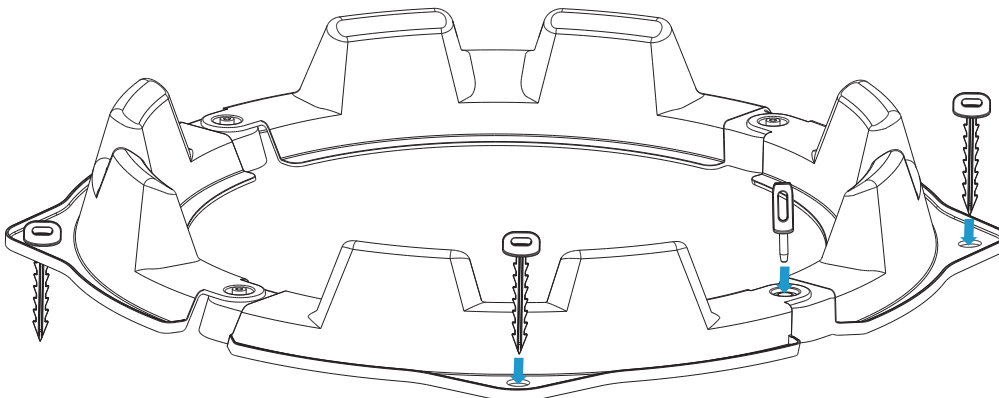

Using Your Ecomposter

Thank you for purchasing your Ecomposter and optional base. We hope it provides you with many years of enjoyment. Please read this User Guide to get the most out of your Ecomposter. Contact us with any questions at customerservice@ecomposter.net or call (800) 292-2923.



IMPORTANT: When full, the Ecomposter sphere is heavy. Place the sphere on the optional base to prevent it from moving. Place the base on smooth, level ground. The Ecomposter is not a toy. Make sure the lids are secure before rotating the sphere. **DO NOT LIFT** the sphere using the handles. Place your fingers in the holes in the sides of the sphere to lift. The handles are used to lock the outer lid into place.

About the Ecomposter Design

The unique Ecomposter sphere and patented air induction system is designed to speed up the composting process. The Ecomposter design optimizes the four key components to composting: heat, moisture, mixing and time.

How the Ecomposter Works

The sphere, with the lowest surface/volume of any shape, prevents heat loss while the dark green color attracts heat, promoting faster decomposition. The 360 degree rotation randomly blends material, keeping the compost moist and improves the mixing, aeration and decomposition process.

The large and patented air induction tubes provide an influx of oxygen into the center of the compost material, maintaining an optimal moisture level. As the sphere rotates, the air tubes break up and mix newly added materials with older materials.

How to Use the Ecomposter

The Ecomposter sphere is designed with a large outer lid to add or remove larger materials and an inner lid for smaller amounts. Both use secure locking systems. Use the handles on the outer lid to lock it in place. Use the key to tighten the small inner lid. A rubber plug in the center of the inner lid can be easily removed to drain leachate, the liquid that forms during the decomposition process, to use for your garden. Both lids are on either axis of the sphere for easy access. Before rotating the sphere, make sure all the lids are closed tightly and the rubber plug is firmly in place. See Step 10 in the assembly manual for more detail.

Before You Begin

Select a site for your Ecomposter and optional base on level ground, with good airflow, access to water and partial shade in the summer and good sun in the winter.

The basic makeup of your initial material will determine both the speed and effectiveness of the decomposition process. These materials also establish the nutrient content of the finished compost. Do not try to make compost with one ingredient.

You will be adding materials in percentages. We recommend finding a bucket or cup to use as a measuring gauge. The composting process will take between 4 to 6 weeks depending on the ratio of materials, the moisture, heat and mixing schedule. Plants lose between 50 and 75 percent of their volume in composting, so a great deal of plant material can be processed effectively.

It is important to balance the mixture of brown and green materials. Use equal parts by volume of dry and green plant materials in the overall mix. Mix grass clippings with other materials before adding. Grass mats easily and prevents water from moving through the mass. When adding easily compacted materials (such as ashes, fresh cut grass or sawdust) mix in coarser materials first.

Breaking up or shredding materials you plan to add to your compost will decompose more quickly. Adding more volume at once will also speed up the process. If you are adding material more gradually, be sure to stop adding materials to the Ecomposter to give the material time to finish decomposing.

What Materials to Compost

Add a combination of materials. The ratio of fresh green to dead brown materials will affect the amount of time it takes to make compost. Although adding more green may speed up the time, you will need at least 25 percent brown material. We recommend beginning by adding 50 percent brown to 50 percent green. If you are adding large amounts of material at once, add part of it, close the lid and turn the sphere. Open it again to add more.

Green Materials (Nitrogen)	Brown Materials (Carbon)	DO NOT Compost
Uncooked fruit and vegetable waste Coffee grounds and tea bags Egg shells (rinsed and crushed) Peanut shells Garden Waste Plant trimmings Fresh grass clippings (cut within 24 hours) Hair trimmings Fresh farm manure	Dead leaves Dead garden waste Sawdust and wood shavings Black and white newspaper Tissue paper Shredded paper and cartons Wood ashes	Pet waste Cooked food Bones Meat, Fish or Dairy Sauces, Oil or Fat Diseased plants Chemicals or pesticides Branches, twigs, redwood, Pine needles or treated wood

Monitor Your Compost

It is important to maintain a balance of green and dry materials, monitor the temperature, smell, moisture level of your materials and to turn the sphere a quarter turn daily.

Temperature

Place your hand in the center of the compost to test the temperature. If the center is warm or hot the process is working well. At temperatures of 140-160°F most pathogens and weed seeds are destroyed.

Both moisture and nitrogen will affect the temperature. If your mixture is dry, add some water to raise the temperature. If the materials are moist, add an activator, blood meal or farm manure.

Moisture

The microorganisms work best with approximately 50 percent moisture. Too much moisture means organic waste won't decompose. Too little moisture will kill the bacteria. Compost should feel moist, but not soaking wet, like a wrung out sponge. If the compost is wet, or smells like ammonia, add some dry material. If the mixture is dry, lightly spray it with water from a garden hose.

Aeration

Rotate your Ecomposter any direction daily to ensure proper aeration. The microorganisms need oxygen to breakdown the compost materials.

When the Compost Is Done

Finished compost should look, feel and smell like rich, dark soil. You should not be able to recognize any of the items you put in there. Finished compost is usually less than half the volume of the materials you started with, but it's much denser.

Apply finished compost to your garden about 2-4 weeks before you plant, giving the compost time to integrate and stabilize within the soil.

Composting Tips

Help start a new compost pile with blood meal, cottonseed meal, well-aged manure they are rich in nitrogen and help "fire-up" the microbes responsible for breaking down organic matter into compost.

If you are filling your Ecomposter every two or three weeks, we recommend getting a second Ecomposter.

Establish a composting bucket in your kitchen. This will help limit the number of trips needed to the Ecomposter.

The use of activators can get slow compost heated up faster.



Ecomposter Sphere and Standard Base

One Year Warranty

System Trading Corporation, STC, warrants the Ecomposter and optional base against defective materials and workmanship, while under normal use and service, to the original purchaser, for one (1) year from the date of delivery. This warranty is not transferable.

STC will replace any defective part, or the entire unit if necessary.

This warranty does not apply to damage caused by misuse, improper use, assembly, application or neglect.

This warranty gives you specific rights and you may have other rights which vary from state to state.

Keep this information with your important records. Please go to www.ecomposter.net to register your Ecomposter today.



Systems Trading Corporation
450 7th Avenue, Suite 2809, New York NY 10123
Phone: (800) 239-2923 Email: customerservice@ecomposter.net