

RadioShack

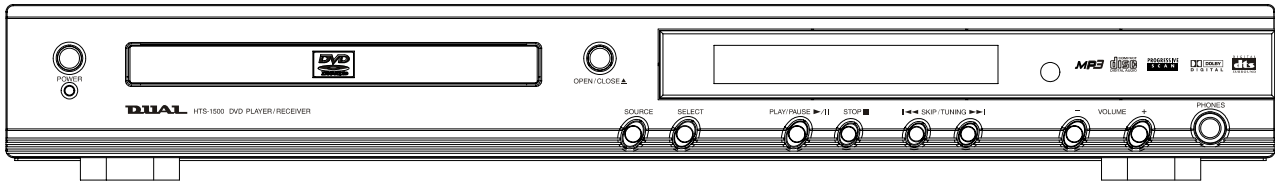

31-5023 OWNER'S MANUAL

Warning

WARNING: To prevent fire or shock hazard, do not expose the unit to rain or moisture.



CAUTION: To avoid electrical shock, do not open the cabinet. There are no user serviceable parts inside. Refer servicing to qualified personnel only.



This symbol is intended to alert the user of the presence of uninsulated "dangerous voltage" within the product's enclosure that may be of sufficient magnitude to constitute a risk of electric shock to persons.



This symbol is intended to alert the user of the presence of important operating and maintenance (servicing) instructions in the literature accompanying the appliances

WARNING: Any adjustments made to this unit may alter the performance and can result in hazardous radiation exposure.

- Do not attempt to clean the lens.
- Refer servicing to qualified personnel only.

IMPORTANT

CAUTION: This appliance contains a low powered laser device and is classified as a CLASS 1 LASER product. The following caution label is located on the rear panel



To ensure continued safety do not remove any covers or attempt to gain access to the inside of the product.

WARNING: The laser beam used in this unit is harmful to the eyes. Do not attempt to disassemble the cabinet. Refer servicing to qualified personnel only.

This product incorporates copyright protection technology that is protected by method claims of certain U.S. patents and other intellectual property rights owned by Macrovision Corporation and other rights owners. Use of this copyright protection technology must be authorized by Macrovision Corporation, and is intended for home and other limited viewing uses only unless otherwise authorized by Macrovision Corporation. Reverse engineering or disassembly is prohibited.

NOTE: This equipment has been tested and found to comply with the limits for a Class B digital device, pursuant to Part 15 of the FCC Rules. These limits are designed to provide reasonable protection against harmful interference in a residential installation. This equipment generates, uses, and can radiate radio frequency energy and, if not installed and used in accordance with the instructions, may cause harmful interference to radio communications. However, there is no guarantee that interference will not occur in a particular installation. If this equipment does cause harmful interference to radio or television reception, which can be determined by turning the equipment off and on, the user is encouraged to try to correct the interference by one or more of the following measures:

- Reorient or relocate the receiving antenna.
- Increase the separation between the equipment and receiver.
- Connect the equipment into an outlet on a circuit different from that to which the receiver is connected.

Important safety information

FOR YOUR SAFETY, READ AND RETAIN ALL SAFETY AND OPERATING INSTRUCTIONS. HEED ALL WARNINGS IN THIS MANUAL AND ON THE UNIT.

POWER SOURCE

To avoid any malfunctions of the unit, and to protect against electric shock, fire or personal injury, please observe the following :

- This system has been designed to work with 120-volt AC current. Connection to a line voltage other than that may create a safety and fire hazard and may damage the system. If you are unsure of the type of power supply to your home, consult your local dealer or power company.
- Hold the plug firmly when connecting or disconnecting the power cord to the wall outlet.
- Do not run power cords under rugs or carpets or place heavy objects on them.
- Damaged or deformed power cords are hazardous and should be replaced immediately by a qualified service technician.

LOCATION

- Air vents are provided in the cabinet to prevent excessive temperatures inside the unit. Do not place this unit in closed spaces, cover it, or otherwise block the vents.
- Do not place this unit in direct sunlight, or near heat sources.
- Keep this unit away from strong magnetic objects.
- Do not use the unit in a car. The operation can not be guaranteed.
- Place the unit in a horizontal position, and do not place anything heavy on it.

CARE

- Do not insert or drop anything into this unit through the air vents as this could cause serious damage, possibly resulting in fire.
- Do not place any object containing water or other liquids on this unit. In the event that liquid should enter the cabinet, unplug this unit immediately and contact the retailer or service center immediately.
- Do not remove the cabinet. Touching parts inside the cabinet could result in electric shock and damage to the unit.
- Do not put any foreign objects on the disc tray.

Nonuse Periods

- When the unit is not being used, turn the power off.
- When left unused for a long period of time, the unit should be unplugged from the household AC outlet.

Condensation

Moisture may form on the pickup lens in the following conditions:

- Immediately after a heater has been turned on.
- In a steamy or very humid room.
- When the unit is suddenly moved from a cold environment to a warm one.
- If moisture forms inside this unit, it may not operate properly. In this case, turn on the power and wait about one hour for the moisture to evaporate.

Volume control

- Do not turn up the volume while listening to a portion with very low level input or no audio signal. The speaker may be damaged when a peak level portion is played.

CLEANING

- Unplug the unit before cleaning.
- When the system gets dirty, wipe it with a clean, soft cloth. If necessary, wipe it with a soft cloth, slightly dampened with mild soapy water, then a fresh cloth with clean water. Wipe dry immediately with a dry cloth.
- Never use benzene, aerosol cleaners, thinner, alcohol or any volatile cleaning agent.
- Do not use abrasive cleaners, as they may damage the finish.
- Avoid spaying insecticide near all components.
- Your speakers require minimal maintenance under normal use. The cabinet may be cleaned using a damp cloth or a mild, non-abrasive cleaner. To clean the grille, first remove it from the speaker, then brush lightly with a soft brush or use a vacuum on its lowest setting. Do not attempt to clean the actual drivers.

SERVICE

- Do not open the cabinet of any components. There are no user-serviceable components in this product. Opening the cabinets may present a shock hazard, and any modification to this product will void your guarantee.
- Do not attempt to service the unit yourself. If water or any metal objects such as paper clips, wire or staples accidentally fall inside, disconnect the unit from the power source immediately, and consult an authorized service center.
- Please refer any service to the nearest service center.

Introduction

Thank you for choosing SABA. SABA specializes in state-of-the-art technology and elegant styling designed to provide many years of enjoyment. This product is provided with an immense array of features. We recommend reading this manual thoroughly before proceeding.

CUSTOMER RECORD

The model and serial number of this product are located on the back panel. Record the serial number in the space provided below to retain as a permanent record of your purchase. This will aid in the event of theft or loss.

Model Number:

Serial Number:

Contents

Warning

Important safety information

Introduction

Customer record

Contents

Getting started

Unpacking

Cautions on installation

Discs

Disc terminology

Disc handling

Function overview

Front panel

Rear panel

Remote control unit

Connections

Speaker system connection

Antenna connections

TV and optional component connections

Basic setup

Initial settings

Using the setup menu

TV display setting-selecting the aspect ratio

Selecting the on screen display (OSD) language

Downmix setting

Using test tone mode

Center delay setting

Rear delay setting

Selecting the dynamic range

Selecting the audio language

Selecting the disc menu language

Selecting the parental control level

Returning to the original factory default settings

Playback functions

DVD disc playback

Slow-motion playback

Search to locate a point quickly

Selecting the searching speed

Repeat playback

A-B repeat playback

Program playback

Selecting a start point by chapter or time code

Viewing disc information

Playing VCD discs with PBC (playback control)

Playing VCD2.0 discs with PCB

Playing MP3 discs with PCB

Special functions

Picture zoom

Angle selection

Selecting the subtitle language

Setting the audio language

Setting the audio mode for karaoke

Selecting The output signal (Progressive/Interlaced)

Setting the Pr/Pb/Y mode

Other functions

Operating the radio

Storing radio stations

Manual preset

Retrieving preset stations

Listening to an external source

Using the sleep timer

Limited warranty

Troubleshooting

Specifications

Features

- DVD player with built-in DTS and Dolby Digital decoders, supporting Dolby Pro Logic, Virtual Surround and Progressive Scan.
- Built-in six channel amplifier system.
- AM/FM digital tuner.
- Compatible with DVD, SVCD, VCD1.1, VCD2.0, MP3, CDR, CDRW and CD-DA (audio) discs.
- User friendly DVD navigation functions.
- Multi-color fluorescent front panel display and on screen display menu.
- Full function ergonomic remote control.

Manufactured under license from Dolby Laboratories. "Dolby", "AC-3", "Pro Logic" and the double-D symbol are trademarks of Dolby Laboratories. Confidential Unpublished Works. ©1992_1997 Dolby Laboratories, Inc. All rights reserved.

Manufactured under license from Digital Theater System, Inc. US Pat. No. 5,451,942 and other worldwide patents issued and pending. "DTS" and "DTS Digital Surround" are trademarks of Digital Theater System, Inc. ©1996 Digital Theater Systems, Inc. All rights reserved.

Getting Started

Unpacking

The carton and shipping materials used to protect your new SABA Home Theater System during shipment were specially designed to cushion it from shock and vibration. We suggest that you save this carton and packing materials for use in shipping if you move, or should the system ever needs repair.

Your Home Theater System includes everything you need to connect the system to your television and begin enjoying the cinema experience in your own home

Check that you have the following items:

- One DVD player/receiver
- One six-piece loudspeaker system which includes:
 - Five color coded satellite speakers:
(Two front speakers with red/black leads, one center speaker with blue/black leads, and two rear speakers with grey/black leads).
 - One Subwoofer Speaker (color coded green) with attached 15-foot two-conductor color coded (green/black) connection wire for connecting to the receiver's subwoofer output.
- One 5-foot triple-lead patch cord with red, white and yellow connectors for connecting the composite video and analog audio outputs from your receiver to your television.
- Five two-conductor, color-coded speaker connection wires (two red/black 20-foot, one blue/black 20-foot and two grey/black 40 foot) for connecting the receiver to the four satellites and center speakers.
- One FM antenna cable
- One AM loop antenna
- One full function ergonomic remote control
- Owner's Manual and warranty

Cautions on installation

- Please refer to the instruction manuals of any components to be connected to this unit.
- Do not turn on the power or plug any of the components into the wall outlet until all connections are secure.
- Be sure to unplug the unit from the AC wall outlet when connecting audio source equipment or speakers. This prevents any possibility of sending audio or transient signals to the speakers and damaging them.
- When not in use, we recommend that you leave the power for your unit turned off. If you experience interference during normal television viewing, simply turn the DVD player deck off. This is not a malfunction of the unit or the television.
- This unit is a precision device that is constructed using extremely accurate technology. Soiling or friction affecting the pickup lens or disc drive can impair the image quality. At the worst, neither video nor audio will be played back. To obtain optimum picture quality, the players should be checked (cleaning and replacement of some parts) every 1,000 hours. Note that this period varies depending on the environment (temperature, humidity, dust, etc.) in which the player is used
- Do not connect this unit directly to a VCR. The playback picture will be distorted because DVD video discs are copy protected.

Discs

The types of discs listed below will play on this SABA DVD Player Deck.

The corresponding logos are indicated on the disc label or jacket:

- DVD video discs
- DVD audio discs
- VCD (Video CD) discs
- SVCD discs
- CD-DA (CD audio) discs
- MP3 audio discs
- CDR and CDRW data discs



The following discs will not be play:

- Photo CD, CD-G, CD-Extra, CD-ROM, and DVD-ROM discs are not designed to play with this system.
- You cannot play illegally produced discs.
- You cannot play disc that are dusty, soiled, scratched or marked with fingerprints.
- DVD discs with a Region Code other than the one for which this player is set.

NOTE: This player is designed and manufactured for compatibility with Region Management Information that is encoded on most DVD discs. This player is designed only for playback of discs with Region Code 1, or for discs that do not contain Region Code information. If there is any other Region Code encoded on a disc, it will not play.

Disc terminology

• Titles and chapters (DVD-video discs)

DVD video discs are divided into several large sections called "titles" and smaller sections called "chapters". Numbers are allotted to these sections. These numbers are called "title numbers" and "chapter numbers".

For example:

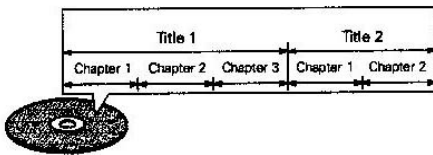

• Tracks (audio and video CD discs)

Audio and video CD discs are divided into sections called "tracks".

Numbers are allotted to these sections. These numbers are called track numbers.

For example:

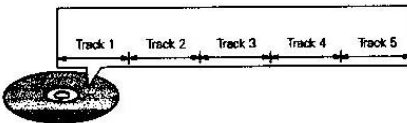

• Playback control (video CDs)

Video CD discs with the words "playback control" on the disc or jacket are equipped with a function for displaying menus on the TV monitor. Use the menus to select the desired position, display information, etc. in a dialogue fashion.

This function is referred to as "PCB mode" for this system.

Copyright: It is prohibited by law to reproduce, rent or play discs in public without the consent of the copyright holder.

Copyright protection: This DVD player supports Macrovision copyright protection technology. DVD discs that contain a copy protection code are prohibited from being copied and the copies will not play normally.

Note: KODAK and Picture CD are registered trademarks of the Eastman Kodak Company.

Disc handling

Holding discs

- To keep the disc clean, handle the disc only by its edges. Do not touch the surface.



Fingerprints or dirt on the disc may lower sound and picture quality or cause breaks in playback.

Cleaning discs

- Before playing, clean the disc with a soft clean cloth.
- Wipe the disc gently from the center outwards. Do not wipe in a circular motion.



- Do not use solvents such as benzene, thinner, commercially available cleaners or anti-static spray intended for vinyl record albums.

Handling discs

- Do not get fingerprints, grease, or dirt on discs.
- Be especially careful not to scratch discs when removing them from their cases.
- Do not bend discs.
- Do not heat discs.
- Do not enlarge the center hole.
- Do not write on the labeled side of the disc.

Loading discs

- Only load one disc at a time. Loading a disc on top of another may result in damage or scratch the discs.
- Do not place anything but discs in the disc tray.
- Do not try to close the disc tray when the disc is not installed properly.

Storing discs

- After playing, store the disc in its case to protect them from dust, scratches and warping.
- Do not expose discs to direct sunlight or heat sources such as hot air ducts. Do not leave discs in cars parked in direct sunlight as there can be a considerable rise in temperature inside the car.
- Do not write or use tape on the label side of the discs.
- Be careful not to drop or bend the disc.

Function overview

Front panel

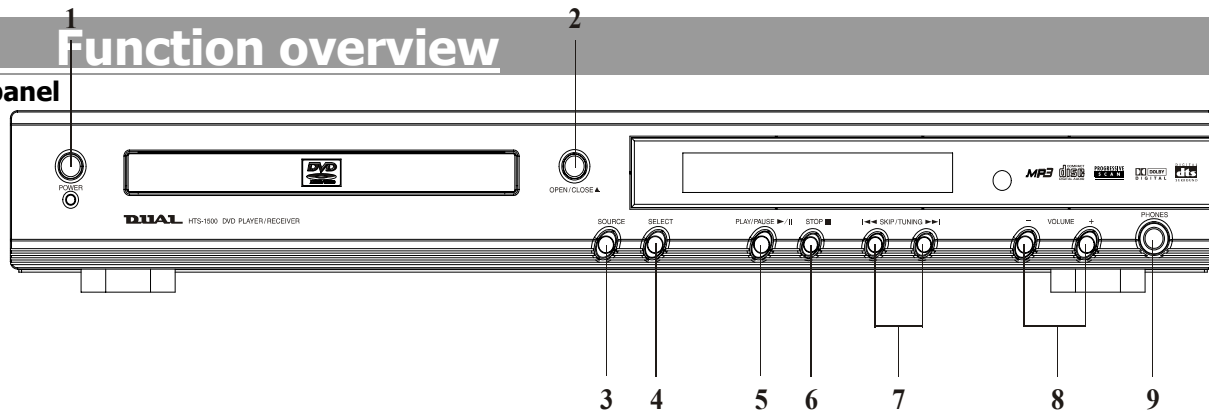

1. POWER

To turn the unit on or off. When the system is turned on, the unit will go to the mode it was set in before the power was turned off.

2. OPEN/CLOSE

To open/close the disc tray.

3. SOURCE

Select source: DVD, FM, AM or AUX (auxiliary component).

4. SELECT

To select the audio channel to view or adjust its level.

5. PLAY/PAUSE ▶ / II

To start or temporarily stop playback.

6. STOP

Stops playback of a disc and clears the stored program.

7. ⏪ SKIP/TUNING ⏩

In tuner mode, press to tune to a higher or lower radio frequency. For automatic tuning, press and hold it for more than 2 seconds. In DVD mode, press to play a disc in fast forward or reverse modes.

8. VOLUME +/-

Increase or decrease the master volume level.

9. PHONES

Use to connect the headphones.

Function overview

Rear panel

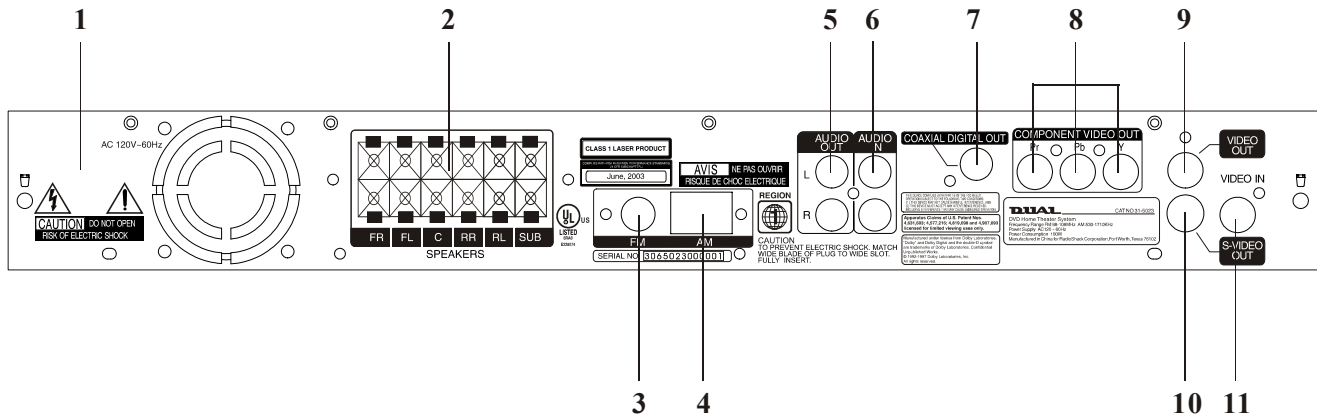

1. AC Power Cord

Connects to an AC 120V/60Hz wall outlet.

2. SPEAKER output terminals

Connect to the supplied speakers as color coded.

3. FM antenna terminal (75 ohm)

Plug the FM antenna into the FM terminal of the main unit.

4. AM antenna terminal

Plug the AM antenna into the AM terminal of the main unit.

5. AUDIO OUT (L/R)

Connects to an optional receiver or amplifier.

6. AUDIO IN

Connects to the audio output of the television or VCR.

7. COAXIAL OUT

Connects to an optional receiver equipped with 5.4 digital COAXIAL inputs.

8. VIDEO OUT (Pr/Pb/Y)

Connects to the television or monitor with component video (progressive) 480p input.

9. VIDEO OUT (composite)

Connects video input to the television.

10. S-VIDEO OUT

Connect to the television with S-Video input.

11. VIDEO IN

Connects video output to the VCR.

Function overview

Remote control unit

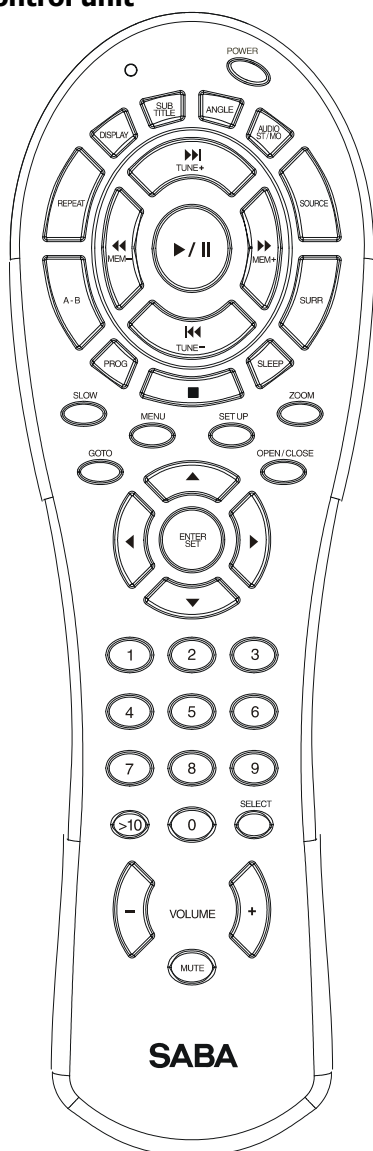

1. POWER

Turns the system power on or off.

(Note : Power switch on main unit must be "ON".)

2. SOURCE

Selects the component you want to use.

3. SURR

Selects a desired speaker listening mode.

4. SLEEP

Activates the sleep timer.

5. STOP

Stops disc playback and clears the stored program.

6. PROGRAM

Stores tracks for program play.

7. A-B

Programs a section to play repeatedly.

8. REPEAT

Use to playback titles/chapters/tracks repeatedly.

9. DISPLAY

Switches the item displayed on the TV screen or / and on the front panel display.

10. SUBTITLE

Selects a desired language for the subtitles while playing a DVD.

11. ANGLE

Changes the angles while playing a DVD.

12. AUDIO (ST./MONO)

Selects the audio channels for sound (2.1 to 5.1) and the desired audio language when playing a DVD.

Switches between monaural or stereo mode during FM stereo reception.

13. « MEM »

In tuner mode, press to select the preset stations. While playing a disc, press to select the next or previous title, chapter or track.

14. « TUNE »

In tuner mode, press to tune to a higher or lower station frequency. For automatic tuning, press and hold it for more than 2 second.

Press to play a disc in fast forward or reverse mode.

Function Overview

- 15. ▶ / || PLAY/PAUSE**
To start or temporarily stop playback.
- 16. ZOOM**
Zoom in the playing pictures.
- 17. SETUP**
Displays or exits the SETUP menu.
- 18. MENU**
Switch the PBC function to On or Off. (Video CD 2.0)
- 19. SLOW/MEM**
Presets the radio station.
Activate the slow-motion play mode while playing a DVD.
- 20. OPEN/CLOSE**
To open/close disc tray.
- 21. GOTO**
Selects a start point to play.
- 22. ◀ / ▶ / ▲ / ▼, ENTER/SET**
Move the cursor to select and execute the items or settings.
- 23. Number buttons**
Select the items or setting.
- 24. MUTE**
Mutes the sound.
- 25. VOLUME +/-**
Increases or decreases the master volume level or the selected channel level.
- 26. SELECT**
Selects the audio channel to view or adjust its level.

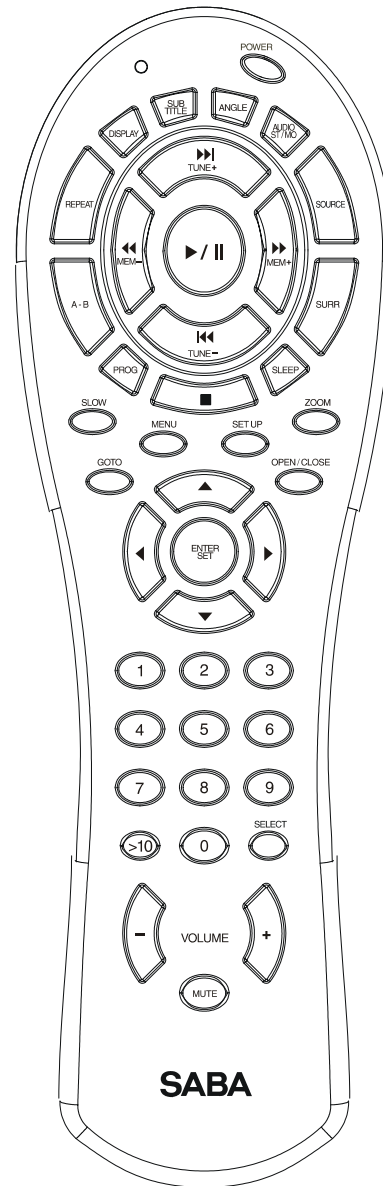

Connections

Speaker system connection

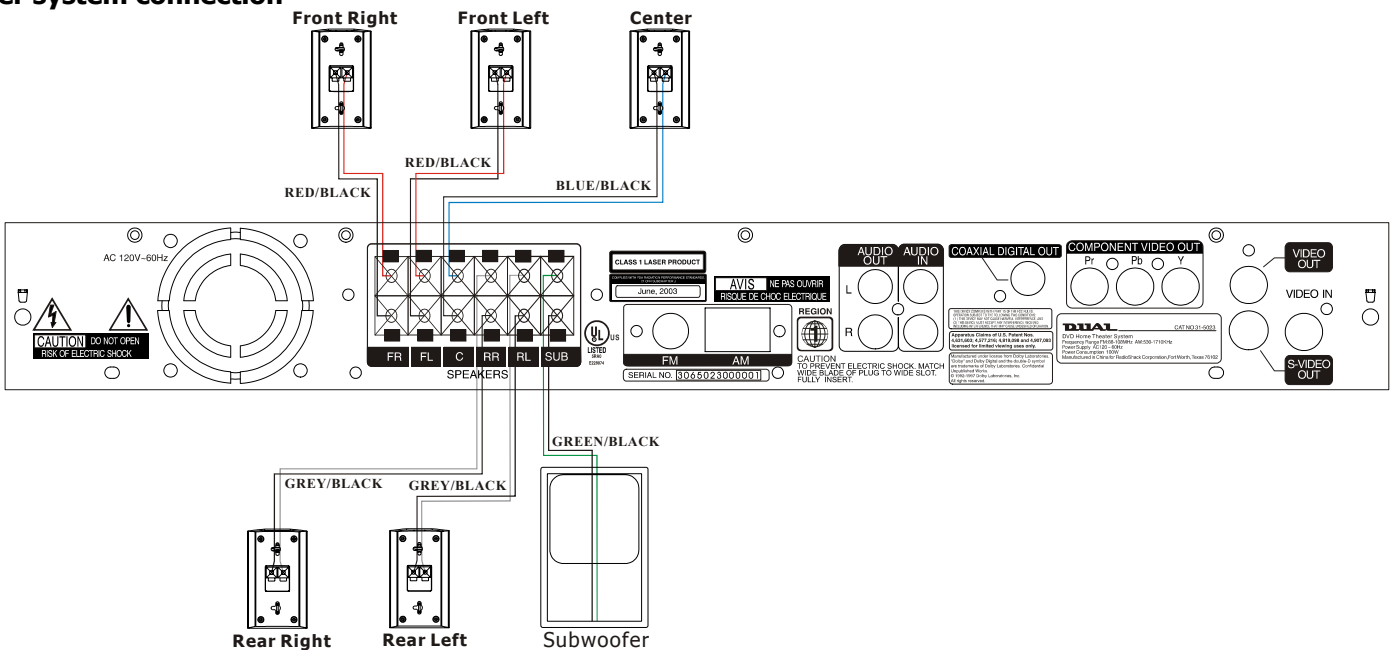

The speaker system is color coded for easy setup. Each speaker has two color coded spring type connectors located at the rear of its case. You will be connecting each speaker to the player using with corresponding color coded speaker cables. Simply insert the black part of each speaker cable into the black connector marked (-) and the corresponding color (red, blue, grey or green) part of each cable to the other corresponding color connector (+).

- Connect the red/black front left speaker to the red/black FL terminals.
- Connect the red/black front right speaker to the red/black FR terminals.
- Connect the blue/black center speaker to the blue/black C terminals.
- Connect the grey/black surround left speaker to the grey/black SL terminals.
- Connect the grey/black surround right speaker to the grey/black SR terminals.
- Connect the green/black subwoofer speaker to the green/black SUB terminals.

NOTE: After connecting all speakers, check the connections using the test tone feature described on page __. This feature will help you confirm that all speakers are working properly. Please note that the sound coming from the subwoofers will often be softer than that coming from the speakers.

To avoid short-circuiting the speakers

Make sure the stripped end of each speaker cord does not touch another speaker terminal or the stripped end of another speaker cord.

Examples of poor speaker connections

- Stripped speaker cord is touching another speaker terminal.

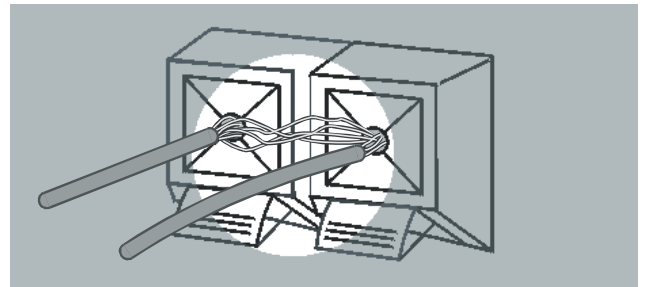

- Stripped cords are touching each other due to excessive removal of insulation.

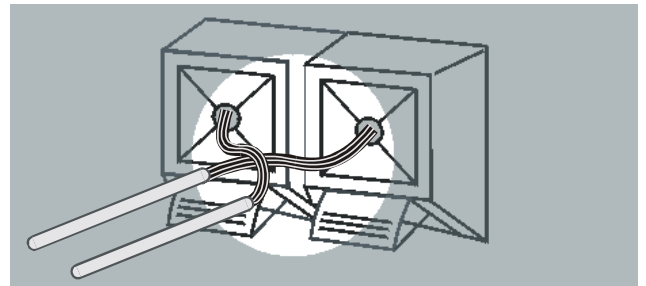

Note: Be Sure to match the speaker cord to the appropriate terminal on the component: + to + and - and -. If the cords are reversed, the sound will be distorted and will lack bass.

Antenna connections

Connect the supplied AM/FM antennas for listening to the radio.

- Connect the AM antenna to the AM terminals.
- Connect the FM antenna to the Fm terminals.

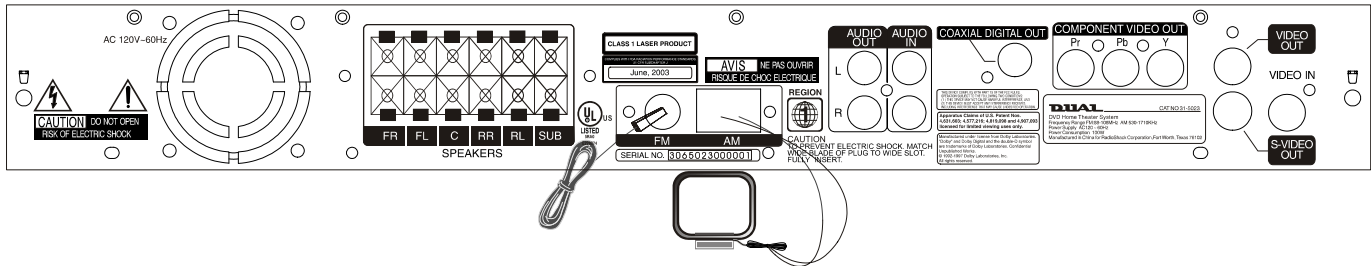

Connections

TV and optional component connections

- Use the supplied audio cables to connect **AUDIO IN** jacks to the corresponding AUDIO OUT jacks on the television, VCR or other audio/visual components.
- Use the supplied audio cables to connect **AUDIO OUT** jacks to the corresponding AUDIO IN jacks on the television, tape or CD recorders.
- Use the cables to connect **VIDEO OUT (Pr/PB/Y)** jacks to the corresponding component video inputs on the television or monitor.

NOTE: Some televisions or monitors are equipped with component video inputs capable of reproducing a progressively scanned 480p video signal. Connection to these inputs allows you to view the highest quality pictures with high resolution.

- Use the 75 ohm coaxial cable to connect **COAXIAL OUT** jacks to the corresponding Coaxial type digital audio input on an amplifier equipped with a Dolby Digital decoder.
- Use the video cable to connect the **VIDEO OUT** jack to the Video input jacks on the television.
- Use the S-Video cable to connect the **S-VIDEO OUT** jack to S-Video input jack on the television.
- Use the video cable to connect the **VIDEO IN** jack to the Video output on the television or VCR.

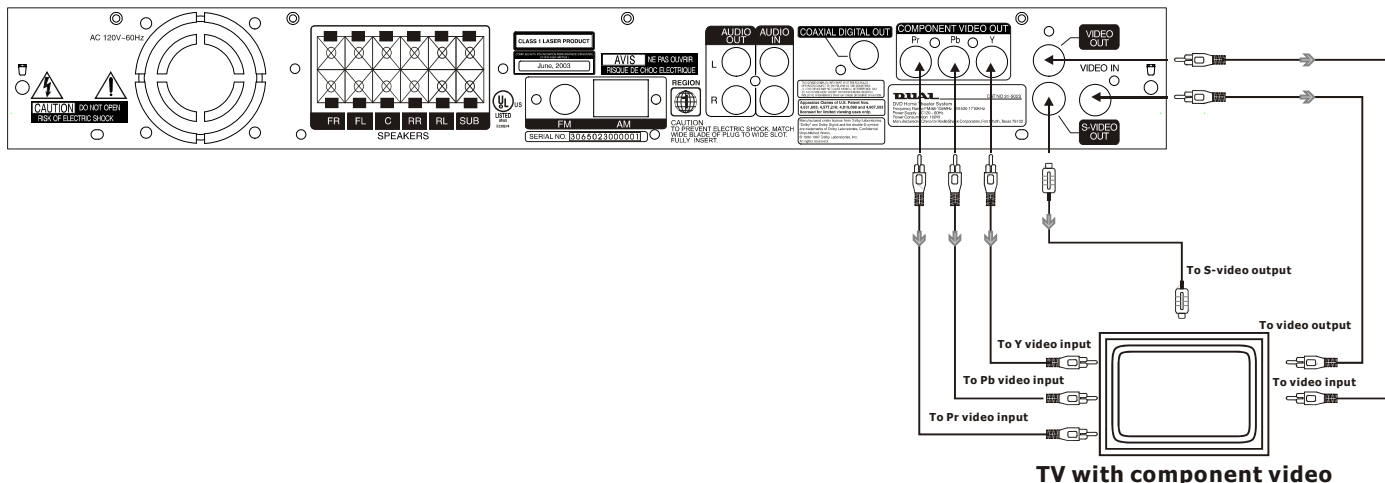

Basic Setup

Setting up the surround sound system

You must connect all the speakers and setup the system properly in order to enjoy the digital cinema experience at home.

Note: Use the test tone mode to check the balance level and connections of your speakers. (Refer to page ____).

Position

For the best possible surround sound, normally all the speakers other than the subwoofer should be placed the same distance from the listening position.

This system allows you to place the center speaker up to 4 feet closer **B**, and the rear speakers up to 16 feet closer **C** to the listening position. The front speakers can be placed from 3 to 45 feet **A** from the listening position.

It is best to place the subwoofer near a corner to maximize the bass output.

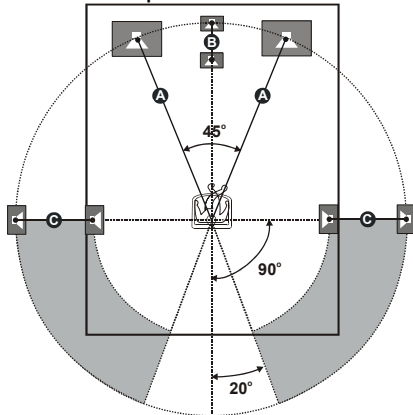

Place the rear speakers either behind or to the side of the listening position, depending on the shape of the room (as illustrated).

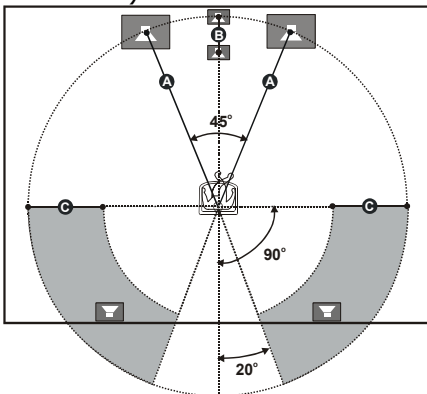

Height

The recommended height to place the center, front and rear speakers is level with your ears while in a seated position.

If necessary, the rear speakers may be placed slightly higher than the center and front speakers. Note the area labeled **C** in the diagram below:

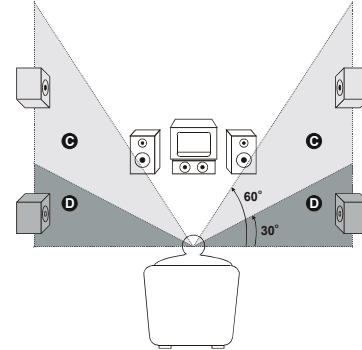

Balance

To set the channel levels, you will be adjusting the volume level on each speaker to achieve balance. Using the remote control unit, press the **SELECT** button to select a channel as follows:
 FL (front left) ⇒ CNT (center) ⇒ FR (front right) ⇒ SR (surround right) ⇒ SL (surround left) ⇒ SUB (subwoofer).

The level of the selected channel will be displayed on the television screen and on the front panel display.

Use the **VOLUME+** button to adjust the selected channel's level between 00dB and +10dB as follows:
 00DB ⇒ +01DB ⇒ +02DB ⇒ +03DB ⇒ +04DB ⇒ +05DB ⇒ +06DB ⇒ +07DB ⇒ +08DB ⇒ +09DB ⇒ +10DB.

Use the **VOLUME-** button to adjust the speaker channel's level between 00dB and -10dB as follows:
 00DB ⇒ -01DB ⇒ -02DB ⇒ -03DB ⇒ -04DB ⇒ -05DB ⇒ -06DB ⇒ -07DB ⇒ -08DB ⇒ -09DB ⇒ -10DB.

Notes:

- The default setting is 00DB. We suggest that you set you subwoofer to +05DB for better balance.
- If you do not press the **SELECT**, **VOLUME +** or **VOLUME -** button after a few seconds, the value turns off and is stored in the system.
- To adjust the master volume (the volume of all the speakers at once)** use the **VOLUME +** and **VOLUME -** buttons in normal mode.

Basic setup

Initial settings

This system is designed with a user-friendly setup menu. Use the section to take you through the system and disc setup options and recommendations.

Using the setup menu

Press the **SETUP** button on your remote control unit to display the setup menu. Use the $\blacktriangledown/\blacktriangle/\blacktriangleright/\blacktriangleleft$ buttons to select your preferred option, and press the **ENTER/SET** button to confirm a highlighted selection. To exit setup menu, press the **SETUP** button.

TV Display Setting: selecting the aspect ratio

The aspect ratio of a television is the relationship between its width and height, and it defines the shape of the picture. Television sets traditionally have an aspect ratio of 4:3. Since most DVD discs are recorded in "wide aspect ratio" formats, the picture must be adjusted to fit on your screen.

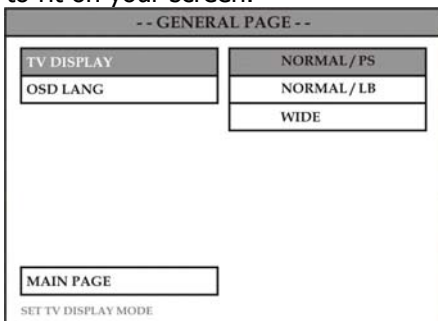

- **NORMAL/PS:** The Pan and Scan presentation crops both sides of the wide screen format to fill the standard 4:3 television screen.
- **NORMAL/LB:** The Letterbox presentation places black bars at the top and bottom portions of the screen to provide the full wide screen format of a movie on a standard 4:3 television screen.
- **WIDE :** When connecting to a wide screen 16:9 television, select this option. The unit automatically sets and outputs a recorded signal in correct aspect ratio.

Notes:

- The default setting is NORMAL/PS.
- Some DVD discs do not permit Pan and Scan mode playback and will automatically playback in Letterbox mode, and vice versa.
- Be sure to set the screen mode on your wide-screen TV to "FULL".
- If the WIDE option is selected with a standard 4:3 television, the playback picture will appear distorted (objects will look thin).

Selecting the on screen display (OSD) language

This setting is used to establish the language that will be displayed for all operations and on screen messages. To change this setting, use the setup menu, select general setup, to access the following screen:

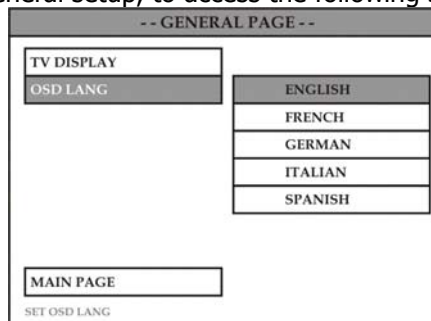

- Select one of the five available languages: ENGLISH, FRENCH, GERMAN, ITALIAN and SPANISH.
- The default setting is ENGLISH.
- If the selected language is not recorded on the DVD disc, the player will automatically default to the disc's initial language setting.

Notes:

- The default setting is LT/RT.
- If you are not getting any output from the speakers connected to this system, change the setting to LO/RO.

Selecting the listening mode

When playing DVD discs recorded in DTS 5.1 signal format, press the **SURR** button repeatedly to select: STEREO \Rightarrow DTS.

When playing DVD discs recorded in Dolby Digital signal format, press the **SURR** button repeatedly to select: STEREO \Rightarrow DOLBY DIGITAL.

When playing VCD, MP3 or CD discs, press the SURR button repeatedly to select: STEREO \Rightarrow DOLBY PRO LOGIC.

When using the auxiliary or AUX mode, press the **SURR** button repeatedly to select: STEREO \Rightarrow DOLBY PRO LOGIC.

When the system is in TUNER mode, press the **SURR** button to select STEREO (the only available choice for this mode).

DOWNMIX setting

This setting will affect the audio output signal when playing DVD discs recorded with surround multi-channel audio. To select one of the following Downmix settings, use the setup menu, select speaker settings to access the DOWNMIX menu

- LT/RT: For use with an external amplifier or television with a Dolby Pro Logic decoder.
- LO/RO: For use with a stereo amplifier/receiver or television with conventional 2-channel stereo.

Using the test tone mode

We recommend that you use the test tone mode after you have set up and connected your speakers to check the balance level and connections of each speaker.

Use the setup menu to select speaker setup, to arrive at the following screen:

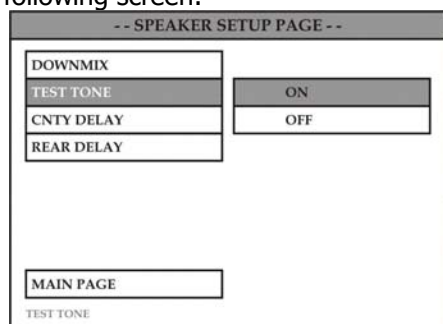

Turn this function to ON to test each speaker individually with a two second pink sound. The location of the speaker will be displayed on the television screen and the front display panel, as each speaker is being tested.

NOTE: When performing this test, it is common for the volume of the pink noise from the subwoofer to be lower than the volume of the pink noise from the center, front and rear speakers.

Center delay setting

The center delay can be adjusted in Dolby Digital mode. To change this setting, use the setup menu, select speaker setup to access the following screen:

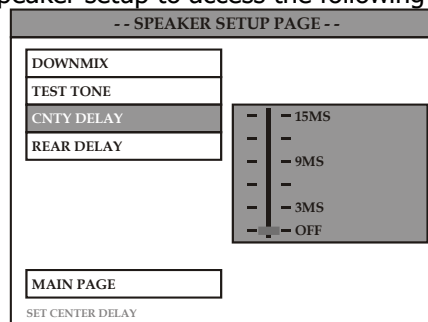

Select the desired delay time of the center speaker as follows: OFF, 3MS, 6MS, 9MS, 12MS, 15MS.

NOTE: The default setting is 15ms. We recommend that you change it to 9ms.

Rear delay setting

The rear delay can be adjusted in Dolby Digital mode. To change this setting, use the setup menu, select speaker setup to access the following screen:

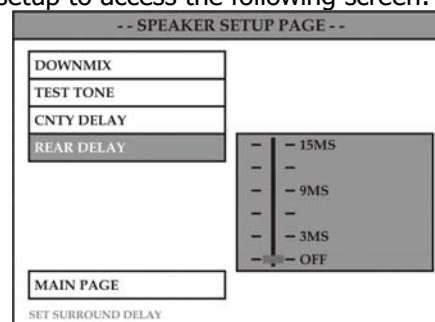

Select the desired delay time of the surround speaker as follows: OFF, 3MS, 6MS, 9MS, 12MS, 15MS.

NOTE: The default setting is 15ms. We recommend that you change it to 9ms.

Basic setup

Selecting the dynamic range

Dynamic range compression, a function used to compress the dynamic range (reproduction level range) of audio signals, can be selected for Dolby Digital mode. It is used for viewing DVD discs late at night or at other times when high volume levels are not desirable.

To adjust this setting, use the setup menu, select audio setup to access the following screen:

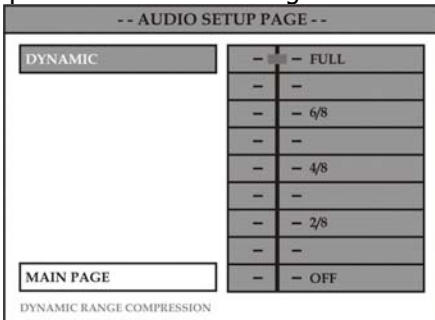

The compression options are as follows: FULL, 7/8, 6/8, 5/8, 4/8, 3/8, 2/8, 1/8, OFF.

The default setting is OFF.

Selecting the audio language

Select a desired audio language for a DVD disc that has audio data recorded in multiple-languages. To adjust this setting, use the setup menu, select preferences to access the following screen:

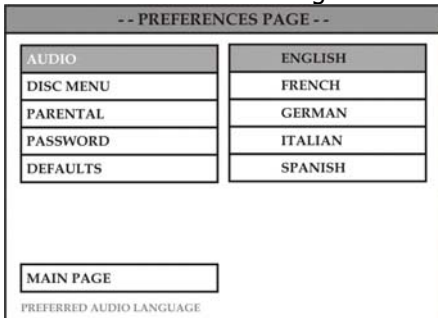

The default setting is ENGLISH.

Selecting the disc menu language

Select a desired language when playing a DVD disc that has menu data recorded in multiple-languages. To adjust this setting, use the setup menu, select preferences to access the following screen:

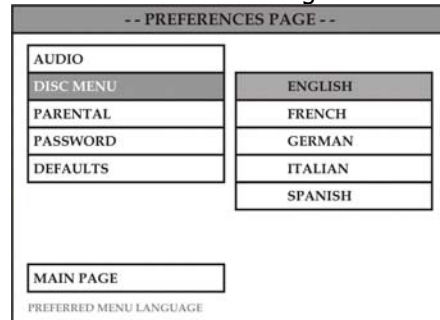

The default setting is ENGLISH.

Selecting the parental control level

This player allows parents to set a restriction level preventing the playback of certain discs.

To set this feature, use the setup menu, select preferences to access the following screen:

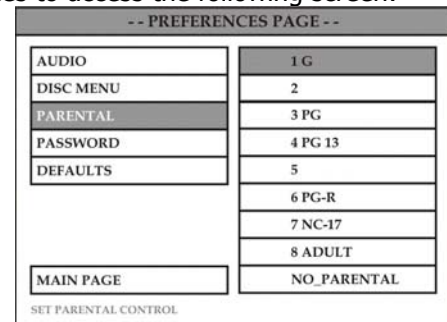

The parental lock levels are as follows: 1G, 2, 3PG, 4 PG 13, 5, 6 PG-R, 7 NC-17, 8 ADULT, NO_PARENTAL.

Notes:

- The default setting is NO PARENTAL.
- The lower the value is, the more strict the limitation.
- If the parental control level of the loaded DVD disc is lower than the level set, the screen will display "PARENTAL VIOLATION" message, and refuse to play the disc.
- The disc must be recorded with a parental lock, for this feature to function.
- Before changing the parental control level, you must enter the preset password (4-digit code) to unlock this function. If the entered password is incorrect, you will not be able to change the level.
- The default password is "9999".

Changing the parental control password

To change the parental control password use the setup menu, select preferences to access the password menu. Press the **ENTER/SET** button to enter the old password "9999". ("XXXX" will appear as you enter the numbers). When prompted to enter a new password, enter a 4-digit code and enter it again when prompted to confirm password. Press the **ENTER/SET** button once more to change the password from "9999" to the new 4-digit password you have entered.

NOTE: To avoid locking this function forever, do not lose or forget your new password.

Returning to the original factory default settings

To return all settings to the factory defaults, use the setup menu, select preferences to access the defaults menu:

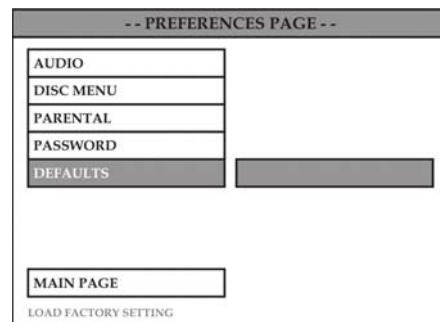

Select and press the **ENTER/SET** button to return the system to its original factory settings.

IMPORTANT: The parental control level and the password will not be reset. To avoid locking this feature forever, make note of your new password.

Playback functions

IMPORTANT :

Please note that some DVD movie discs may not have all the features described in this chapter. For example, older movies may not allow you to select multiple camera angles. Refer to the instructions or liner notes that are included with each disc to determine what features and operations are available on that particular disc.

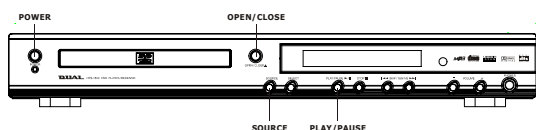

To watch a DVD disc:

1. Turn your television set's power on, and set the channel to the video input.
2. Press the **POWER** button on the front panel to turn on the main power of this system. The front panel display lights up, and the DVD logo screen appears on the television screen.
3. If the system is not in the DVD player mode, press the **SOURCE** button on the front panel or remote control to select it.
4. Press the **OPEN/CLOSE** button, and place a disc on the disc tray.

NOTE: Load the disc placing the label side face up, and using the disc tray as a guide for proper alignment. When playing a double-sided DVD disc, load it with the desired playing side face down.

5. Press the **PLAY/PAUSE** button to start playback.

Slow-motion playback

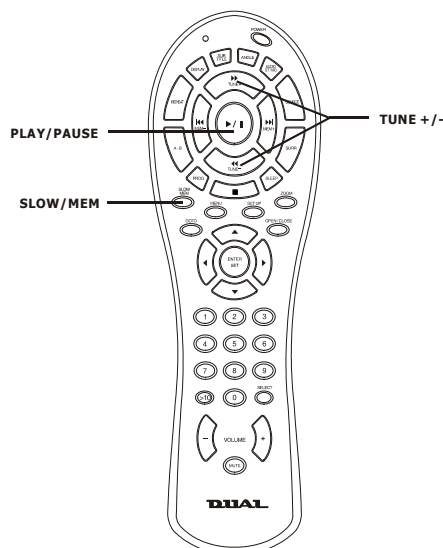

To view playback in slow-motion, press the **SLOW/MEM** button on the remote control unit during playback.

When playing DVD discs:

Press the **SLOW/MEM** button repeatedly to select the slow motion speed and direction as follows:
▶ SLOW 1/2 ⇌ ▶ SLOW 1/4 ⇌ ▶ SLOW 1/8 ⇌ ◀ SLOW 1/2 ⇌ ◀ SLOW 1/4 ⇌ ◀ SLOW 1/8 ⇌ NORMAL.

When playing CVD, SVCD or VCD discs:

Press the **SLOW/MEM** button repeatedly to select the slow motion speed as follows:
▶ SLOW 1/1 ⇌ ▶ SLOW 1/2 ⇌ ▶ SLOW 1/3 ⇌ NORMAL.

Notes :

- ▶ SLOW: Slow forward playback.
- ◀ SLOW: Slow reverse playback.
- The smaller the number, the slower the speed.
- This function is not available for CD or MP3 discs.
- On some discs, the slow-motion playback function is not available.

Playback functions

Search to locate a point quickly

While playing a disc, use the **◀TUNE** or **TUNE▶** buttons to fast forward and fast reverse, scrolling through the speeds to get back to normal play (see below) or use the **▶ / ||** button to return to the normal forward playback immediately.

Selecting the searching speed

To change the searching speed press the **◀TUNE** button for fast reverse search and the **TUNE▶** button for fast forward search.

When playing DVD or MP3 discs:

The reverse playback speed can be adjusted by pressing the **◀TUNE** button repeatedly as follows: F.BWDX2 ⇨ F.BWDX4 ⇨ F.BWDX6 ⇨ F.BWDX8 ⇨ NORMAL.

The forward playback speed can be adjusted by pressing the **TUNE▶** button repeatedly as follows:

F.FWDX2 ⇨ F.FWDX4 ⇨ F.FWDX6 ⇨ F.FWDX8 ⇨ NORMAL.

When playing CD, SVCD or Video CD discs:

The reverse playback speed can be adjusted by pressing the **◀TUNE** button as follows:

F.BWDX1 ⇨ F.BWDX2 ⇨ F.BWDX3 ⇨ F.BWDX4 ⇨ NORMAL.

The forward playback speed can be adjusted by pressing the **TUNE▶** button as follows:

F.FWDX1 ⇨ F.FWDX2 ⇨ F.FWDX3 ⇨ F.FWDX4 ⇨ NORMAL.

Notes:

- The larger the number is, the faster the searching speed.
- For CD discs, as the search reaches the end of one track, the player will begin to play the next track at normal speed.

Skip the next or previous title, chapter or tracks

Press the **◀MEM** or **MEM▶** button while playing a disc. The playback will go to the previous or next title, chapter or track.

Notes:

- When using 'repeat title, chapter or track' playback mode, press the **◀MEM** or **MEM▶** button to move to the previous or next title, chapter or track.
- When using 'repeat all tracks' playback mode, press the **◀MEM** or **MEM▶** button to move to the previous or next title, chapter or track in sequence on the same disc.

Repeat playback

Use this function to set the player to repeat individual tracks on CD or Video CD discs, chapters or titles on DVD discs, an entire disc, or all the discs loaded in the player.

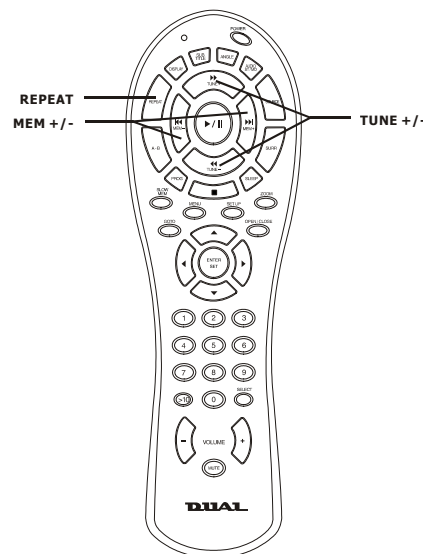

When playing DVD discs:

Press the **REPEAT** button repeatedly to select the following: CHAPTER REPEAT ⇨ TITLE REPEAT ⇨ REPEAT OFF.

When playing DVD, SVCD, CD and MP3 discs (with no folders):

Press the **REPEAT** button repeatedly to select the following: REPEAT ONE TRACK ⇨ REPEAT ALL TRACKS ⇨ REPEAT OFF.

When playing MP3 discs (with folders):

Press the **REPEAT** button repeatedly to select the following: REPEAT ONE TRACK ⇨ REPEAT ONE FOLDER ⇨ REPEAT ALL TRACKS ⇨ REPEAT OFF.

Notes:

- Use the repeat function with the programming mode to repeat tracks or chapters.
- This function is only available when playback is selected.
- When playing DVD and SVCD discs, set the PBC (playback control) mode to OFF to use this function.
- The front panel display will display **【R-CHP】** when chapter repeat mode is selected; and **【R-TIT】** when repeat mode is selected.

Playback functions

A-B repeat playback

Use this function to play a specific portion in a chapter or track repeatedly. This is useful to memorize lyrics or watch a portion of a disc over and over.

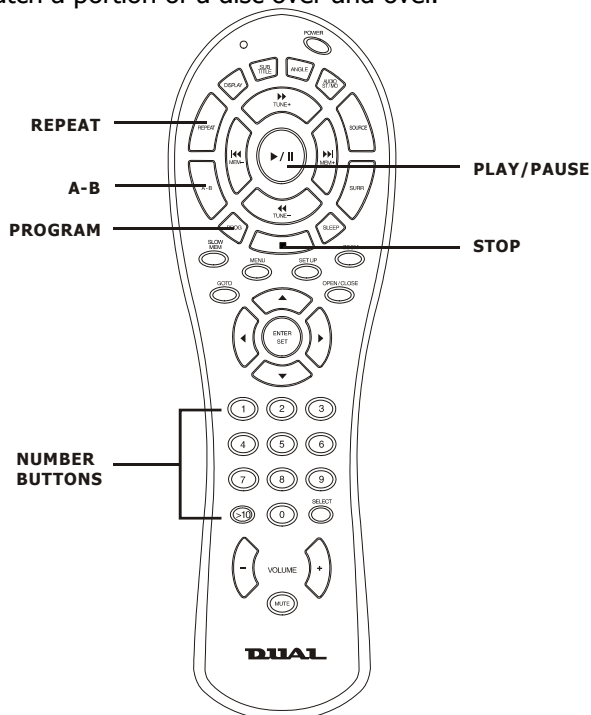

1. Press the **A-B** button at the beginning of the selection you want to repeat. The "A" indicator will be displayed.
2. Press the **A-B** button again at the end of the selection. The "A-B" indicator will be displayed, and this section will now repeat continuously.
3. Press the **A-B** button again to cancel and resume normal playback.

Notes :

- When using this function with DVD discs, both the start and end point of the repeat must be in the same title.
- To repeat a section of a disc just once, press the **A-B** button at the beginning of the section, then press **PLAY/PAUSE** button at the end. The playback will jump back to the start point.
- This function is only available when playback mode is selected.
- The A-B repeat function is canceled when you stop the playback, open the disc tray, or turn the power off.

Program playback

This function is for use with CD audio discs only. By selecting and programming the order of the tracks on a disc to be played, you can create your own program. One program can be stored in the system and contain up to 99 tracks.

Notes :

- The program function is not available in TUNER and AUX modes.
- When playing DVD and MP3 discs, the program function is not available.
- The program function is only available when the stop mode is selected.

1. Press the **PROGRAM** button to start the memory registration mode. The PROG indicator illuminates and "P00:00" will appear on the front panel display.
2. Press the **0~9** and **>10** buttons to enter the desired track number.
3. Press the **PROGRAM** button again. The disc and track number are stored in the disc program.
4. Repeat step 2 to add more items to the program list.
5. Press the **PLAY/PAUSE** button to begin program playback.
6. During the program playback, press the **STOP** button to stop program playback. Press the **STOP** button again to delete the current program and return to stop mode.

Notes :

- If you have programmed the maximum limit (99 tracks) and try to enter another track number, the "FULL" indicator will appear on the display.
- To repeat playback for the programmed tracks, press the **REPEAT** button while in the program playback mode.
- The program sequence is canceled when you press the **STOP** button twice, open the disc tray, or turn the power off.

Playback functions

Selecting a start point by chapter or time code

This player offers different ways of accessing the information on DVD or Video CD discs.

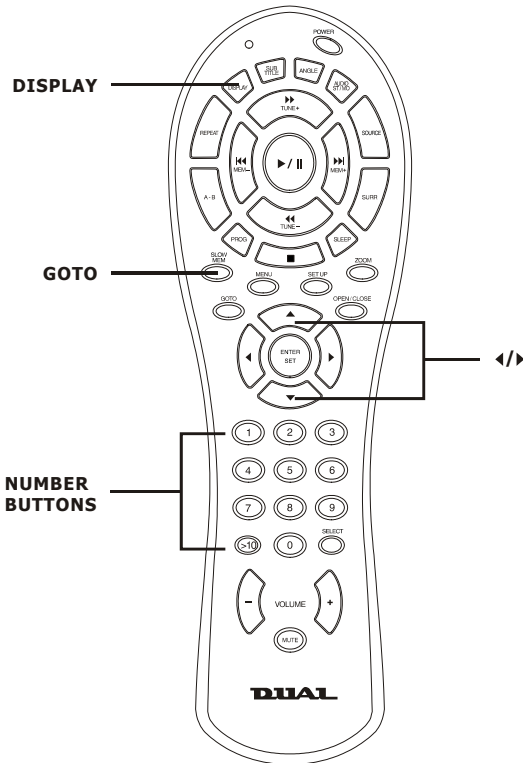

Use the GOTO button on the remote control unit to search for titles or chapters on a DVD disc, tracks on a VCD disc, or to select the time to start playback.

When playing DVD discs:

1. Press the **GOTO** button repeatedly to select: TITLE and CHAPTER ⇒ TIME MENU ⇒ OFF.
2. In the TITLE and CHAPTER search mode, press the ◀ or ▶ button to select TITLE or CHAPTER search.
3. Press number (0~9 and >10) buttons of the desired title or chapter where you would like to begin playback.

When playing VCD discs:

1. Press the **GOTO** button repeatedly to select: TIME MENU⇒OFF.
2. In the TIME MENU search mode, press the number (0~9 and >10) buttons of the specific time where you would like to begin playback.

Viewing disc information

You have the option to view current information, such as titles and chapters on DVD discs or tracks on VCD and CD discs.

When playing DVD discs:

1. Press **DISPLAY** button once to display Title number, Chapter number and Title elapsed time.
2. Press the **DISPLAY** button a second time to display Title remaining time.
3. Press the **DISPLAY** button a third time to display Chapter elapsed time.
4. Press the **DISPLAY** button a fourth time to display Chapter remaining time.
5. Press the **DISPLAY** button a fifth time to select display function off.

When playing SVCD , VCD or CD discs:

1. Press the **DISPLAY** button once to display Single Elapsed time.
2. Press the **DISPLAY** button a second time to display Single remaining time.
3. Press the **DISPLAY** button a third time to display Total elapsed time.
4. Press the **DISPLAY** button a fourth time to display Total remaining time.
5. Press the **DISPLAY** button a fifth time to select display function off.

Note: To use this function When playing SVCD or VCD discs, the PBC (playback control) mode must be set to OFF.

Playback functions

When playing an MP3 encoded CD disc:

1. Press the **DISPLAY** button once to display Single Elapsed time.
2. Press the **DISPLAY** button a second time to display Single Remaining time.
3. Press the **DISPLAY** button a third time to select display function off.

Playing VCD discs with PBC (playback control)

Some Video CD discs have PBC (playback control) menus that are displayed automatically upon playback. Use these menus to select playback options.

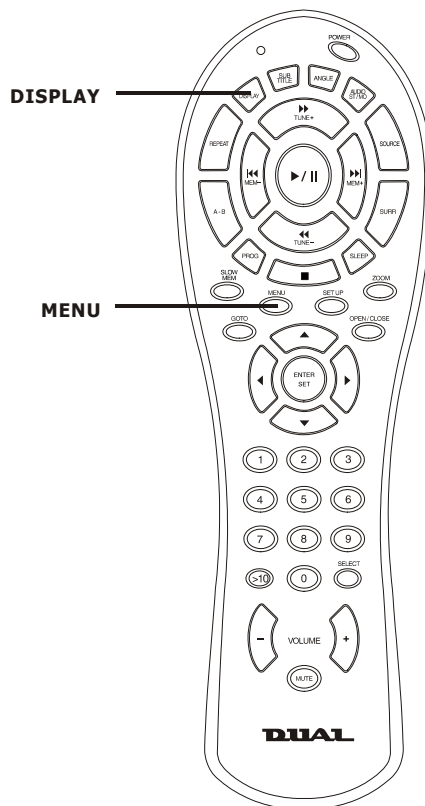

When playing VCD2.0 discs with PBC, the menus will not appear automatically. Press the **MENU** button, to view and use the menus.

When playing MP3 discs with PBC, the menus will appear automatically and will continue to appear during playback. Press the **▼/▲/▶/◀** buttons to select the desired song, then press the **ENTER/SET** or **PLAY** buttons to begin playback.

Picture zoom

This function allows you to enlarge the picture on the television screen and to pan through the enlarged image.

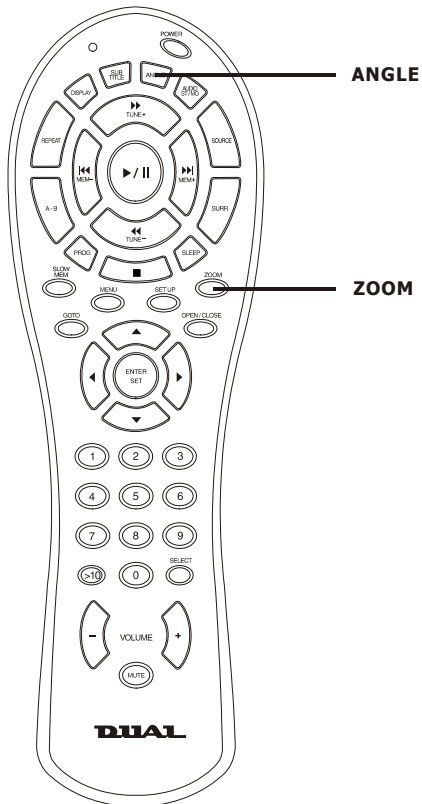

1. Press the **ZOOM** button repeatedly to select the following magnification factors: ZOOM X1.5 ⇒ ZOOM X2 ⇒ ZOOMX3 ⇒ OFF.

Notes :

- This function is only available during playback.
- This function is not available when playing CD or MP3 discs.
- This setting will be cancelled automatically when the disc tray is opened or the power is turned off.

Angle selection

Some DVD discs contain scenes which have been shot simultaneously from a number of different angles. For these discs, the same scenes can viewed from each of the different angles. (The recorded angles differ from disc to disc).

1. While playing a title shot from different angles, the angle logo appears on the TV screen. This feature can be turned off.
2. Press the **ANGLE** button to change the scenes from one angle to other angle(s).

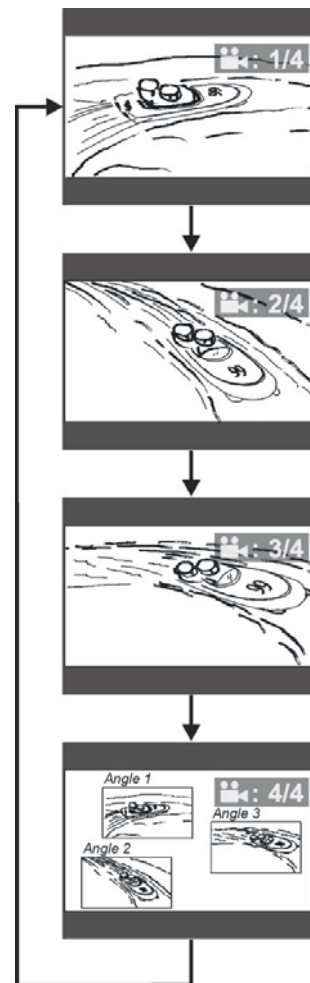

Special functions

Selecting the subtitle language

This function is available for DVD discs recorded with subtitles in multiple-languages.

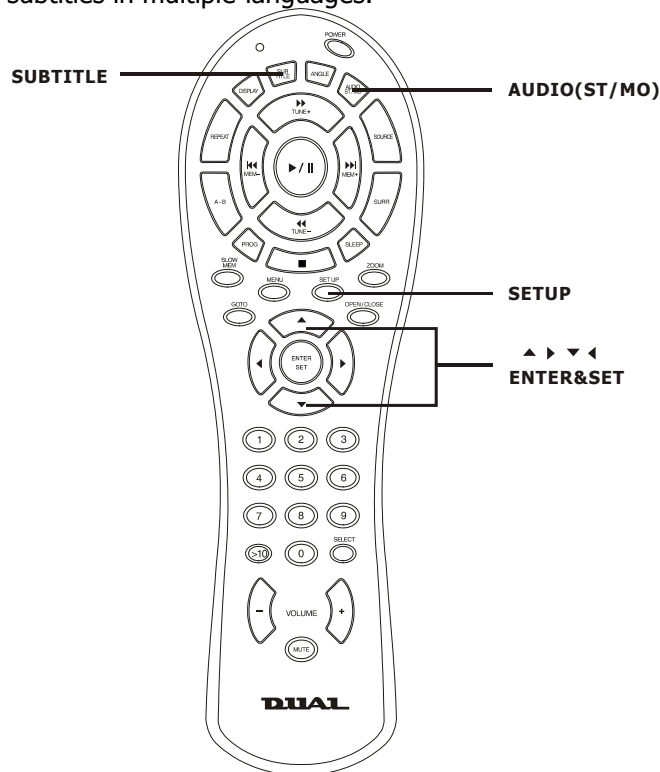

While playing DVD discs, press the **SUBTITLE** button once to display the current language selection. Continue pressing to select other subtitle languages. Press the **ENTER/SET** button and playback continues in the desired subtitle language.

Notes:

- Some DVD discs are recorded with subtitles that cannot be turned off.
- During some scenes, the subtitles may not appear immediately after you turn them on.
- Some DVD discs only allow you to change subtitle selections via the disc menu. Use the **◀/▶/▲/▼** buttons to select the desired language or turn the subtitles ON or OFF and then press the **ENTER/SET** button.
- The maximum number of subtitle languages stipulated by the manufacturer is 32.
- Use the setup menu to set a preferred language for subtitles.

Selecting the audio language

Dolby Digital, PCM, and other audio data can be recorded on DVD discs in a number of languages or audio tracks, allowing you to select the desired language.

While playing DVD discs, press the **AUDIO** button once to display the current language selection. Continue pressing to select other languages. Press the **ENTER/SET** button and playback continues in the desired language.

Notes:

- Some DVD discs only allow you to change audio selections via the disc menu. Use the **◀/▶/▲/▼** buttons to select the desired language and then press the **ENTER/SET** button.
- The maximum number of audio language stipulated by the manufacturer is 8.
- You can also set a preferred audio language using the setup menu.
- The unit will go to Dolby Prologic mode when playing a disc recorded in Dolby digital 2 CH signal to get better sound quality. The Dolby Digital icon will appear on the front panel display for 5 seconds.

Depending on the DVD disc, you may be able to change the audio format (including audio code type, number of channels recorded and audio language) using the AUDIO button. The relevant message appears on the TV display as shown below.

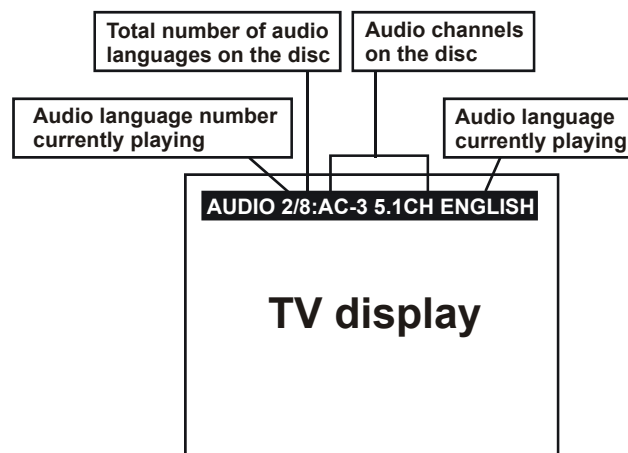

Setting the audio mode for karaoke music

When playing karaoke or similarly formatted DVD discs, it is possible to select vocal audio, or either right or left channel depending on the disc.

Press the **AUDIO** button repeatedly during playback to switch the audio output mode as follows: AUDIO 1 ⇨ AUDIO 2 ⇨ AUDIO 1 VOCAL ⇨ AUDIO 2 VOCAL.

When playing karaoke or similarly formatted VCD discs, it is possible to select stereo, or either right or level channel mono depending on the disc.

Press **AUDIO** button repeatedly during playback to switch to the audio output mode as follows: LEFT VOCAL ⇨ RIGHT VOCAL ⇨ MONO LEFT ⇨ MONO RIGHT ⇨ STEREO.

When playing karaoke or similarly formatted CD discs, it is possible to select stereo, or either right or level channel mono depending on disc.

Press the **AUDIO** button repeatedly during playback to switch to the audio output mode as follows: MONO LEFT ⇨ MONO RIGHT ⇨ STEREO.

NOTE: This system does not support CD-G formatted discs.

Selecting the output signal (Progressive/Interlaced)

Some televisions or monitors are equipped with component video inputs that are capable of reproducing a progressively scanned video signal. Connecting to these inputs to 480p progressive-scan components allows you to view the highest quality pictures with high resolution.

NOTE: Your television or monitor must also be set to the 480p mode.

Setting the progressive-scan mode:

1. Press the **SOURCE** button to select DVD mode.
2. Press the **OPEN/CLOSE** button to open the DVD door.
3. Press **STOP** button five times, to select Progressive Scan ON or OFF.

Setting Pr/Pb/Y mode:

Using the setup menu (Press the **SETUP** button on the remote control), select the video output menu from general setup. Select the PrPbY mode.

Other functions

Operating the radio

The receiver has a built-in tuner that allows for AM/FM radio function.

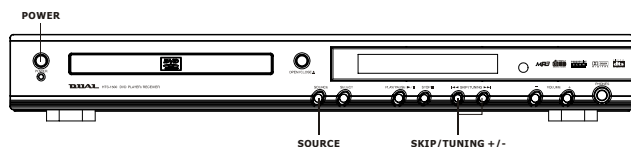

Manual tuning

1. Connect the FM and AM antenna accordingly (see "Connecting the Antenna" on page 12 section for details)
2. Press the **POWER** button to switch on the receiver.
3. Press the **SOURCE** button to enter TUNER mode.
4. To select band, press the **SOURCE** button to toggle between AM/FM modes.
5. Tune the stations by pressing the **◀TUNE** or **TUNE▶** buttons repeatedly until the desired station is found.

NOTE: To activate the automatic search function, press and hold the **◀TUNE** or **TUNE▶** buttons for about 2 seconds. In this mode the receiver will automatically tune frequencies until it finds a station.

Selecting Mono or Stereo Sound

Press the **AUDIO (ST/MONO)** button on the remote control to switch between mono and stereo sound in FM tuner mode (when available).

Note: After pressing the **◀TUNE** or **TUNE▶** , **◀MEM** or **MEM▶** buttons, the listening mode will automatically change to stereo.

Storing radio stations:

You can easily enter and store up to 40 AM or FM radio stations in the receiver's memory.

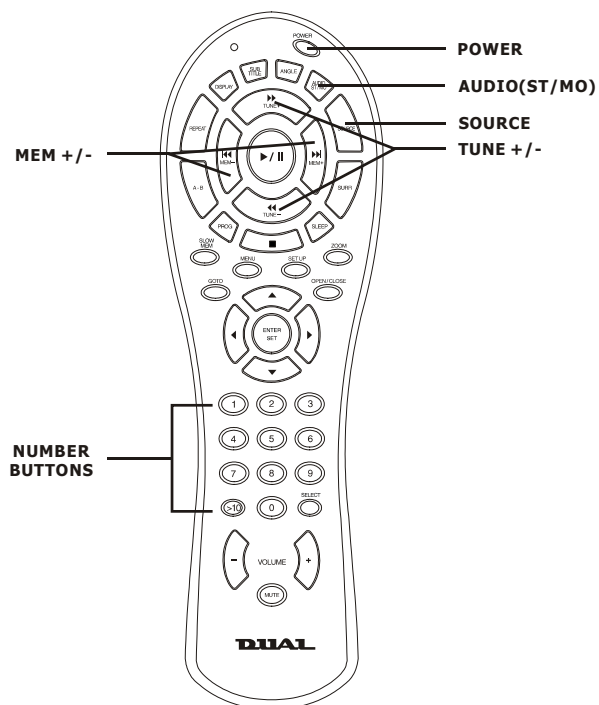

Manual preset

1. Select FM or AM band by pressing the **SOURCE** button repeatedly.
2. Tune to the radio station to be stored by pressing the **◀TUNE** or **TUNE▶** buttons on the remote control.
3. Press the **SLOW/MEMO** button on the remote control. "PROG" and the preset number will appear on the front panel display.
4. Press the **◀MEM**, **MEM▶**, or enter the number buttons (**0~9**, **>10**), while "PROG" is still flashing to select the desired preset memory location.
5. Press the **SLOW/MEMO** button on the remote control to store a frequency in the preset location.
6. Repeat steps 1-5 to store other frequencies.

Retrieving preset stations

1. Press the **SOURCE** button to select tuner mode.
2. Press the **◀MEM** or **MEM▶** buttons on the front panel or remote control to select preset stations.

Other functions

Listening to an external source

You can listen to other audio component(s) connected to this system through your new speaker system.

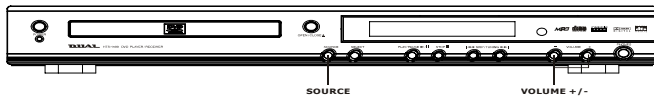

To operate the audio component which is connected to this system, press the **SOURCE** button repeatedly until "AUX" appears on the front panel display.

Adjust the volume level by pressing the **VOLUME +** or **VOLUME -** buttons.

Note: This system has a built in Dolby Pro Logic decoder, so you can enjoy the live sound in Dolby Surround with all speaks operating.

Using the sleep timer

Use this function to program the system to turn off automatically after a specified amount of time.

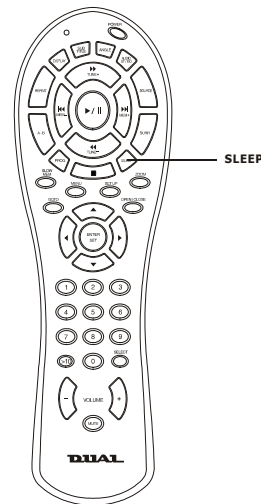

Press the **SLEEP** button repeatedly, to select the following the time intervals in minutes: 10 ⇨ 20 ⇨ 30 ⇨ 40 ⇨ 50 ⇨ 60 ⇨ 70 ⇨ 80 ⇨ 90 ⇨ 100 ⇨ 110 ⇨ 120 ⇨ 00 (off).

- When you have selected the specified time, the "SLEEP" indicator lights on the television screen and front panel display.
- To reset the time, press the **SLEEP** button again to make another selection.
- To check the remaining time before the system turns off, press the **SLEEP** button. The remaining time will be displayed on the television screen and front panel for a few seconds.
- To cancel the sleep function, press the **SLEEP** button until it reaches 00 (off).

Limited Warranty

What your warranty covers:

- Defects in materials or workmanship

For how long after your purchase:

- Two year from the date of purchase for labor and parts
- The warranty period for rental units begins with the first rental or 45 days from date of shipment to the rental firm, whichever comes first.

How you get service:

- Take your unit to any Authorized Service Center. To identify you're nearest Authorized Service Center, ask your dealer, look in the Yellow Pages, or call 1-800-336-1900.
- Show the Authorized Service Center Representative your evidence of purchase date or first rental.
- Pick up your unit when repairs are completed.
- Proof of purchase in the form of a bill of sale or receipted invoice that is evidence that the product is within the warranty period must be presented to obtain warranty service. For rental firms, proof of first rental is also required.

What your warranty does not cover:

- Customer instruction. (Your Owner's Manual describes how to install, adjust, and operate your unit. Any additional information should be obtained from your dealer.)
- Installation and related adjustments.
- Single reception problems not caused by your unit.
- Damage from misuse or neglect.
- Cleaning of audio heads.
- Batteries.
- A unit that has been modified or incorporated into other products or is used for institutional or other commercial purposes.
- A unit purchased or serviced outside the U.S.A.
- Acts of nature, such as but not limited to lightning damage.

Product Registration:

- Please complete and mail the Product Registration Card packed with your product. It will make it easier to contact you should it ever be necessary. The return of the card is not required for warranty coverage.

Limitation of Warranty:

- **THE WARRANTY STATED ABOVE IS THE ONLY WARRANTY APPLICABLE TO THIS PRODUCT. ALL OTHER WARRANTIES, EXPRESS OR IMPLIED (INCLUDING ALL IMPLIED WARRANTIES OF MERCHANTABILITY OR FITNESS FOR A PARTICULAR PURPOSE) ARE HEREBY DISCLAIMED. NO VERBAL OR WRITTEN INFORMATION GIVEN BY xxxxxxxxx. ITS AGENTS OR EMPLOYEES SHALL CREATE A WARRANTY OR IN ANY WAY INCREASE THE SCOPE OF THIS WARRANTY.**
- **REPAIR OR REPLACEMENT AS PROVIDED UNDER THIS WARRANTY IS THE EXCLUSIVE REMEDY OF THE CONSUMER. xxxxxxxxx SHALL NOT BE LIABLE FOR INCIDENTAL OR CONSEQUENTIAL DAMAGES RESULTING FROM THE USE OF THIS PRODUCT OR IMPLIED WARRANTY ON THIS PRODUCT. THIS DISCLAIMER OF WARRANTIES AND LIMITED WARRANTY ARE GOVERNED BY THE LAWS OF THE LAWS OF THE STATE OF INDIANA. EXCEPT TO THE EXTENT PROHIBITED BY APPLICABLE LAW, ANY IMPLIED WARRANTY OF MERCHANTABILITY OR FITNESS FOR A PARTICULAR PURPOSE ON THIS PRODUCT IS LIMITED TO THE APPLICABLE WARRANTY PERIOD SET FORTH ABOVE.**

How State Law relates to warranty:

- Some states do not allow the exclusion nor limitation of incidental or consequential damages, or limitations on how long an implied warranty lasts, so the above limitations or exclusions may not apply to you.
- This warranty gives you specific legal rights, and you also may have other rights that vary from state to state.

If you purchased your unit outside the United States:

- This warranty does not apply. Contact your dealer for warranty information.

Service calls which do not involve defective materials or workmanship are not covered by this warranty. Costs of such service calls are the sole responsibility of the purchaser.

Specifications

DVD Section

Laser type.....	Semiconductor laser, Wavelength 650 nm
Signal system.....	NTSC
Video Format.....	4 : 3 / 16 : 9
Video Output Level.....	1 Vp-p (75 ohm)
Video Y Output Level.....	1 Vp-p (75 ohm)
Video C Output Level.....	286m Vp-p (75 ohm)
Audio Frequency Response.....	4Hz - 22KHz (48KHz)
.....	4Hz - 44KHz (96KHz)

TUNER Section

Tuning Range.....	FM 87.9 - 107.9MHz (200KHz steps)
.....	AM 520 - 1710kHz (10KHz steps)
26dB quieting sensitivity.....	FM 20dB
.....	AM 3162 uV/m
Image rejection radio.....	FM 25dB
.....	AM 28dB
IF rejection radio.....	FM 60dB
.....	AM 24dB
Signal to Noise ratio.....	FM 60dB
.....	AM 40dB
AM suppression ration.....	FM 30dB
Harmonic distortion.....	FM mono 3%
.....	FM stereo 3%
.....	AM 5%
Frequency Response.....	FM 180Hz - 10KHz, ± 6dB
Stereo Separation.....	FM 26dB (1KHz)
Stereo threshold.....	FM 23.5dB

AMPLIFIER Section

Output Power - Stereo mode (DIN)	2 X 15W
- Surround mode (1KHz)	15W RMS/channel
Total harmonic distortion.....	10% at rated power

(1KHz)
 Frequency response.....180Hz – 14KHz, ± 1dB
 Signal to Noise ration..... > 65dB
 (CCIR)
 Input sensitivity.....400mV

GENERAL

Power Supply.....120V/50Hz
 Power consumption.....100W
 Dimension.....L430 X W347 X H52
 mm
 Weight.....5.2 Kg

SPEAKER

Front & Center

System.....1-way shielded
 Impedance.....8 ohm
 Speaker drivers.....3" full
 range
 Dimension.....W90 X H147 X D110
 mm
 Weight.....0.52Kg/each

Surround

System.....1-way no shielded
 Impedance.....8 ohm
 Speaker drivers.....3" full
 range
 Dimension.....W90 X H147 X D110
 mm
 Weight.....0.45Kg/each

SUBWOOFER

Subwoofer.....6 1/2"
 Output power.....30W
 Impedance.....4 ohm
 Dimension.....W199 X H307 X D320
 mm
 Weight.....5.0Kg